

**SE-703 MANUAL**  
**EARTH-LEAKAGE MONITOR**

**MARCH 4, 2008**

**REVISION 6**

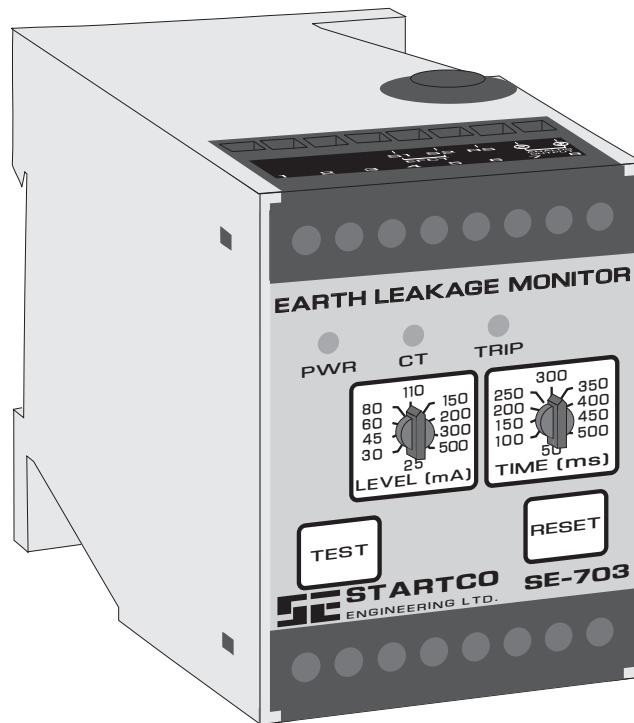

Copyright © 2008 by Startco Engineering Ltd.

All rights reserved.

This page intentionally left blank.



## TABLE OF CONTENTS

	<b>PAGE</b>
Table of Contents .....	i
List of Figures.....	i
List of Tables.....	i
<b>1. General</b> .....	<b>1</b>
<b>2. Operation</b> .....	<b>1</b>
2.1 Configuration-Switch Settings .....	1
2.1.1 Relay Operating Mode.....	1
2.1.2 Filter Selection.....	1
2.2 Front-Panel Controls.....	1
2.2.1 Earth-Leakage Trip Level.....	1
2.2.2 Earth-Leakage Trip Time.....	1
2.2.3 Reset.....	1
2.2.4 Test.....	1
2.3 Front-Panel Indication.....	1
2.3.1 Power .....	1
2.3.2 Trip.....	1
2.3.3 CT Verification.....	1
2.4 Analog Output .....	3
2.5 Self Diagnostics.....	3
<b>3. Installation</b> .....	<b>3</b>
<b>4. SE-703 Compatibility</b> .....	<b>4</b>
<b>5. Technical Specifications</b> .....	<b>10</b>
<b>6. Ordering Information</b> .....	<b>11</b>
<b>7. Warranty</b> .....	<b>11</b>
<b>8. Performance Test</b> .....	<b>12</b>

## LIST OF FIGURES

<b>FIGURE</b>		<b>PAGE</b>
1.	SE-703 Outline and Mounting Details.....	2
2.	Typical Connection Diagram .....	3
3.	EFCT-1 Outline and Mounting Details .....	5
4.	EFCT-2 Outline and Mounting Details .....	6
5.	EFCT-26 Outline and Mounting Details .....	7
6.	PMA-55 Panel-Mount Adapter.....	8
7.	PMA-60 Panel-Mount Adapter.....	9
8.	Earth-Fault-Test Circuit.....	12

## LIST OF TABLES

<b>TABLE</b>		<b>PAGE</b>
1.	Trip-Feature Comparison .....	4
2.	Earth-Fault-Test Record .....	12

## DISCLAIMER

Specifications are subject to change without notice. Startco Engineering Ltd. is not liable for contingent or consequential damages, or for expenses sustained as a result of incorrect application, incorrect adjustment, or a malfunction.



This page intentionally left blank



## 1. GENERAL

The SE-703 is a microprocessor-based earth-leakage monitor for ac power supply systems incorporating earth-fault current limitation. Its output relay can operate in the fail-safe or non-fail-safe mode for undervoltage or shunt-trip applications. The SE-703 has one output relay with isolated normally open and normally closed contacts for use in independent control circuits. Additional features include LED trip and power indication, latching trips with front-panel and remote reset, trip memory, test switch, self diagnostics, 0 to 5-V analog output, CT verification with LED indication, digital selector switches, and switch-selectable algorithms for fixed-frequency or variable-frequency applications.

Earth-leakage current is sensed by an EFCT-series core-balance, earth-fault current transformer. The trip level of the earth-leakage circuit is digital-switch selectable from 25 to 500 mA. Trip time is digital-switch selectable from 50 to 500 ms.

The SE-703 is AS/NZS 2081:2002 compliant.

## 2. OPERATION

### 2.1 CONFIGURATION-SWITCH SETTINGS

See Fig. 1.

#### 2.1.1 RELAY OPERATING MODE

Switch 1 is used to set the operating mode of the output relay. In the fail-safe mode, the output relay energizes when the earth-leakage circuit is not tripped. In the non-fail-safe mode, non-volatile memory retains the trip status of the SE-703. If tripped, and the supply voltage is cycled, the SE-703 will remain tripped, with the trip relay de-energized and the TRIP LED on, until reset.

In the non-fail-safe mode, the output relay energizes when an earth-leakage trip occurs. In the non-fail-safe mode, trip status is not retained in non-volatile memory.

#### 2.1.2 FILTER SELECTION

Switch 2 is used to select the filtering algorithm for a fixed-frequency (50/60 Hz) or variable-frequency application. The FIXED FREQUENCY setting uses a DFT filter that allows lower trip levels to be used by rejecting harmonics that can cause nuisance tripping.

The VARIABLE FREQUENCY setting uses a peak-detection algorithm with a wider bandwidth for fault detection in variable-frequency drive applications.

## 2.2 FRONT-PANEL CONTROLS

### 2.2.1 EARTH-LEAKAGE TRIP LEVEL

The LEVEL (mA) selector switch is used to set the earth-leakage trip level. For earth-leakage detection, the earth-leakage trip level must be substantially below the prospective earth-fault current. To avoid sympathetic tripping, the trip level must be above the charging current of the protected feeder.

### 2.2.2 EARTH-LEAKAGE TRIP TIME

The SE-703 has a definite-time trip characteristic. The TIME (ms) selector switch is used to set the earth-leakage trip time for coordination with upstream and downstream earth-fault devices. Coordination requires the same trip level for all earth-leakage devices in a system and the trip time to progressively increase upstream. The amount of equipment removed from the system will be a minimum if the first earth-leakage device to operate is the one immediately upstream from the fault.

### 2.2.3 RESET

A trip remains latched until the RESET switch is pressed or the remote-reset terminals (6 and 7) are momentarily connected. In the non-fail-safe relay operating mode, cycling the supply voltage will also reset the SE-703.

The reset circuit responds only to a momentary closure so that a jammed or shorted switch will not prevent a trip. The front-panel RESET switch is inoperative when the remote-reset terminals are connected.

### 2.2.4 TEST

The TEST switch is used to test the earth-leakage circuit, the indication, and the output relay. When the TEST switch is pressed for one second, a test signal is applied to the earth-leakage-detection circuit, the circuit will trip, the TRIP LED will light, and the output relay will operate.

## 2.3 FRONT-PANEL INDICATION

### 2.3.1 POWER

The green LED labeled PWR indicates presence of supply voltage.

### 2.3.2 TRIP

The red LED labeled TRIP indicates a trip. A solid red LED indicates an earth-leakage trip and a flashing LED indicates a trip initiated by a CT fault. Two fast flashes of the TRIP LED indicate a diagnostic trip. See Section 2.5.

### 2.3.3 CT VERIFICATION

The green LED labeled CT indicates that an EFCT-series sensor is connected.

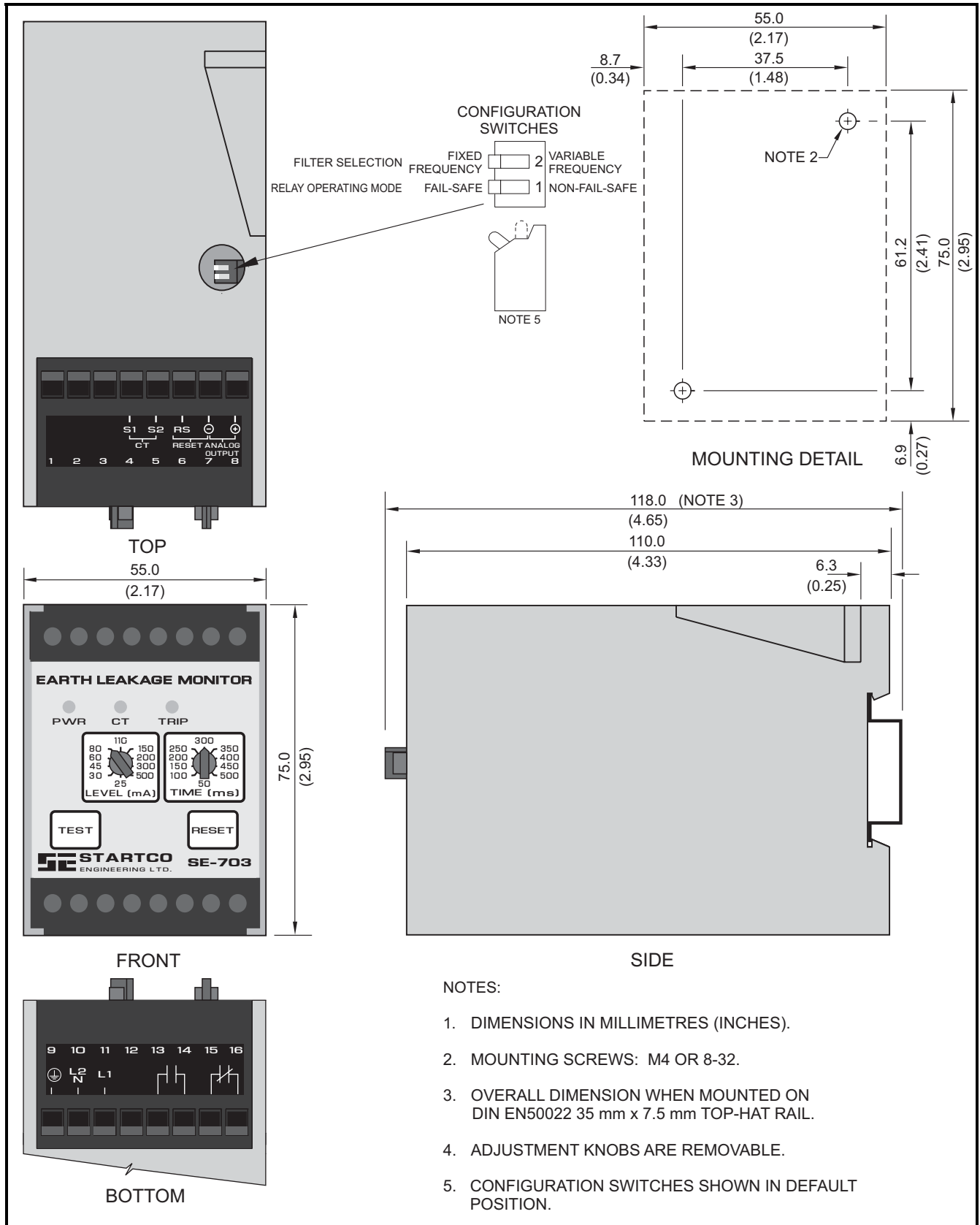

FIGURE 1. SE-703 Outline and Mounting Details.

## 2.4 ANALOG OUTPUT

The non-isolated, 0 to 5-V analog output indicates earth-leakage current sensed by the EFCT. The output is 5 V when earth-leakage current is 500 mA.

## 2.5 SELF DIAGNOSTICS

A diagnostic trip is indicated by two fast flashes of the TRIP LED. It can be caused by a problem detected by the watchdog timer, or by an incorrect reading from non-volatile memory. Press RESET or cycle supply voltage. If the problem persists, consult Startco.

## 3. INSTALLATION

This earth-leakage monitoring system consists of an SE-703 Earth-Leakage Monitor and an EFCT-series current sensor connected as shown in Fig. 2.

An SE-703 can be surface or DIN-rail mounted. See Fig. 1. Panel mounting requires a PMA-55 or PMA-60 Panel-Mount Adapter. See Figs. 6 and 7. A PMA-60 meets the AS/NZS 2081:2002 IP53 requirement.

Pass the phase conductors through the EFCT window and position them in the centre of the opening (for 4-wire and single-phase systems, also pass the neutral conductor through the EFCT window). Do not pass earth conductors through the EFCT window. In applications that require shields or drain wires to pass through the EFCT window, return them through the EFCT window before connecting them to earth. Connect the EFCT current sensor to terminals 4 and 5, connect the shield to terminal 5, and earth terminal 5. See Figs. 3, 4, and 5 for EFCT-series current-sensor dimensional drawings.

Remove the connection to terminal 9 for dielectric-strength testing.

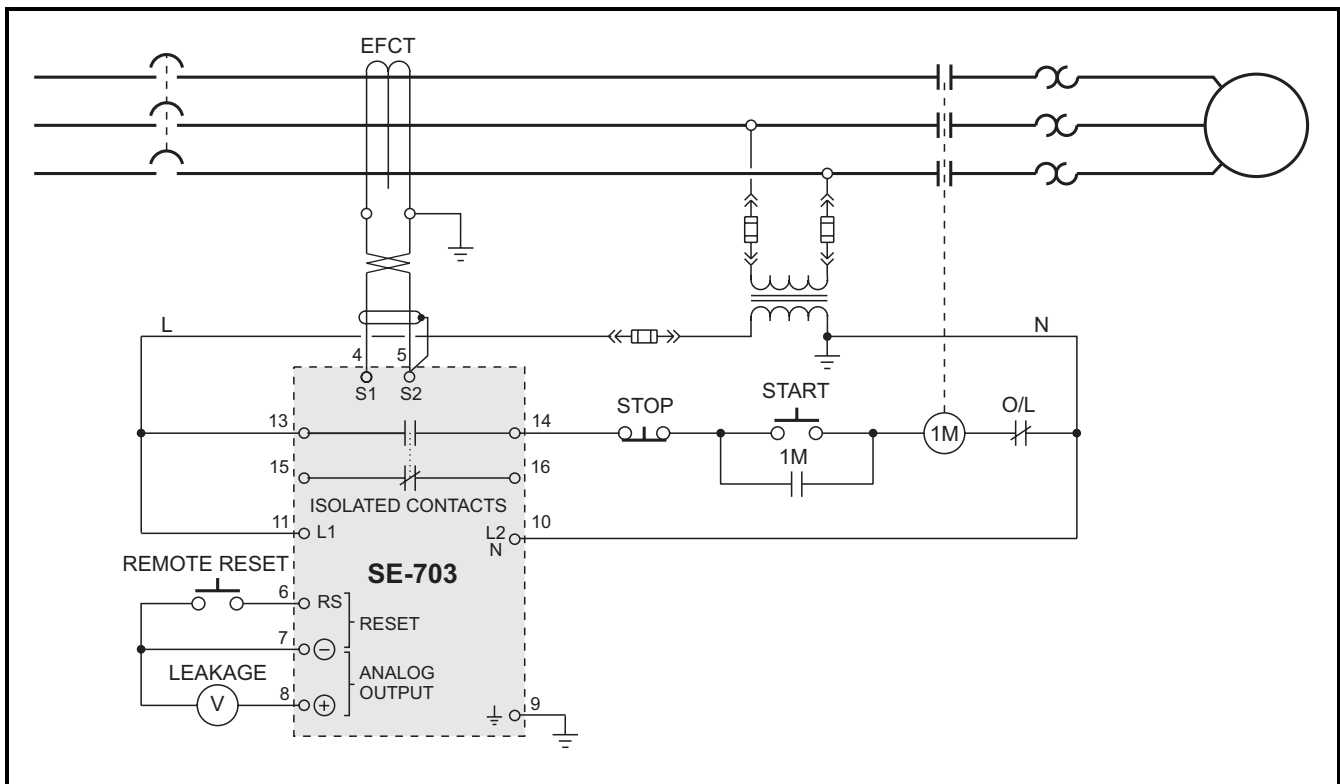

FIGURE 2. Typical Connection Diagram.



#### 4. SE-703 COMPATIBILITY

The current SE-703 has been enhanced with the addition of non-volatile trip memory for the fail-safe relay operating mode. Prior to hardware revision 04, a mechanical flag was used instead of non-volatile trip memory. The current revision of the SE-703 can directly replace previous revision units. The hardware-revision number is listed on the SE-703 model/serial-number label affixed to the SE-703 enclosure. Both generations of SE-703 are compared in Table 1.

The SE-703 was previously available with SE-703-01 120-Vac and SE-703-02 240-Vac control-voltage options. These have been discontinued. An SE-703-0U universal 120/240-Vac/Vdc unit can directly replace an SE-703-01 or SE-703-02.

TABLE 1. TRIP-FEATURE COMPARISON

		HARDWARE REVISION	
		00 - 03	≥ 04
LED trip indication		Yes	Yes
Mechanical flag trip indication		Yes	No
Non-volatile trip memory		No	Yes
Device state after supply voltage cycled when tripped (earth-fault removed)	Fail-safe	Trip LED: Off Trip relay: Energized Trip flag: Red	Trip LED: On Trip relay: De-energized
	Non-fail-safe	Trip LED: Off Trip relay: De-energized Trip flag: Red	Trip LED: Off Trip relay: De-energized

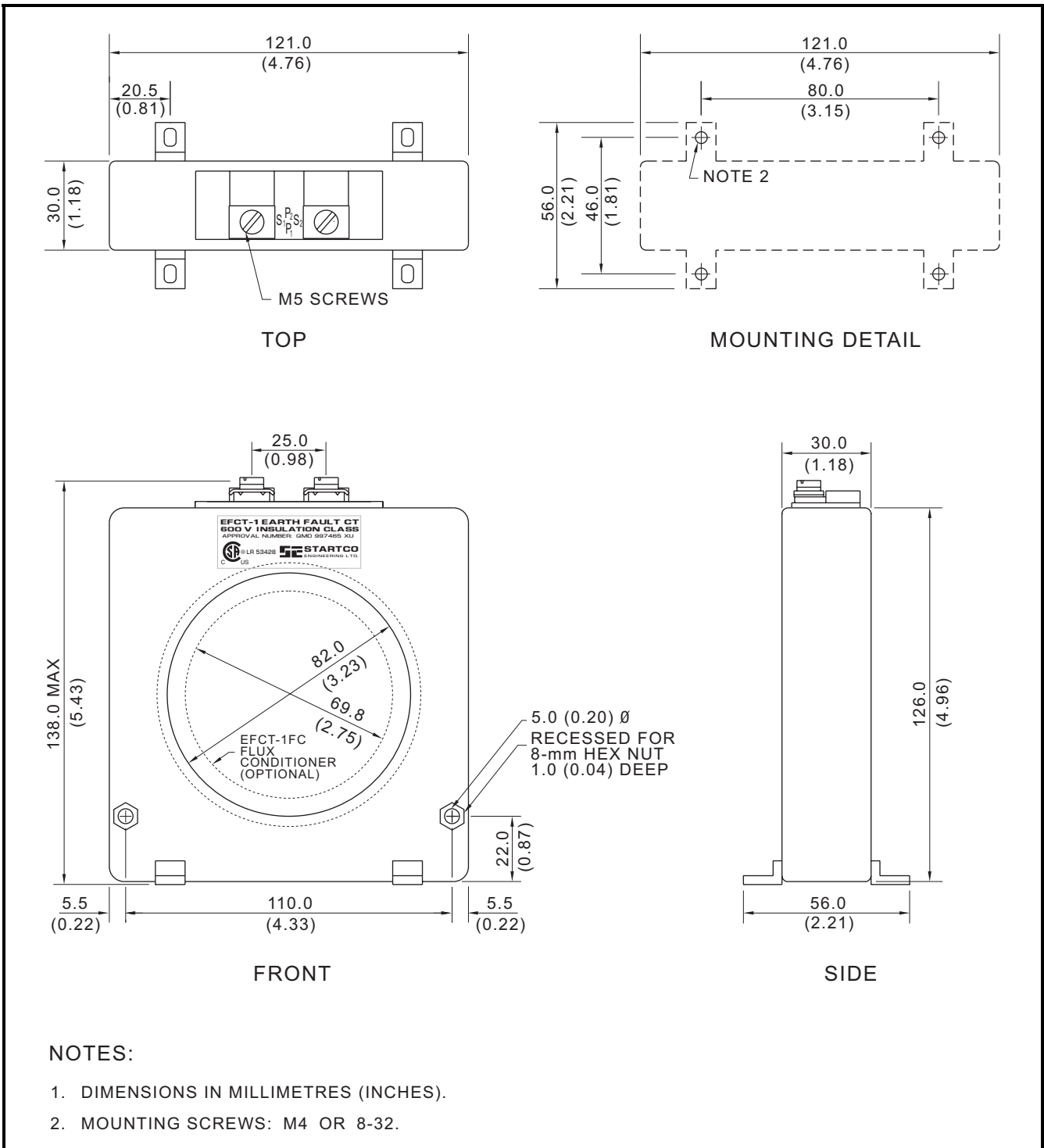

FIGURE 3. EFCT-1 Outline and Mounting Details.

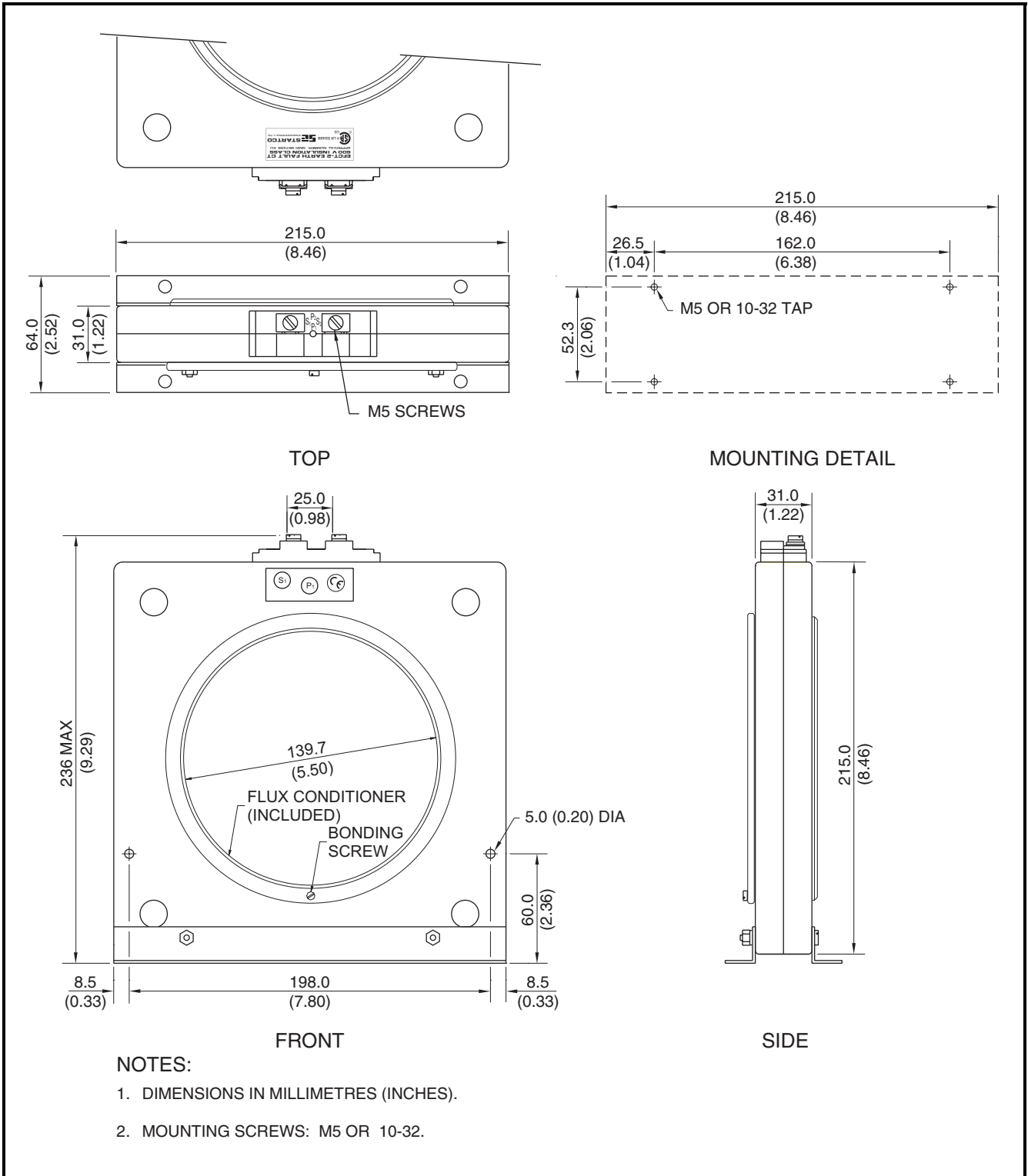

FIGURE 4. EFCT-2 Outline and Mounting Details.

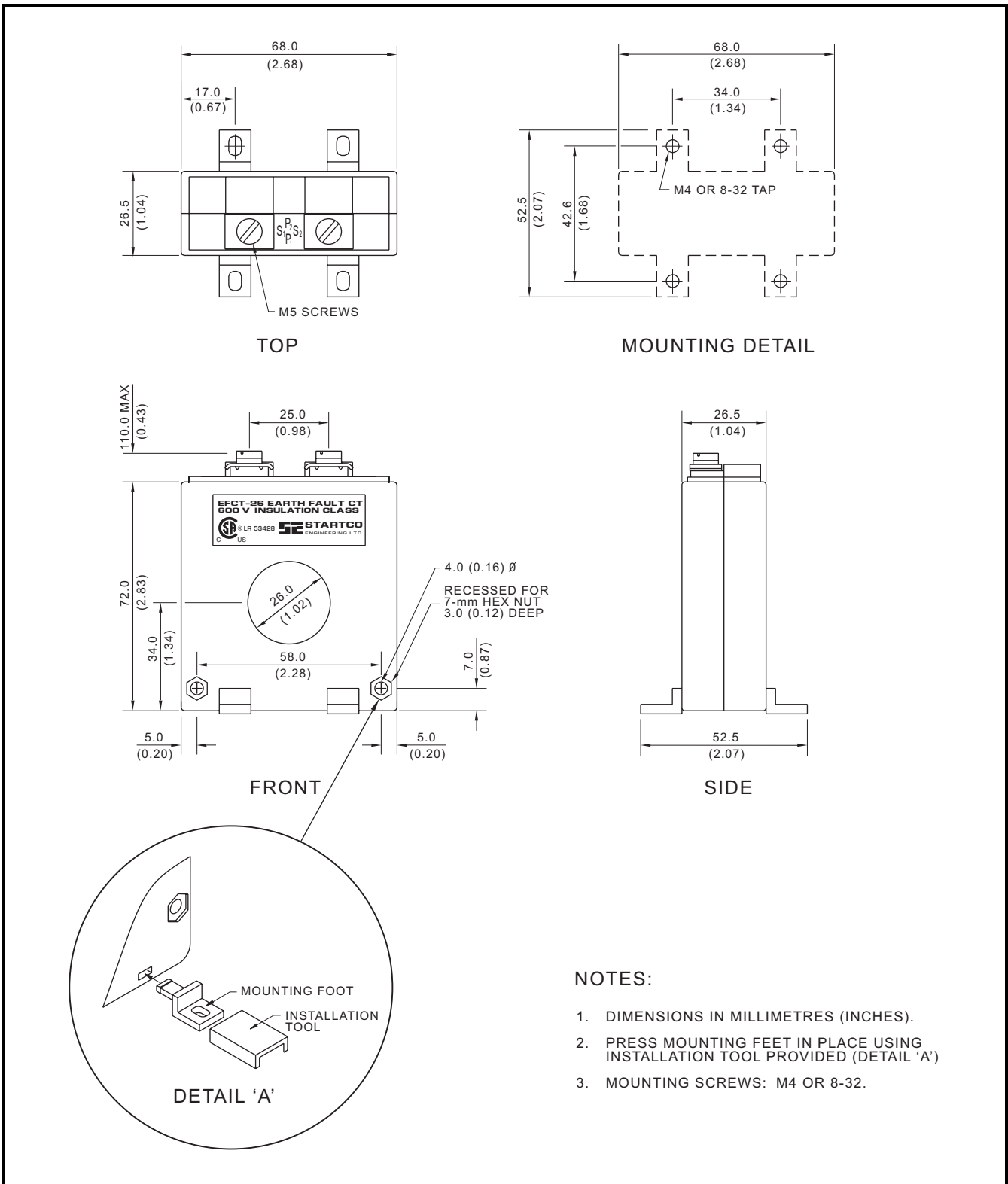

FIGURE 5. EFCT-26 Outline and Mounting Details.

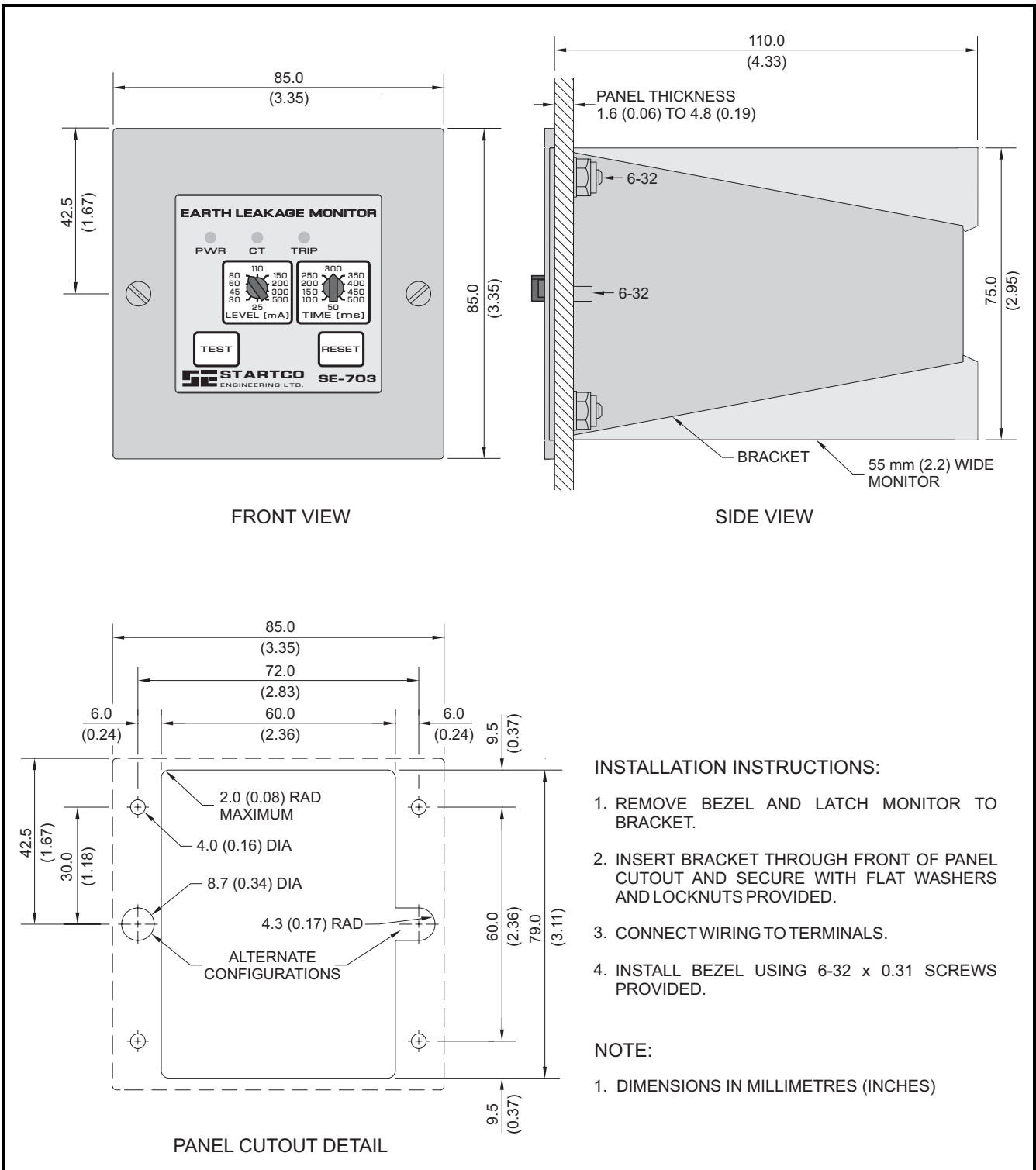

FIGURE 6. PMA-55 Panel-Mount Adapter

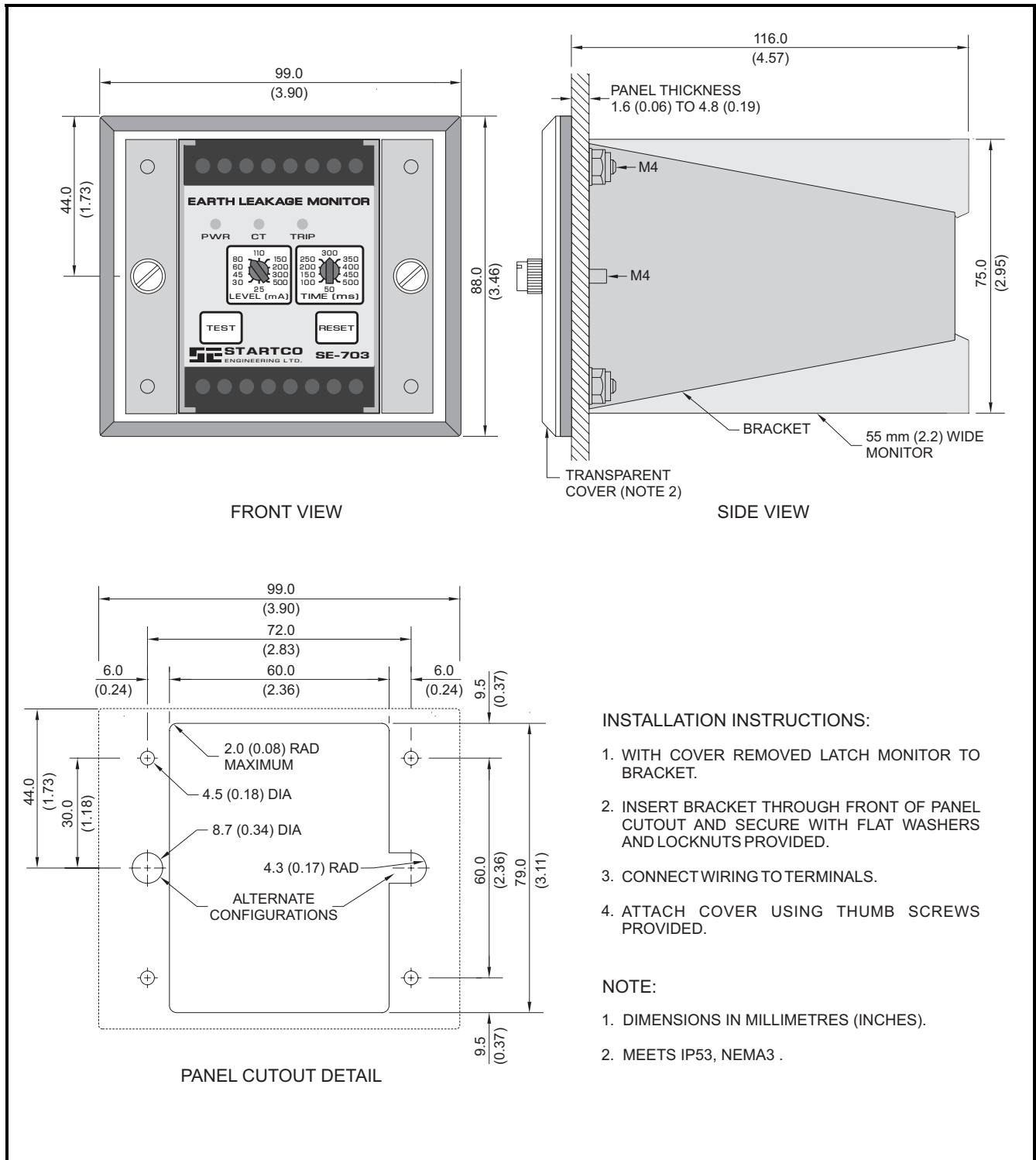

FIGURE 7. PMA-60 Panel-Mount Adapter



## 5. TECHNICAL SPECIFICATIONS

### Supply:

0U Option.....	2.5 VA, 120 to 240 Vac, (+20, -55%) 50/60 Hz, 2.0 W, 100 to 240 Vdc, (+20, -25%)
0D Option.....	2.0 W, 12 to 30 Vdc, (+20, -25%)
0T Option .....	2.0 W, 40 to 55 Vdc, (+20, -25%)
03 Option.....	2.5 VA, 24 Vac, (+15%, -40%), 50/60 Hz

Trip-Level Settings.....25, 30, 45, 60, 80, 110,  
150, 200, 300, and  
500 mA

Trip-Time Settings .....50, 100, 150, 200, 250,  
300, 350, 400, 450, and  
500 ms

### Accuracies: <sup>(1)</sup>

Trip Level <sup>(2)</sup> .....	+ 0, -20% of setting
Trip Time <sup>(3)</sup> .....	+0, -15 ms or +0, -20% of setting, whichever is larger

Discrimination Time <sup>(4)</sup> ..... ≥ 75% of trip time setting,  
Minimum off time 25 ms

### Input:

Algorithms .....	DFT Digital or Peak
DFT 3 dB Frequency Resp ..	32 to 86 Hz
Peak 3 dB Frequency Resp ..	20 to 420 Hz
CT.....	EFCT Series
Thermal Withstand:	
Continuous .....	25 A Earth-Fault Current
1-Second.....	400 A Earth-Fault Current

### Analog Output:

Range .....	0 to 5 V, 10 mV per mA
Output Impedance .....	220 Ω

Reset..... Front-Panel Switch and  
Remote, N.O. Contact

Functional Test ..... Front-Panel Switch

### Output Relay:

Contact Configuration .....	Isolated N.O. and N.C.
Operating Mode .....	Fail-Safe or Non-Fail-Safe
CSA/UL Rating .....	8 A Resistive, 250 Vac, 8 A Resistive, 30 Vdc

### Supplemental Contact Ratings:

Make/Carry 0.2 s .....	20 A
Carry Continuous .....	8 A

### Break:

dc.....	30 W Resistive, 15 W Inductive (L/R = 0.04)
ac.....	2,000 VA Resistive, 1,400 VA Inductive (PF = 0.4)

Subject to maximums of 8 A and 250 V (ac or dc).

Operating Mode..... Latching only

Terminals ..... Wire Clamping,  
0.2 to 2.5 mm<sup>2</sup> conductors  
(24 to 12 AWG)

### Dimensions:

Height .....	75 mm (3.0")
Width .....	55 mm (2.2")
Depth .....	115 mm (4.5")

Shipping Weight.....0.45 kg (1 lb.)

### Environment:

Operating Temperature.....	-40°C to 60°C
Storage Temperature.....	-55°C to 80°C
Humidity .....	85% Non-Condensing

Surge Withstand .....ANSI/IEEE 37.90.1-1989  
(Oscillatory and Fast  
Transient)

### EMC Tests:

Verification tested in accordance with EN 50263:2000	
Electrostatic Discharge.....	IEC 61000-4-2, EN 61000-4-2 6 kV Contact Discharge 8 kV Air Discharge

Radiated RF .....IEC 61000-4-3, EN 61000-4-3  
10 V/m, 80-1000 MHz,  
80% AM (1 kHz).  
10 V/m, 900 MHz,  
200 Hz Pulse Modulated

Fast Transient .....IEC 61000-4-4, EN 61000-4-4  
±2 kV Common Mode  
±1 kV Differential Mode



Surge Immunity.....	IEC 61000-4-5, EN 61000-4-5 ±2.0 kV Common Mode ±1.0 kV Differential Mode
Conducted RF .....	IEC 61000-4-6, EN 61000-4-6 10Vrms, 0.15-80 MHz, 80% AM (1 kHz)
Magnetic Field .....	IEC 61000-4-8, EN 61000-4-8 50 Hz, 30 A/m (continuous) 50 Hz, 300 A/m (1 to 3 seconds)
Pulsed Magnetic Field.....	IEC 61000-4-9, EN 61000-4-9 1000 A/m (Level 5)
Voltage Interruption .....	IEC 255-22-11, EN 60255-11 100% for 2, 5, 10, 20, 50, 100, & 200 ms
MHz Burst.....	IEC 255-22-1, EN 60255-22-1 1 kV Differential Mode 2.5 kV Common Mode
RFI Compliance .....	FCC Part 15, Subpart B, Class A – Unintentional Radiators
Compliance.....	AS/NZS 2081:2002
Certification .....	CSA (Canada and USA)



Australia



**NOTES:**

- (1) At 50 or 60 Hz.
- (2) Maximum lead resistance of 2 Ω.
- (3) Trip Time at 1.5 x trip-level setting.
- (4) Per AS/NZS 2081.3:2002 Clause 3.3.8.

**6. ORDERING INFORMATION**

SE-703-0	<input type="checkbox"/>	
	<input type="checkbox"/>	U Universal 120/240-Vac/Vdc Supply
	<input type="checkbox"/>	D 12/24-Vdc Supply
	<input type="checkbox"/>	T 48-Vdc Supply
	<input type="checkbox"/>	3 24-Vac Supply

EFCT-1 .....	Earth-Fault Current Transformer, 82-mm (3.2”) window
EFCT-2 .....	Earth-Fault Current Transformer, with Flux Conditioner 139-mm (5.5”) window
EFCT-26 .....	Earth-Fault Current Transformer, 26-mm (1.0”) window
EFCT-1FC .....	Flux Conditioner, 70 mm (2.7”) Window
PMA-55 .....	Panel-Mount Adapter, NEMA 1
PMA-60 .....	Panel-Mount Adapter, NEMA 3, IP53
PMA-3.....	Adapter Plate, GEC/MCGG
PMA-6.....	Adapter Plate, FPL-GFRM
PMA-15 .....	Adapter Plate, MGFR

Consult factory for custom mounting adapters.

**Startco Pty. Australian Current Transformers**

EFCT-5RF ...	Earth-Fault Current Transformer, 60-mm (2.4”) window
EFCT-8RF ...	Earth-Fault Current Transformer, 140-mm (5.5”) window
EFCT-9RF ...	Earth-Fault Current Transformer, 160-mm (6.3”) window
EFCT-10RF ..	Earth-Fault Current Transformer, 200-mm (7.9”) window

For additional information and to order contact:  
sales@startco.com.au.

**7. WARRANTY**

The SE-703 Earth-Fault Monitor is warranted to be free from defects in material and workmanship for a period of five years from the date of purchase.

Startco Engineering Ltd. will (at Startco’s option) repair, replace, or refund the original purchase price of an SE-703 that is determined by Startco to be defective if it is returned to the Startco factory, freight prepaid, within the warranty period. This warranty does not apply to repairs required as a result of misuse, negligence, an accident, improper installation, tampering, or insufficient care. Startco Engineering Ltd. does not warrant products repaired or modified by non-Startco Engineering Ltd. personnel.

