

Step 1

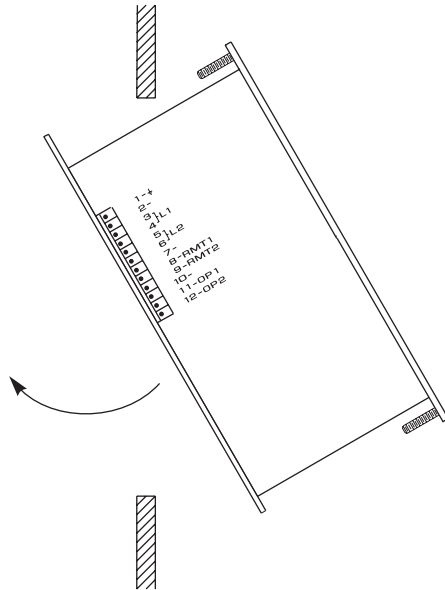

SE-400 PANEL-MOUNT INSTALLATION

The SE-400 may be panel mounted without disassembly.

NOTE: Remove plug-in terminal block before installing SE-400 through panel.

Step 2

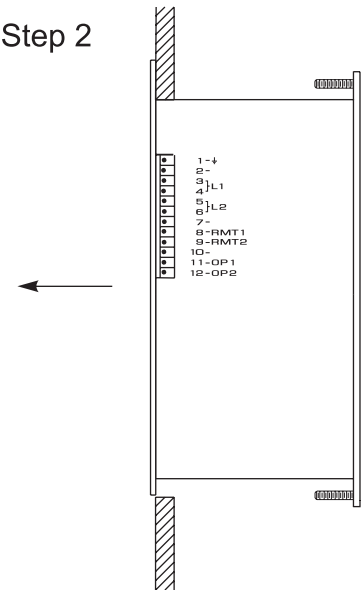

Step 3

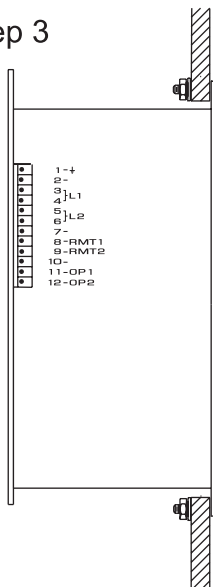

See reverse for outline and mounting details.

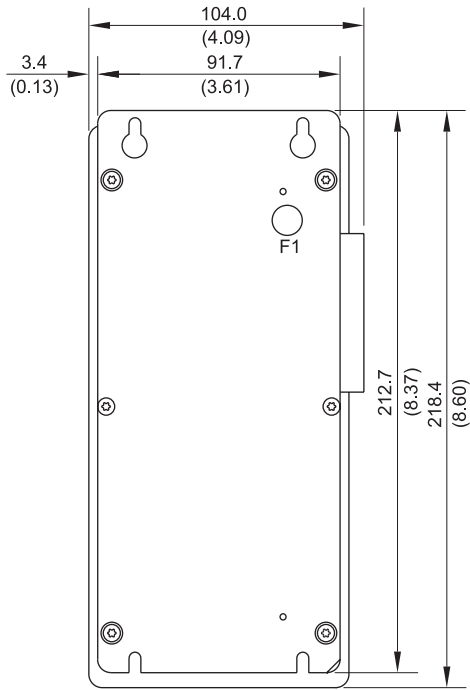

REAR VIEW

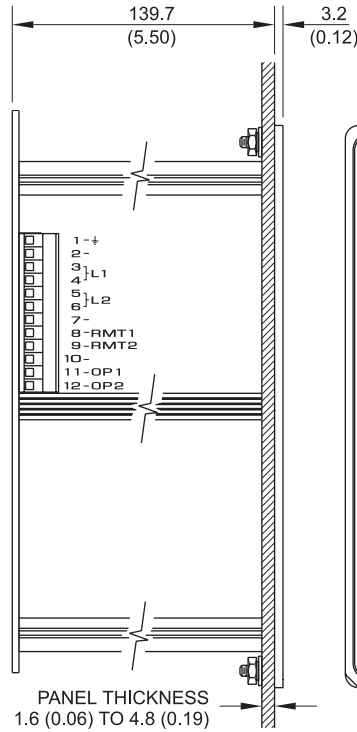

SIDE VIEW

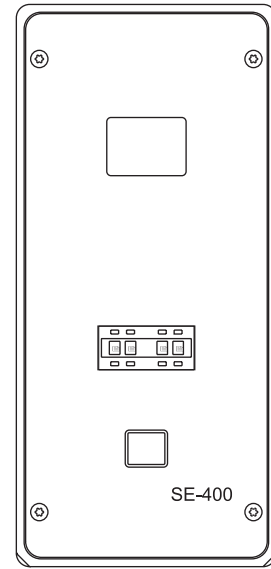

FRONT VIEW

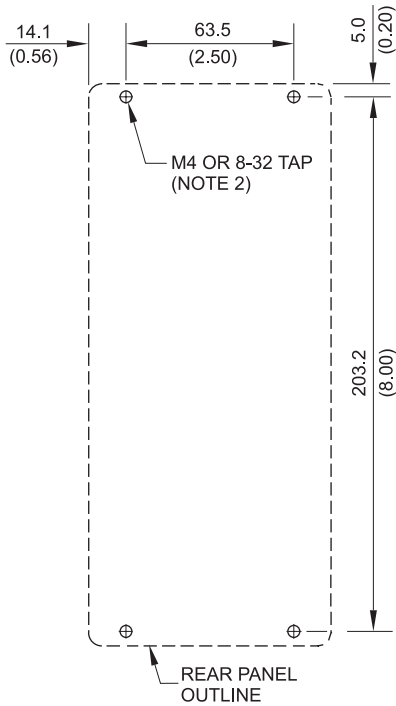

SURFACE MOUNT

NOTES:

1. DIMENSIONS IN MILLIMETRES (INCHES).
2. MOUNTING SCREWS: M4 x 10 OR 8-32 x 0.375.

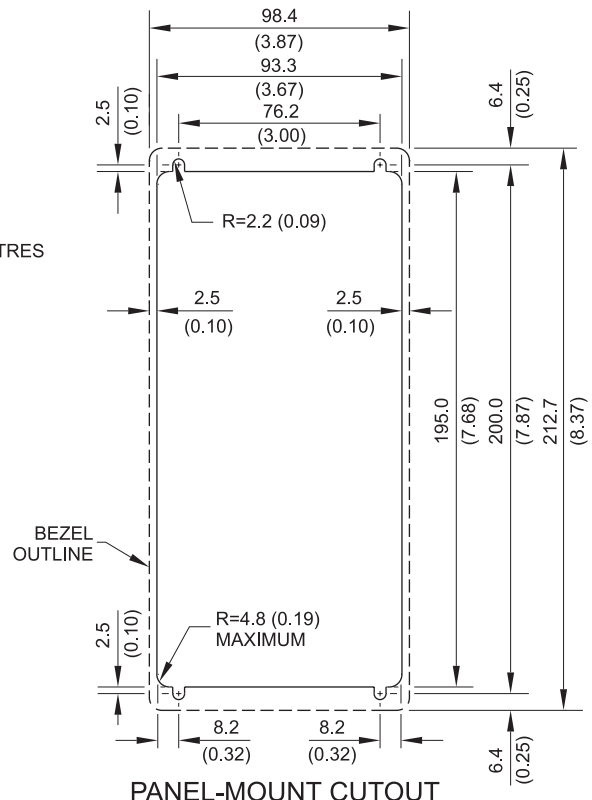

PANEL-MOUNT CUTOUT

SE-400 OUTLINE AND MOUNTING DETAILS