

**SE-330 MANUAL**  
**NEUTRAL-GROUNDING-RESISTOR MONITOR**

MARCH 11, 2008

REVISION 5

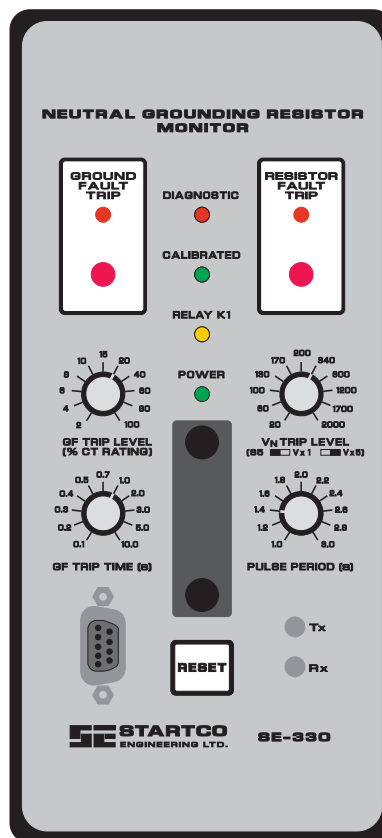

Copyright © 2008 Startco Engineering Ltd.

All rights reserved.

Blank Page



## TABLE OF CONTENTS

	PAGE
Table of Contents .....	i
List of Figures .....	i
List of Tables.....	i
<b>1. General</b> .....	<b>1</b>
1.1 Modern Resistance-Grounded Systems .....	1
1.2 SE-330 NGR Monitoring.....	1
<b>2. Operation</b> .....	<b>2</b>
2.1 Settings .....	2
2.1.1 GF Trip Time.....	2
2.1.2 GF Trip Level.....	2
2.1.3 V <sub>N</sub> Trip Level .....	2
2.1.4 Pulse-Period Adjustment .....	3
2.1.5 Configuration Settings.....	3
2.1.5.1 Relay K1 Function (S1).....	3
2.1.5.2 Trip-Relay Mode (S2).....	3
2.1.5.3 Ground-Fault-Trip Latch (S3).....	3
2.1.5.4 Resistor-Fault-Trip Latch (S4).....	3
2.1.5.5 Sensing-Resistor Selection (S5).....	3
2.1.5.6 Frequency (S6).....	4
2.1.5.7 Spare (S7) .....	4
2.1.5.8 Upgrade Enable (S8).....	4
2.2 Calibration .....	4
2.3 Pulsing Operation .....	4
2.4 Trip Indication and Reset.....	4
2.5 Remote Operation.....	4
2.6 Relay K1 LED .....	4
2.7 Unit Healthy Output .....	5
2.8 Diagnostic LED .....	5
2.9 Analog Output .....	5
<b>3. Installation</b> .....	<b>5</b>
3.1 SE-330 .....	5
3.2 Sensing Resistor.....	9
3.3 Ground-Fault CT .....	14
3.4 Isolated Ground Connection .....	17
3.5 Pulsing Connection.....	18
<b>4. Communications</b> .....	<b>18</b>
4.1 Local Communication Ports .....	18
4.1.1 Local Data Acquisition .....	18
4.1.2 Firmware Upgrade.....	18
4.2 Network Communications .....	18
<b>5. Troubleshooting</b> .....	<b>19</b>
<b>6. Technical Specifications</b> .....	<b>20</b>
6.1 SE-330 .....	20
6.2 Sensing Resistors.....	21
6.3 Current Sensors.....	21
<b>7. Ordering Information</b> .....	<b>22</b>

	PAGE
<b>8. Warranty</b> .....	<b>22</b>
<b>9. Test Procedures</b> .....	<b>22</b>
9.1 Resistor-Fault Tests .....	22
9.1.1 Calibration and Open Test.....	22
9.1.2 Voltage Test .....	23
9.2 Sensing-Resistor Test.....	23
9.3 Analog-Output Test.....	23
9.4 Ground-Fault Performance Test .....	23

## LIST OF FIGURES

FIGURE		PAGE
1	Configuration Switches .....	3
2	Analog-Output Connections.....	5
3	SE-330 Connection Diagram.....	6
4	SE-330 Outline and Panel-Mounting Details .....	7
5	SE-330 Outline and Surface-Mounting Details .....	8
6	ER-600VC Sensing Resistor .....	9
7	ER-5KV Sensing Resistor .....	10
8	ER-15KV Sensing Resistor .....	11
9	ER-25KV Sensing Resistor .....	12
10	ER-35KV Sensing Resistor .....	13
11	EFCT-1 Sensitive Ground-Fault Current Sensor .....	14
12	SE-CS30-70 Sensitive Ground-Fault Current Sensor .....	15
13	EFCT-26 and SE-CS30-26 Sensitive Ground-Fault Current Sensors .....	16
14	RK-332 Remote Indication and Reset .....	17
15	Simplified Isolated-Ground Connection.....	17
16	Simplified Pulsing Connection.....	18
17	Ground-Fault-Test Circuits .....	24

## LIST OF TABLES

TABLE		PAGE
1	Typical Values for Tripping Systems .....	2
2	Ground-Fault Trip Levels for Selected CT's.....	3
3	RS-232 DB-9 Terminals.....	18
4	Gound-Fault-Test Record.....	24

## DISCLAIMER

Specifications are subject to change without notice. Startco Engineering Ltd. is not liable for contingent or consequential damages, or for expenses sustained as a result of incorrect application, incorrect adjustment, or a malfunction.

Blank Page



## 1. GENERAL

### 1.1 MODERN RESISTANCE-GROUNDED SYSTEMS

A high-resistance-grounded system uses a neutral-grounding resistor (NGR) with a low let-through current to limit ground-fault current. High-resistance grounding is gaining popularity because a ground-fault flash hazard exists in low-resistance- or solidly grounded systems and a ground-fault can result in substantial point-of-fault damage. High-resistance grounding eliminates these problems and modern ground-fault protection operates reliably at these levels. Furthermore, the probability of an arc-flash incident is significantly reduced in a high-resistance-grounded system.

NGR selection depends on system charging current and whether the system is an alarm-only or a tripping system. Alarm-only systems are usually restricted to system voltages up to 5 kV with NGR let-through currents of 5 A or less. Occasionally, alarm-only systems up to 15 kV and up to 10 A are used; however, they are not common because a ground fault on such a system tends to escalate to a phase-to-phase fault before the ground fault can be located and cleared.

System charging current is the capacitive current that flows to ground when a bolted ground fault occurs. This current can be calculated or measured. For small systems, the magnitude of charging current is typically  $\frac{1}{2}$  A per 1,000 kVA on low-voltage systems and 1 A per 1,000 kVA on medium-voltage systems.

In an alarm-only system or in a tripping system without selective coordination, choose an NGR with a let-through current larger than the system charging current and set the pick-up current of ground-fault devices at or below 50% of the NGR let-through current.

In a tripping system with selective coordination, use ground-fault devices with a definite-time characteristic to achieve time coordination. Use the same pick-up current for all ground-fault devices—this value must be larger than the charging current of the largest feeder. Select an NGR with a let-through current between five and ten times the pick-up current of the ground-fault devices.

Do not use a grounding transformer with a low-voltage resistor:

- The combined cost of a transformer and a low-voltage resistor is more than the cost of a resistor rated for line-to-neutral voltage.
- A transformer saturated by a ground fault through a rectifier can make ground-fault protection inoperative.
- Transformer inrush current up to twelve times rated current can cause a ground-fault voltage larger than expected.
- A parallel transformer winding makes it difficult to monitor NGR continuity.
- A transformer can provide the inductance necessary to cause ferroresonance if the NGR opens.

Following these guidelines will reduce the flash hazard, reduce point-of-fault damage, achieve reliable ground-fault protection, and ensure a stable system not subject to ferroresonance.

### 1.2 SE-330 NGR MONITORING

The SE-330 is a microprocessor-based neutral-grounding-resistor monitor that detects NGR failures and ground faults in resistance-grounded systems. The SE-330 measures NGR resistance, NGR current, and transformer or generator neutral-to-ground voltage. The components required to monitor an NGR are an SE-330, an ER-series sensing resistor, and a current transformer (CT).

The SE-330 continuously measures NGR resistance in an unfaulted system, and it will trip on resistor fault if NGR resistance varies from its calibrated value. When a ground fault occurs, voltage is present on the neutral and NGR current will flow if the NGR is healthy. The SE-330 will trip on ground fault if fault current exceeds the GF TRIP LEVEL setting for an interval greater than the GF TRIP TIME setting. However, if the NGR fails open during a ground fault, it is possible for fault resistance to satisfy the NGR resistance measurement. To detect this double-fault condition, the SE-330 measures neutral voltage. If neutral voltage exceeds the  $V_N$  TRIP LEVEL setting, and if NGR current is less than 5% of the CT rating, the SE-330 will trip on resistor fault. If the resistor-fault circuit is tripped and the neutral voltage exceeds the  $V_N$  TRIP LEVEL setting for an interval greater than the GF TRIP TIME setting, the ground-fault circuit will also trip.

Ground-fault current is sensed by a CT with a 1- or 5-A secondary, or by a sensitive CT (EFCT-x or SE-CS30-x) with a 50-mA secondary. The trip level of the ground-fault circuit is adjustable from 2 to 100% of the CT rating and trip time is adjustable from 0.1 to 10.0 seconds.

The SE-330 has four output relays. Relay K1 can be assigned a trip or a pulsing function. Relays K2 and K3 provide ground-fault and resistor-fault indication. K4 is a solid-state relay that provides UNIT HEALTHY indication. When relay K1 is assigned the trip function, it can operate in the fail-safe or non-fail-safe mode for undervoltage or shunt-trip applications. When the pulsing function is selected, relay K1 is used to control a contactor to assist in fault location.

Additional features include LED and fluorescent-flag trip indication, trip memory, front-panel and remote reset, 4–20-mA analog output, RS-232 local communications, optical local communications, and optional network communications.



The SE-330 provides new features and improved performance over the SE-325 NGR Monitor:

- SE-330 dc rejection is sufficient for reliable operation in overhead-line applications.
- Digital filtering of voltage and current signals minimizes false trips due to harmonics.
- Resistance measurement is calibrated to the NGR to achieve a lower trip resistance.
- Broader setting ranges.
- Independent ground-fault and resistor-fault relays can be used for indication and control.
- Universal power supply.
- Wider CT-selection range.
- Network communications options provide information to a distributed control system.
- 4–20 mA analog output.
- UNIT HEALTHY output contact.
- Trip flags retain trip indication on power-supply loss.
- Pulsing capability can be used on low- and medium-voltage systems to assist in locating ground faults.
- RS-232 and optical local communication ports are provided for firmware upgrades and access to SE-330 measured parameters.

## 2. OPERATION

### 2.1 SETTINGS

#### 2.1.1 GF TRIP TIME

GF TRIP TIME (definite time) is adjustable from 0.1 to 10.0 seconds. Time-coordinated ground-fault protection requires this setting to be longer than the trip times of downstream ground-fault devices.

#### 2.1.2 GF TRIP LEVEL

The SE-330 uses a Discrete-Fourier Transform (DFT) algorithm to measure the fundamental component of NGR current.

Choose an NGR let-through current and a ground-fault trip level according to the guidelines in Section 1.1. Set the ground-fault trip level as a percentage (2, 4, 6, 8, 10, 15, 20, 40, 60, 80, or 100) of the CT-primary rating. Inputs are provided for 5-, 1-, and 0.05-A-secondary CT's. Typical values for 5-, 15-, and 25-A tripping systems are shown in Table 1. Ground-fault trip levels for selected CT's are shown in Table 2. For other systems, refer to the NGR Monitor Set-Point Assistant at [www.startco.ca](http://www.startco.ca).

#### 2.1.3 V<sub>N</sub> TRIP LEVEL

The SE-330 uses a DFT algorithm to measure the fundamental component of neutral voltage.

Calculate the voltage across the NGR when NGR current is equal to the pick-up current of the ground-fault circuit. Set the V<sub>N</sub> TRIP LEVEL at the next largest value. The V<sub>N</sub> TRIP LEVEL range is 20 to 2,000 V with switch S5 in the 20-kΩ (Vx1) position, and the range is 100 to 10,000 V with switch S5 in the 100-kΩ (Vx5) position. See Fig. 1 and Section 2.1.5.5.

If neutral voltage is greater than the V<sub>N</sub> TRIP LEVEL setting for 12 seconds and ground-fault current is less than 5% of the CT rating, the SE-330 will trip on resistor fault. If the resistor-fault circuit is tripped and the neutral voltage exceeds the V<sub>N</sub> TRIP LEVEL setting for an interval greater than the GF TRIP TIME setting, the ground-fault circuit will also trip.

Typical values for 5-, 15-, and 25-A tripping systems are shown in Table 1. For an NGR resistance greater than 2 kΩ, use a 100-kΩ sensing resistor. For other systems, refer to the NGR Monitor Set-Point Assistant at [www.startco.ca](http://www.startco.ca).

**NOTE:** A resistor-fault trip is held off if the ground-fault current is above 5% of the CT rating.

TABLE 1. TYPICAL VALUES FOR TRIPPING SYSTEMS

System Voltage (Volts)	Neutral-Grounding Resistor		Sensing Resistor		Ground-Fault Trip Level (Amperes)	V <sub>N</sub> Trip Level (Volts)
	Current (Amperes)	Resistance (Ohms)	Model	Resistance (Switch S5 Setting)		
480	5	55	ER-600VC	20 kΩ	1.0	60
600	5	69	ER-600VC	20 kΩ	1.0	100
2,400	5	277	ER-5KV	20 kΩ	1.0	340
4,160	5	480	ER-5KV	20 kΩ	1.0	800
480	15	18	ER-600VC	20 kΩ	3.0	60
600	15	23	ER-600VC	20 kΩ	3.0	100
2,400	15	92	ER-5KV	20 kΩ	3.0	340
4,160	15	160	ER-5KV	20 kΩ	3.0	800
7,200	15	277	ER-15KV	100 kΩ	3.0	170x5=850
14,400	15	554	ER-15KV	100 kΩ	3.0	340x5=1,700
4,160	25	96	ER-5KV	20 kΩ	5.0	800
7,200	25	166	ER-15KV	100 kΩ	5.0	170x5=850
14,400	25	332	ER-15KV	100 kΩ	5.0	340x5=1,700
25,000	25	577	ER-25KV	100 kΩ	5.0	800x5=4,000
35,000	25	808	ER-35KV	100 kΩ	5.0	1,200x5=6,000



TABLE 2. GROUND-FAULT TRIP LEVELS FOR SELECTED CT'S

GF TRIP LEVEL (%)	EFCT-x 5:0.05 (Amperes)	SE-CS30-x 30:0.05 (Amperes)	50:1 50:5 (Amperes)	100:1 100:5 (Amperes)	200:1 200:5 (Amperes)	400:1 400:5 (Amperes)
2	0.10	0.60	*	*	*	*
4	0.20	1.20	*	*	*	16
6	0.30	1.80	*	*	12	24
8	0.40	2.40	*	8	16	36
10	0.50	3.00	5	10	20	40
15	0.75	4.50	7.5	15	30	60
20	1.00	6.00	10	20	40	80
40	2.00	12.0	20	40	80	160
60	3.00	18.0	30	60	120	240
80	4.00	24.0	40	80	160	320
100	5.00	30.0	50	100	200	400

\* Setting not recommended.

### 2.1.4 PULSE-PERIOD ADJUSTMENT

Pulse period is the cycle time of relay K1 when the SE-330 is configured for pulsing operation. Pulse period is adjustable from 1.0 to 3.0 seconds with a fixed duty cycle of 50%. For example, with the 1.0-s setting, relay K1 will alternately be energized for 0.5 seconds and de-energized for 0.5 seconds when pulsing is enabled.

**NOTE:** For pulsing configuration, set switch S1 to K1 = PULSING and install an external pulse-enable switch.

### 2.1.5 CONFIGURATION SETTINGS

Eight configuration switches (S1 to S8) and a calibration push button are located behind the access cover on the front panel. See Fig. 1.

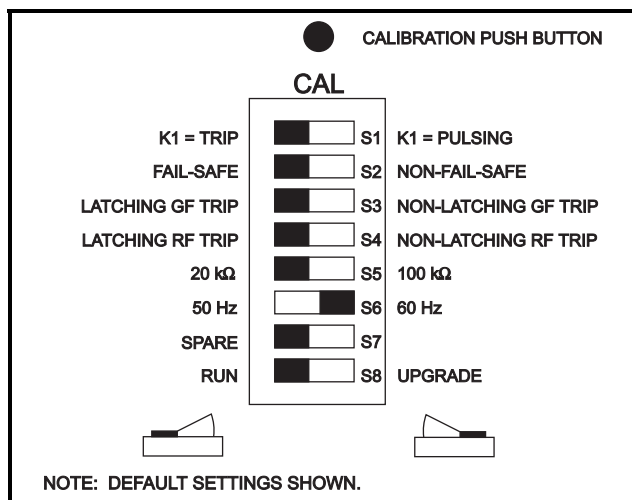

FIGURE 1. Configuration Switches.

#### 2.1.5.1 RELAY K1 FUNCTION (S1)

Set switch S1 to K1 = TRIP to assign the trip function to relay K1 and to activate switch S2. Relay K1 will change state when a resistor-fault or ground-fault trip occurs.

Set switch S1 to K1 = PULSING to configure relay K1 for pulsing operation and to activate PULSE-ENABLE terminals 16 and 17. Close the switch connecting terminals 16 and 17 to initiate pulsing. See Fig. 3 and Section 3.5.

#### 2.1.5.2 TRIP-RELAY MODE (S2)

Set switch S2 to select the operating mode of trip relay K1. In the non-fail-safe mode, relay K1 energizes and its contact closes when a trip occurs. The non-fail-safe mode can be used to trip shunt-trip circuit breakers. In the non-fail-safe mode, trips are reset when supply voltage is cycled.

In the fail-safe mode, relay K1 energizes and its contact closes if there are no trips. Contacts open if there is a trip, a loss of supply voltage, or a processor failure. In the fail-safe mode, trips are not reset when supply voltage is cycled.

**NOTE:** Switch S2 does not affect the operation of the ground-fault and resistor-fault indication relays.

**NOTE:** Switch S2 is only active when relay K1 is assigned the trip function (switch S1 set to K1 = TRIP).

#### 2.1.5.3 GROUND-FAULT-TRIP LATCH (S3)

Set switch S3 to select latching or non-latching ground-fault-circuit operation. See Section 2.4.

#### 2.1.5.4 RESISTOR-FAULT-TRIP LATCH (S4)

Set switch S4 to select latching or non-latching resistor-fault-circuit operation. See Section 2.4

#### 2.1.5.5 SENSING-RESISTOR SELECTION (S5)

Set switch S5 to the resistance of the sensing resistor. For the ER-600VC and ER-5KV, select 20 kΩ. For the ER-15KV, ER-25KV, and ER-35KV, select 100 kΩ. Switch S5 sets the  $V_N$  TRIP LEVEL range. See Section 2.1.3.



### 2.1.5.6 FREQUENCY (S6)

Set switch S6 to 50 or 60 Hz to tune the digital filter to the line frequency of the monitored system.

### 2.1.5.7 SPARE (S7)

### 2.1.5.8 UPGRADE ENABLE (S8)

Set switch S8 to RUN for normal operation or to UPGRADE to enable firmware upgrades. Changes in switch S8 settings are recognized only when supply voltage is cycled. Protection is disabled after supply voltage is cycled with S8 in the UPGRADE position. See Section 4.1.2.

## 2.2 CALIBRATION

The SE-330 measures the resistance change of the NGR relative to the NGR-resistance value determined at the time of calibration. Calibrate the SE-330 on new installations, if the NGR is changed, or if the sensing resistor is changed.

**NOTE:** If the SE-330 is not calibrated and is supplied from the load side of the breaker (non-fail-safe mode), calibrate within 12 seconds of power-up or it may trip and interrupt its supply.

The CALIBRATION push button is located behind the access cover on the front panel, and it is recessed to prevent inadvertent activation.

**NOTE:** Calibration must be performed with the SE-330 connected to the sensing resistor and NGR of the installed system.

To calibrate, press and hold the CALIBRATION push button until the green CALIBRATED LED turns off and returns to on (if the LED is already off, press and hold until the LED turns on). Calibration takes approximately two seconds. If calibration is not successful, a resistor-fault trip occurs, the RESISTOR FAULT TRIP LED will be on, the CALIBRATED LED will be off, and the DIAGNOSTIC LED will flash the calibration-error code. See Section 2.8.

If latching resistor fault (switch S4) is selected, the calibration-error code flashes until RESET is pressed even if the CALIBRATED LED is on.

The calibration value is stored in non-volatile memory.

## 2.3 PULSING OPERATION

If switch S1 is set to K1 = PULSING, pulsing occurs when terminal 16 is connected to terminal 17. Relay K1 operates at a 50% duty cycle and cycle time is adjustable from 1.0 to 3.0 seconds.

Relay K1 can be used to control a contactor rated for use at the line-to-neutral voltage. The contactor causes changes in neutral-to-ground resistance by adding or shorting portions of the NGR. See Section 3.5. Pulsing

ground-fault current appears as zero-sequence current upstream from the fault.

Pulsing ground-fault current is distinguishable from charging current and noise, and it can be traced with a clip-on ammeter or current probe. If pulsing current is detected on a cable or conduit, the fault is downstream. Systematic testing allows faults to be located without isolating feeders or interrupting loads. If the fault is on a conduit system with a complex mix of cables and ground points, the exact location of the ground fault may be difficult to determine.

Stop pulsing when the fault is located.

## 2.4 TRIP INDICATION AND RESET

Red LED's, fluorescent flags, and indication relays indicate ground-fault and resistor-fault trips—indication relays K2 and K3 are energized on trip. When a trip occurs with latching operation selected, the SE-330 remains tripped until reset. See Sections 2.1.5.3 and 2.1.5.4. Terminals 15 and 16 are provided for remote reset as shown in Fig. 3. The reset circuit responds only to a momentary closure so that a jammed or shorted switch does not prevent a trip. The front-panel RESET switch is inoperative when terminal 15 is connected to terminal 16. If non-latching operation is selected, trips and corresponding indication automatically reset when the fault clears.

The red DIAGNOSTIC LED annunciates latched calibration-error and remote trips. See Section 2.8.

Fluorescent flags retain their state when supply voltage is removed. When supply voltage is applied with switch S2 set to FAIL-SAFE, the SE-330 returns to its state prior to loss of supply voltage. When supply voltage is applied with switch S2 set to NON-FAIL-SAFE, SE-330 trips are reset; however, fluorescent flags are not reset. When a local, remote, or network reset is issued, both trip LED's will flash if they are off.

Resistor-fault-trip reset can take up to one second.

## 2.5 REMOTE OPERATION

Relays K2 and K3 can be used for remote indication, and terminals 15 and 16 are provided for remote reset. RK-332 Remote Indication and Reset components are shown in Fig. 14. Connect them as shown in Fig. 3. RK-332 components are not polarity sensitive.

Network-enabled SE-330's can be remotely tripped and reset by the network master. The red DIAGNOSTIC LED indicates a network-initiated trip. See Section 2.8. Refer to the appropriate SE-330 communications manual.

## 2.6 RELAY K1 LED

The yellow RELAY K1 LED follows the state of relay K1 and is on when K1 is energized (contact closed).



## 2.7 UNIT HEALTHY OUTPUT

UNIT HEALTHY relay K4 is energized when the processor is operating. It can be ordered with N.O. or N.C. contacts. See Section 7.

**NOTE:** The output changes state momentarily during a processor reset.

**NOTE:** K4-contact rating is 100 mA maximum.

## 2.8 DIAGNOSTIC LED

The DIAGNOSTIC LED is used to annunciate trips without individual LED indication. The number of short LED pulses between two long pulses indicates the cause of the trip.

Calibration-Error Trip (1 short):

The calibration resistance of the NGR is outside the calibration range. See Section 6.1.

Remote Trip (2 short):

The SE-330 has been tripped by a remote-trip command from the communications interface.

EEPROM-Error Trip (3 short):

An EEPROM error has been detected.

A/D-Converter-Error Trip (4 short):

An A/D-converter error has occurred.

Software-Interrupt Trip (5 short):

CPU reset was caused by a software interrupt.

Illegal-Opcode Trip (6 short):

CPU reset was caused by an illegal Opcode.

Watchdog Trip (7 short):

CPU reset was caused by the watchdog.

Clock-Failure Trip (8 short):

CPU reset was caused by an internal clock failure.

Trap-Code Trip (9 short):

This code is displayed if the supply is cycled after one of the previous four errors occurred.

Resistor-fault trips occur with all of the above trips. Ground-fault trips occur with all of the above trips except the calibration-error trip and the A/D-converter-error trip. See Troubleshooting Section 5.

## 2.9 ANALOG OUTPUT

An isolated 4–20-mA output indicates NGR current with full-scale output corresponding to the CT rating. An internal 24-Vdc supply allows the analog output to be connected as a self-powered output. Power from an external supply is required for loop-powered operation. See Fig. 2.

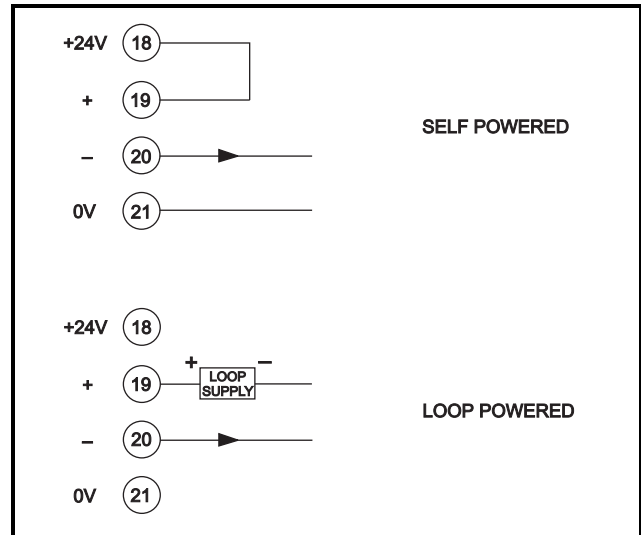

FIGURE 2. Analog-Output Connections.

## 3. INSTALLATION

### 3.1 SE-330

Outline and panel-cutout dimensions for the SE-330 are shown in Fig. 4. To panel mount the SE-330, insert it through the panel cutout and secure it with four 8-32 locknuts and flat washers (included).

All connections to the SE-330 are made with plug-in, wire-clamping terminal blocks. Each plug-in terminal block can be secured to the monitor by two captive screws for reliable connections.

Outline dimensions and mounting details for surface mounting the SE-330 are shown in Fig. 5. Fasten the surface-mount adapter to the mounting surface and make connections to the adapter terminal blocks. Follow Fig. 5 instructions to mount or remove the SE-330.

Ground terminal 7 (G) and connect terminal 6 (R) to the sensing-resistor R terminal.

Use terminal 1 (L1) as the line terminal on ac systems, or the positive terminal on dc systems. Use terminal 2 (L2/N) as the neutral terminal on ac systems or the negative terminal on dc systems. Connect terminal 3 (⊕) to ground. Connect terminal 4 (SPG) to terminal 5 (SPGA). Remove the terminal-4-to-5 connection for dielectric-strength testing.

**NOTE:** When the terminal-4-to-5 connection is removed, protective circuits inside the SE-330 are disconnected to allow dielectric strength testing of a control panel without having to disconnect wiring to the SE-330. Ensure that the terminal-4-to-5 connection is replaced after testing.

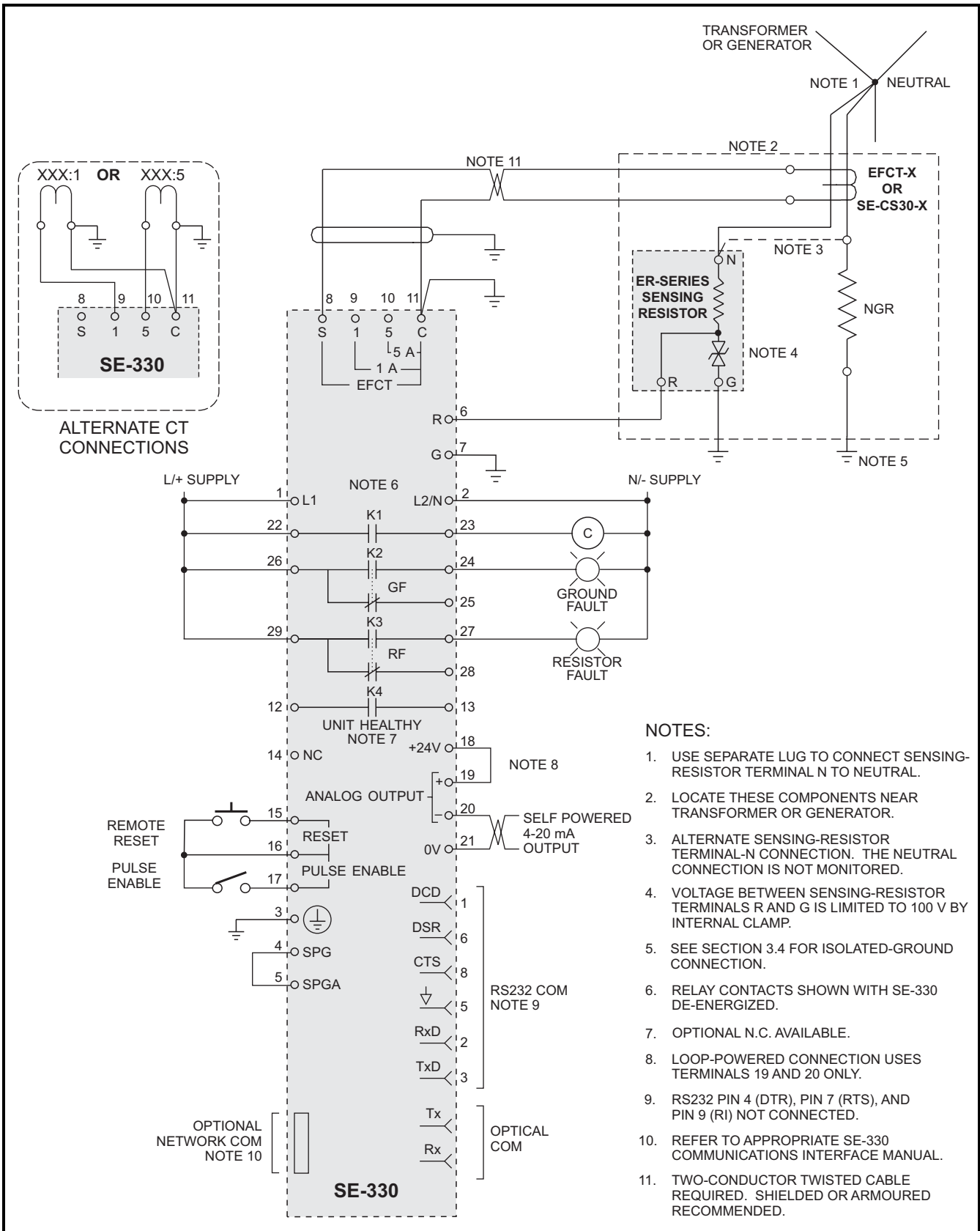

- NOTES:**
1. USE SEPARATE LUG TO CONNECT SENSING-RESISTOR TERMINAL N TO NEUTRAL.
  2. LOCATE THESE COMPONENTS NEAR TRANSFORMER OR GENERATOR.
  3. ALTERNATE SENSING-RESISTOR TERMINAL-N CONNECTION. THE NEUTRAL CONNECTION IS NOT MONITORED.
  4. VOLTAGE BETWEEN SENSING-RESISTOR TERMINALS R AND G IS LIMITED TO 100 V BY INTERNAL CLAMP.
  5. SEE SECTION 3.4 FOR ISOLATED-GROUND CONNECTION.
  6. RELAY CONTACTS SHOWN WITH SE-330 DE-ENERGIZED.
  7. OPTIONAL N.C. AVAILABLE.
  8. LOOP-POWERED CONNECTION USES TERMINALS 19 AND 20 ONLY.
  9. RS232 PIN 4 (DTR), PIN 7 (RTS), AND PIN 9 (RI) NOT CONNECTED.
  10. REFER TO APPROPRIATE SE-330 COMMUNICATIONS INTERFACE MANUAL.
  11. TWO-CONDUCTOR TWISTED CABLE REQUIRED. SHIELDED OR ARMoured RECOMMENDED.

FIGURE 3. SE-330 Connection Diagram.

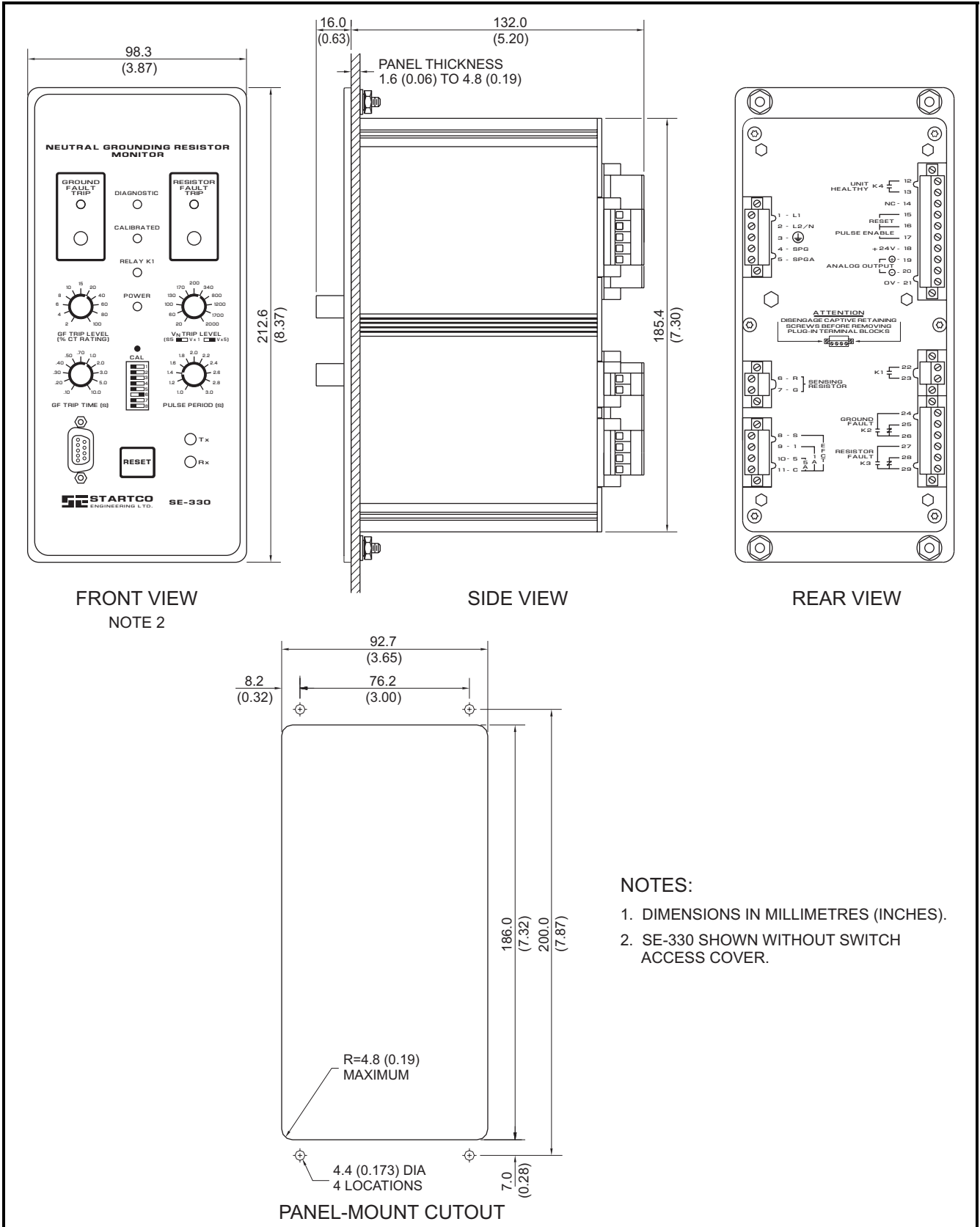

FIGURE 4. SE-330 Outline and Panel-Mounting Details.

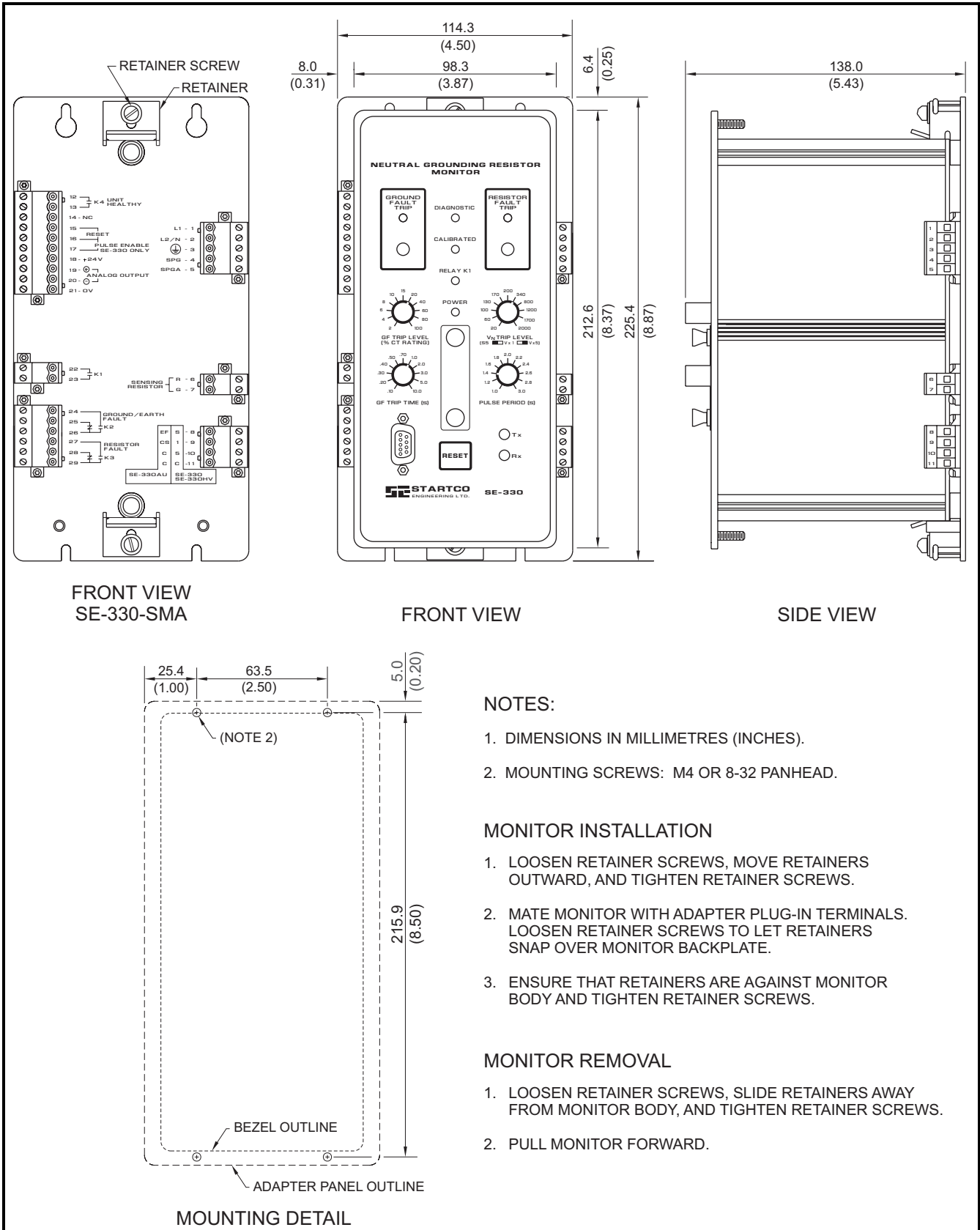

FIGURE 5. SE-330 Outline and Surface-Mounting Details.

### 3.2 SENSING RESISTOR

Outline and mounting details for ER-600VC, ER-5KV, ER-15KV, ER-25KV, and ER-35KV sensing resistors are shown in Figs. 6, 7, 8, 9, and 10. Locate the NGR and the sensing resistor near the transformer or generator. When located outdoors, a sensing resistor must be installed in a suitable enclosure. Ground sensing-resistor terminal G. Pass the sensing-resistor-to-neutral conductor and the NGR-to-neutral conductor through the ground-fault-CT window as shown in Fig. 3. Separately connect sensing-resistor terminal N and the NGR to the neutral to include neutral connections in the monitored loop. If a ground fault in the sensing-resistor conductor is unlikely, a minimal loss of

protection will result if it does not pass through the ground-fault-CT window. See Note 3 in Fig. 3.

**CAUTION:** Voltage at terminal N rises to line-to-neutral voltage when a ground fault occurs. The same clearances are required for sensing resistors as for NGR's.

**NOTE:** The neutral-to-sensing-resistor-terminal-N connection is not a neutral conductor as defined in Canadian Electrical Code Section 10-1108 and National Electrical Code Section 250.36(B). It is not required to be 8 AWG or larger. Since current through this conductor is always less than 250 mA, a 14 AWG conductor insulated to the system voltage is more than sufficient.

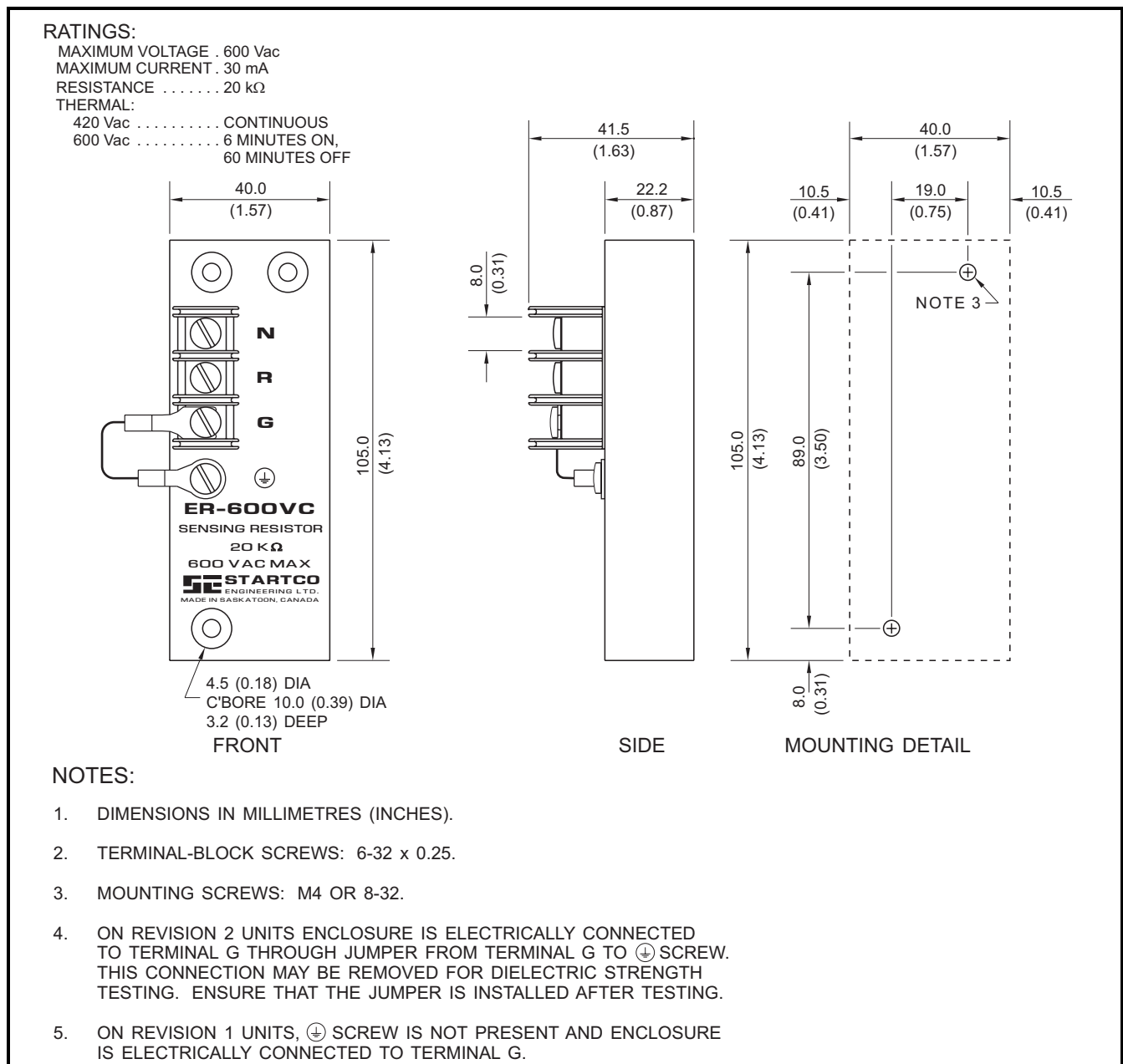
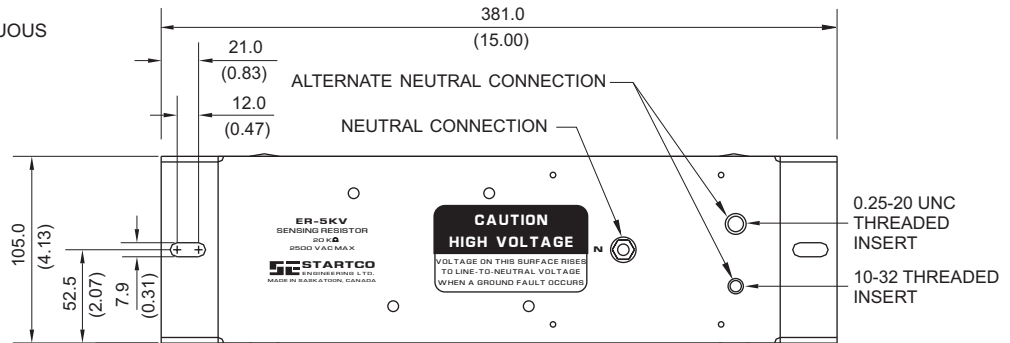

FIGURE 6. ER-600VC Sensing Resistor.



**RATINGS:**

MAXIMUM VOLTAGE . 2,500 Vac  
 MAXIMUM CURRENT . 125 mA  
 RESISTANCE . . . . . 20 kΩ  
 THERMAL . . . . . CONTINUOUS



TOP VIEW

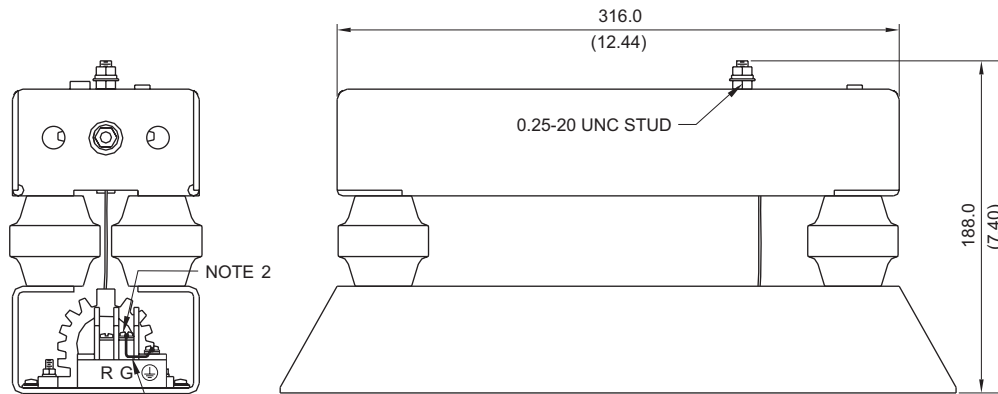

SIDE VIEW

FRONT VIEW

**NOTES:**

1. DIMENSIONS IN MILLIMETRES (INCHES).
2. TERMINAL-BLOCK SCREWS: 6-32 x 0.25.
3. MOUNTING SCREWS: M6 OR 0.25-20.
4. THIS DEVICE CAN DISSIPATE 300 WATTS. TO MINIMIZE SURFACE TEMPERATURES FOR SYSTEMS ALLOWED TO OPERATE CONTINUOUSLY WITH A GROUND FAULT, MOUNT VERTICALLY WITH R & G TERMINALS DOWN.
5. ON REVISION 2 UNITS BASE IS ELECTRICALLY CONNECTED TO TERMINAL G THROUGH JUMPER FROM TERMINAL G TO ⊕ SCREW. THIS CONNECTION MAY BE REMOVED FOR DIELECTRIC STRENGTH TESTING. ENSURE THAT THE JUMPER IS INSTALLED AFTER TESTING.
6. ON REV 0 & 1 UNITS ⊕ SCREW IS NOT PRESENT AND BASE IS ELECTRICALLY CONNECTED TO TERMINAL G.

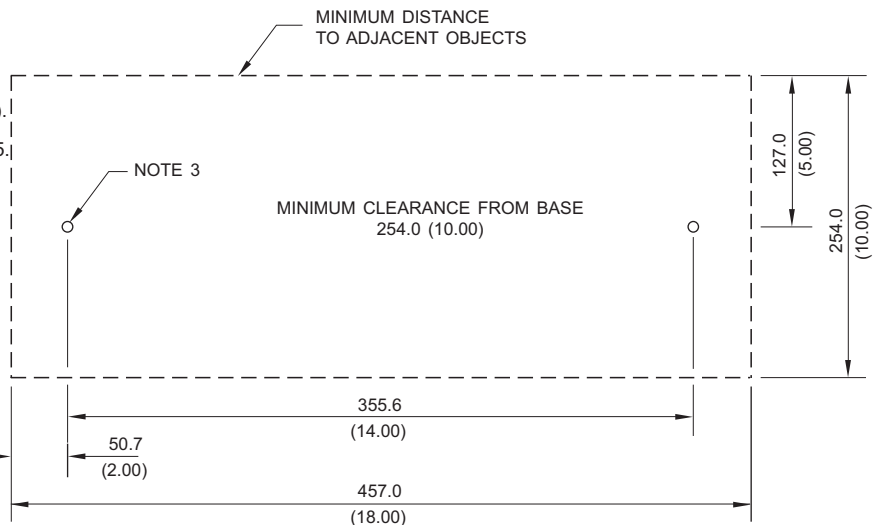

MOUNTING DETAIL

REVISION 1, 030507

FIGURE 7. ER-5KV Sensing Resistor.

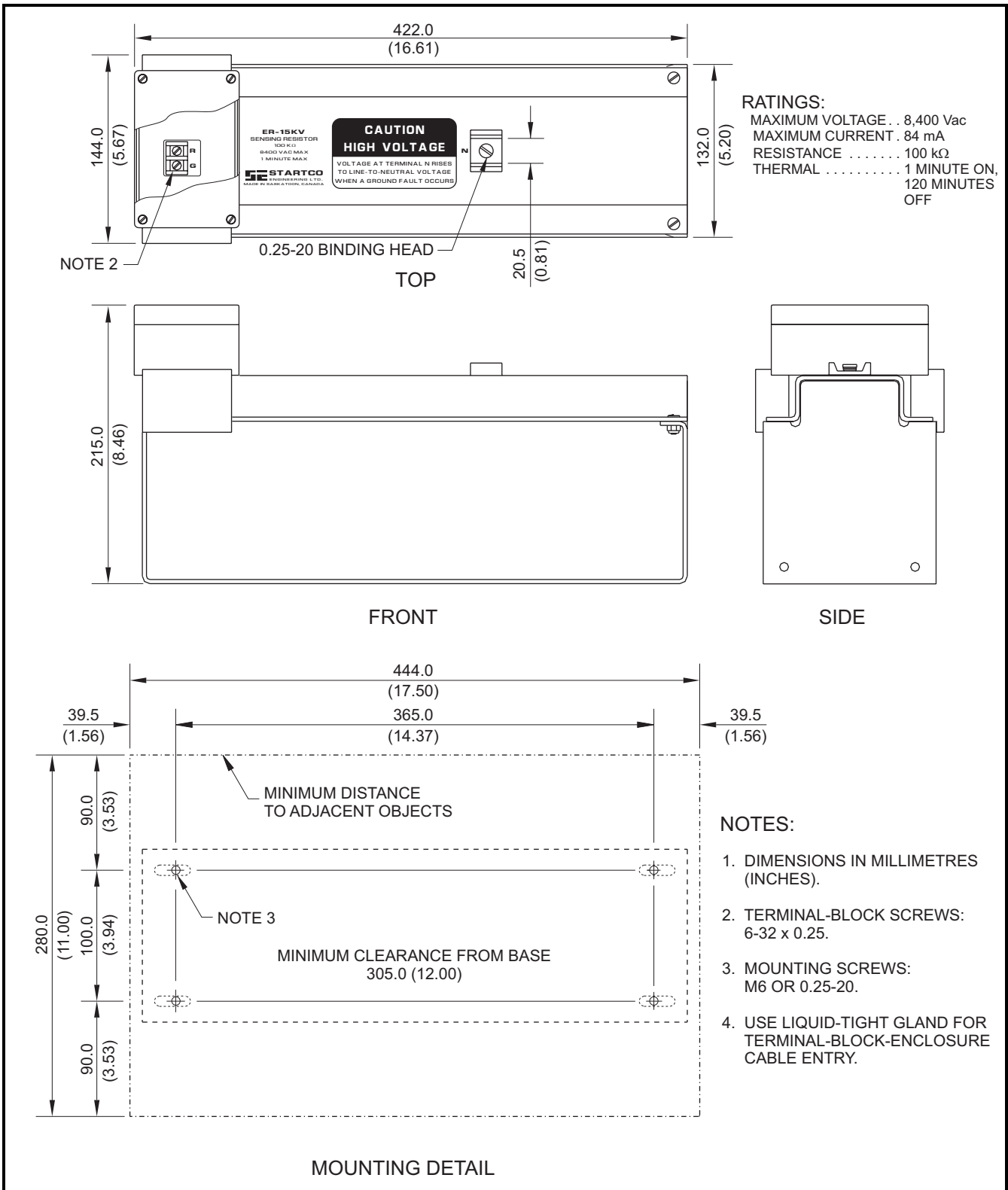

FIGURE 8. ER-15KV Sensing Resistor.

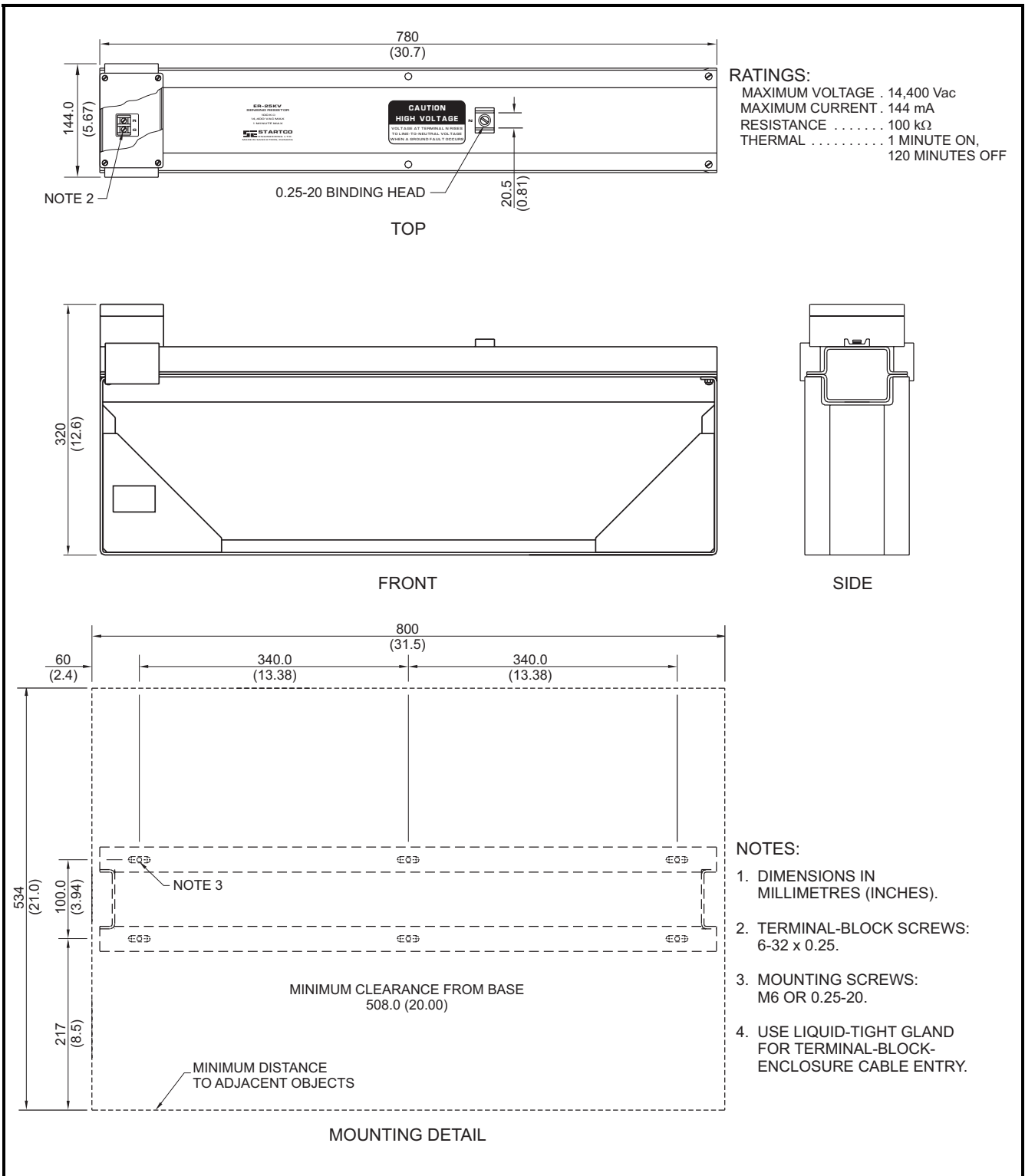

FIGURE 9. ER-25KV Sensing Resistor.

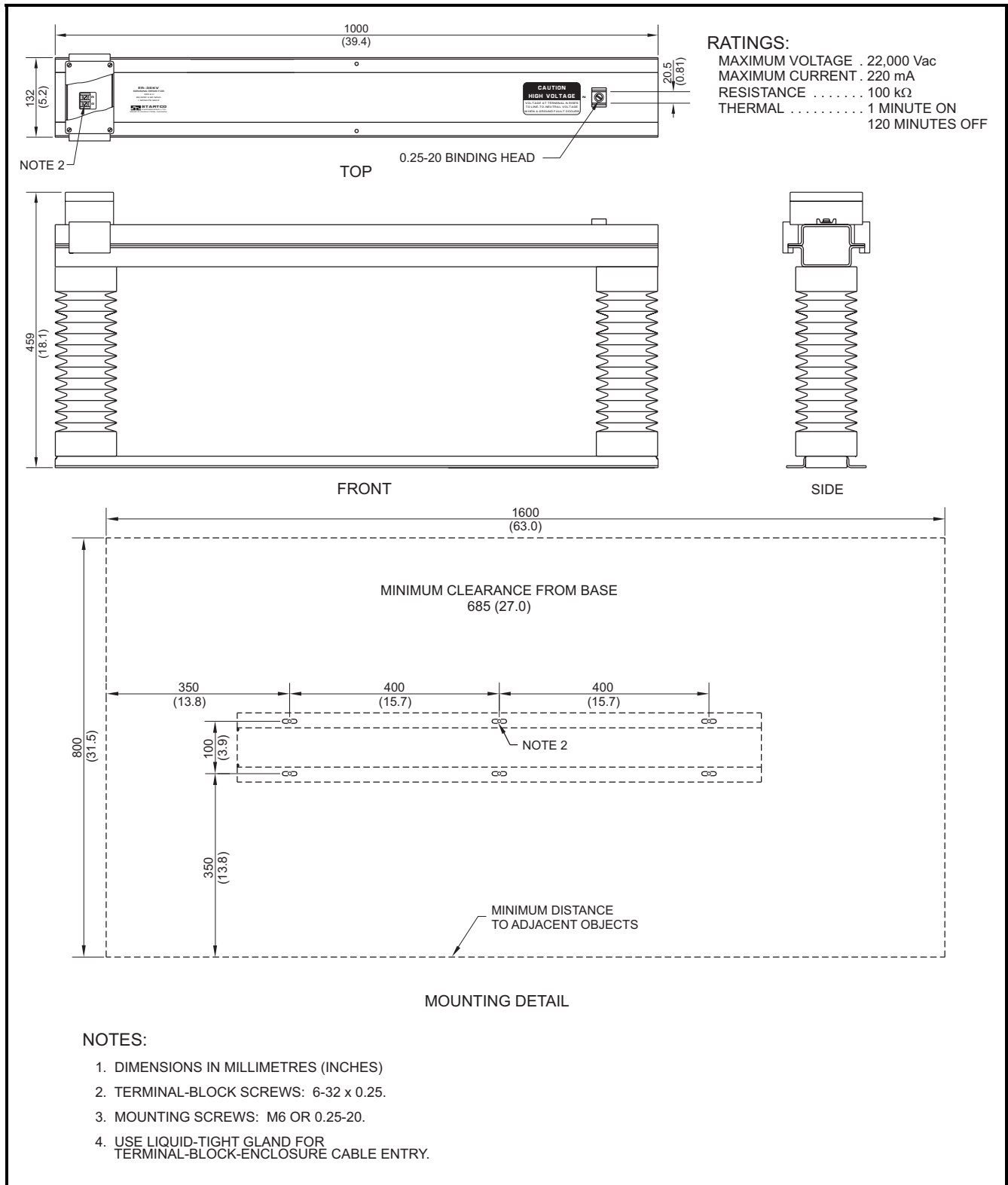

FIGURE 10. ER-35KV Sensing Resistor.

### 3.3 GROUND-FAULT CT

Select and install a ground-fault CT that will provide the desired trip level. Typically, the CT-primary rating should approximately equal the NGR let-through-current rating. This provides an appropriate GF TRIP LEVEL setting range and analog-output scaling. See Sections 2.1.2 and 2.9.

Outline and mounting details for the sensitive EFCT- and SE-CS30-series current sensors are shown in Figs. 11, 12, and 13. Ground-fault-CT connections and the typical ground-fault-CT location are shown in Fig. 3.

For SE-325 replacement applications, the existing CT200 current transformer will typically have to be replaced. However, where replacement is not necessary or possible, the CT200 can be connected to either the 1- or 5-A input. This CT has a 200:5 current ratio. If

connected to the 1-A input, the ground-fault trip level will be a percentage of 40 A. See Section 2.1.2.

The accuracy of a typical current transformer, including the CT200, decreases below 5% of its current rating. CT-primary current injection testing is recommended to verify trip levels below 5% of the CT-primary rating. See Section 9.4. Startco sensitive current sensors are designed for use at low levels and respond linearly to 2% current.

**NOTE:** The current-transformer insulation class is of no consequence if its secondary is grounded and the conductors through its window are insulated for the system voltage. Medium-voltage systems may require a bushing-type CT.

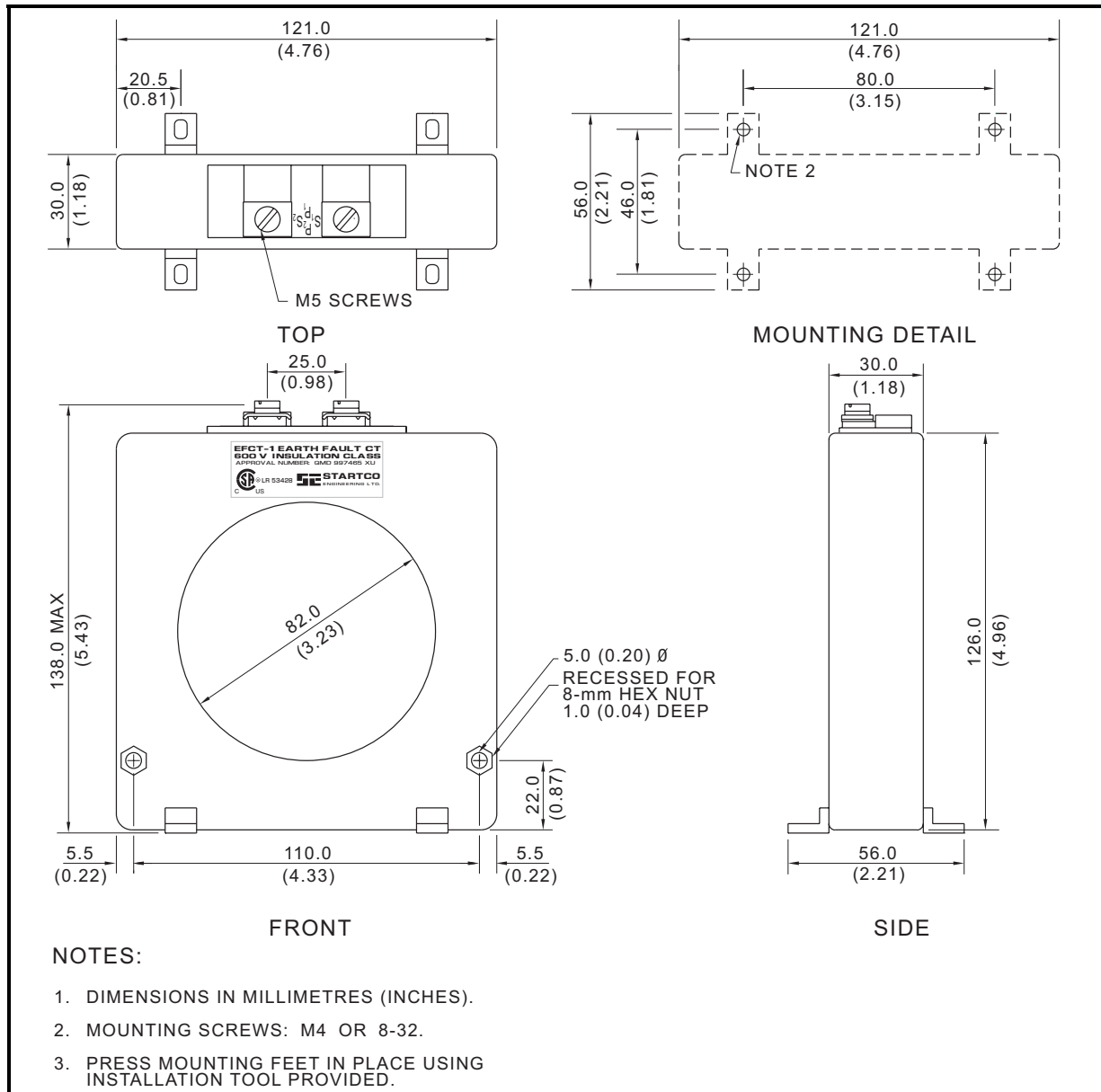

FIGURE 11. EFCT-1 Sensitive Ground-Fault Current Sensor.

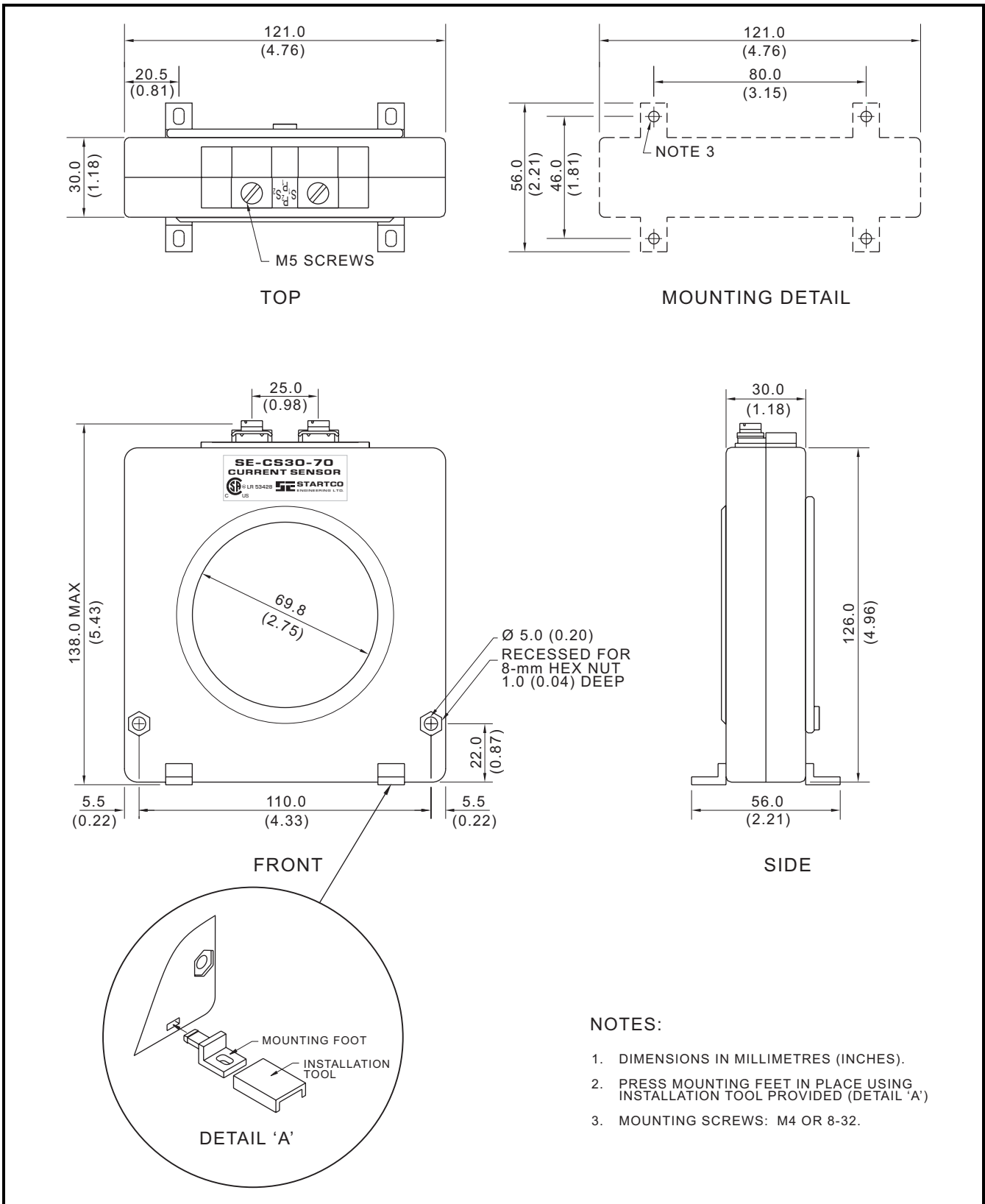

FIGURE 12. SE-CS30-70 Sensitive Ground-Fault Current Sensor.

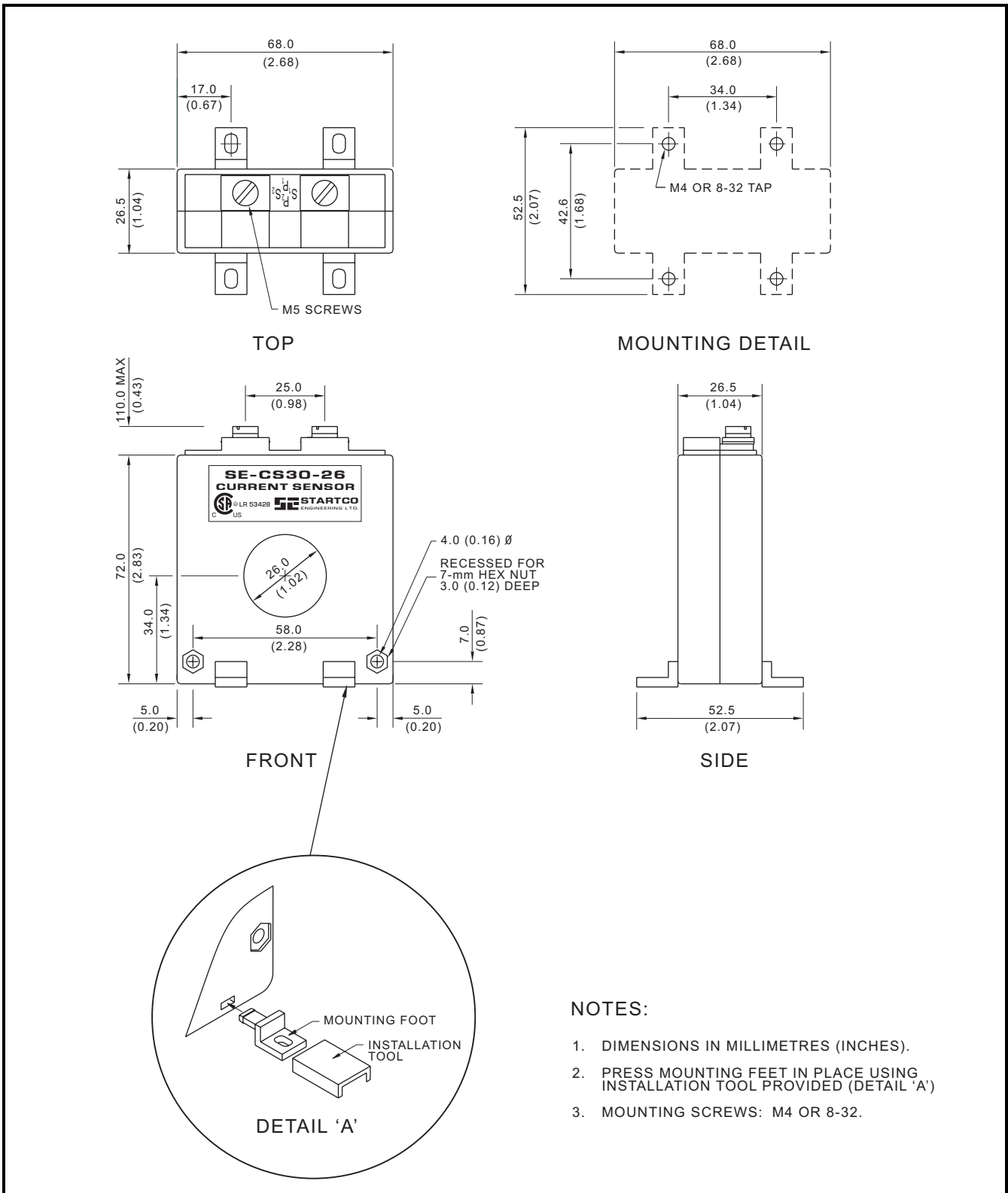

FIGURE 13. EFCT-26 and SE-CS30-26 Sensitive Ground-Fault Current Sensors.

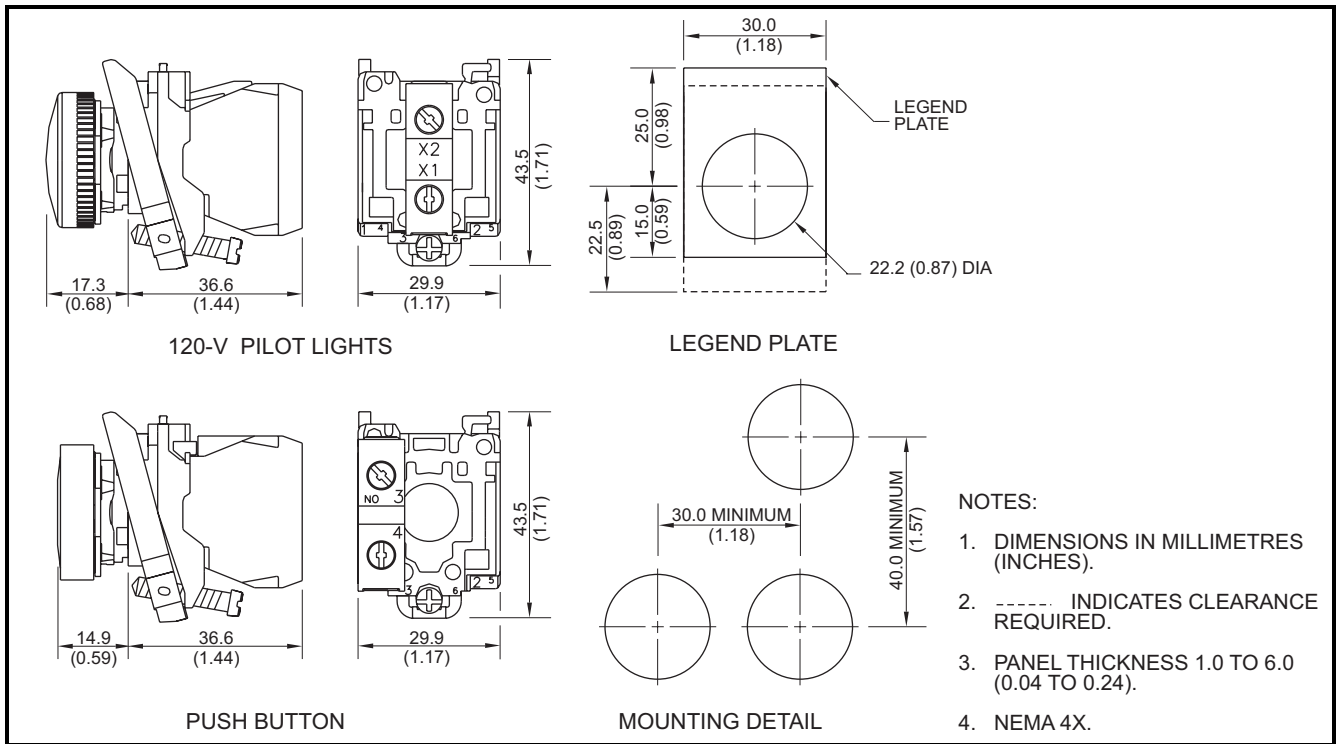

FIGURE 14. RK-332 Remote Indication and Reset.

### 3.4 ISOLATED GROUND CONNECTION

An isolated ground bed can prevent a ground potential rise (GPR) from being transferred to remote equipment. If the G terminals on the sensing resistor and the SE-330 are connected to an isolated ground, the SE-330 will be exposed to the GPR. If the GPR is greater than the terminal-block rating, the SE-330 must be isolated from station ground and precautions must be taken with the power supply and the trip contacts. See Technical Information 3.1 “NGR Monitoring with Isolated Ground Beds” at [www.startco.ca](http://www.startco.ca).

A configuration which allows an SE-330 to be connected to station ground is shown in Fig. 15. The SE-330 monitors the series combination of the NGR and the two ground beds. This configuration is acceptable provided the series resistance of the NGR and the ground beds is within the NGR calibration range and ground-bed-resistance changes remain within the trip range. See Section 6.1.

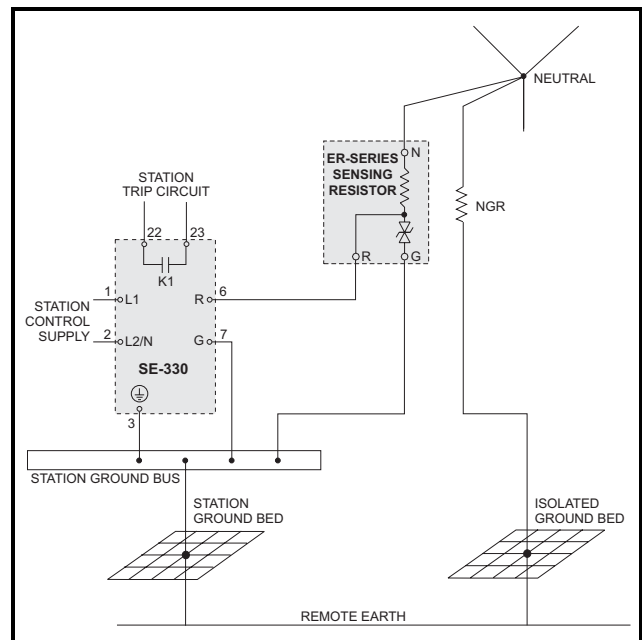

FIGURE 15. Simplified Isolated-Ground Connection.

### 3.5 PULSING CONNECTION

Set switch S1 to K1 = PULSING and use an external switch as shown in Fig. 16 to use relay K1 to control a pulsing contactor. Relays K2 and K3 can be used for tripping; however, they operate in the non-fail-safe mode only.

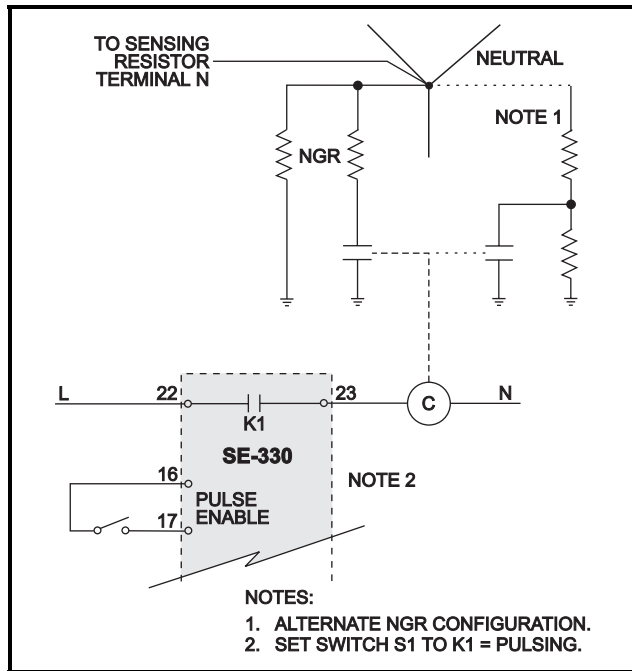

FIGURE 16. Simplified Pulsing Connection.

## 4. COMMUNICATIONS

### 4.1 LOCAL COMMUNICATION PORTS

The SE-330 has two local communications ports; an RS-232 port and a fibre-optic port. Port operation is mutually exclusive. Both ports are designed for use with firmware-upgrade and system-monitoring software running on a PC.

The RS-232 port is non-isolated and operates as a DCE device with the connector (socket contacts) pin-out listed in Table 3. This port allows direct connection to a PC using standard DB-9 connector cables. Cable length should not exceed 10 metres.

TABLE 3. RS-232 DB-9 TERMINALS

PIN #	SIGNAL NAME	COMMENTS
1	DCD	470 Ω connected to +12 V
2	RD	Output to DTE from SE-330
3	TD	Input from DTE to SE-330
4	DTR	Not connected
5	SG	Signal Ground
6	DSR	470 Ω connected to +12 V
7	RTS	Not connected
8	CTS	470 Ω connected to +12 V
9	RI	Not connected

The fibre-optic port provides isolated local communications up to 500 metres. Standard V-pin connectors are located on the SE-330 front panel. An appropriate fibre-optic cable and an SE-OPT232 fibre-optic/RS-232 converter at the PC are required. Use connector plugs to protect the fibre optic port when it is not in use.

### 4.1.1 LOCAL DATA ACQUISITION

The SE-330 outputs a data packet every second. Data output is in the standard UART data format of eight data bits and one stop bit. The baud rate is fixed at 38,400 bits per second. Use PC program SE-MON330 or PDA program SE-PDA330 to display the following data:

- SE-330 settings and switch states.
- Neutral voltage and current.
- Resistance change.
- Trip status.
- Pending trips.
- Relay and LED status.
- NGR calibration value.
- Firmware revision level.

Data can be logged to a PC file at user-defined time intervals for future analysis.

### 4.1.2 FIRMWARE UPGRADE

The local ports can be used to upgrade the SE-330 firmware. Upgrade procedure:

- 1) Remove supply voltage.
- 2) Set switch S8 to UPGRADE.
- 3) Apply supply voltage. The DIAGNOSTIC LED will be on and all relays will be de-energized.
- 4) Run SE-FLASH and follow the instructions.
- 5) Remove supply voltage.
- 6) Set switch S8 to RUN.
- 7) Apply supply voltage.

SE-MON330 and SE-FLASH are available at [www.startco.ca](http://www.startco.ca).

### 4.2 NETWORK COMMUNICATIONS

The SE-330 interface for optional communications modules presently supports DeviceNet™, PROFIBUS®, and Ethernet:

DeviceNet™:

- DeviceNet Slave.
- DeviceNet specification Vol 1:2.0, Vol 2:20.

PROFIBUS®:

- PROFIBUS-DP Slave according to IEC61158.



Ethernet:

- Modbus TCP Class 0, 1.
- Ethernet/IP Level 2 I/O Server CIP (ControlNet and DeviceNet)
- WebServer, on-board selection of IP address.

- Read trip status.
- Reset trips.
- Perform a remote trip.
- Access the last ten trip records. Each trip record contains the cause of trip and the pre-trip NGR current, voltage, and resistance values.

Communications options allow the user to:

- Read SE-330 settings.
- Read neutral voltage and current.
- Read resistance change.

Refer to the appropriate SE-330 communications-interface manual.

## 5. TROUBLESHOOTING

PROBLEM	SOLUTION
POWER LED off.	Check if supply voltage is present on terminals 1 and 2. If present, an overvoltage may have caused the power supply to shutdown. Cycle supply voltage. If POWER LED remains off, return unit for repair.
POWER LED flashes.	A power-supply overload has occurred. Cycle supply voltage. If problem persists, consult Startco.
<b>Calibration-Error Trip</b> DIAGNOSTIC LED flash code = L-S-L...*	The total resistance of the NGR and sensing-resistor circuit is outside the calibration range. Verify that switch S5 is set to match the resistance of the sensing resistor, check the resistance of the NGR, and verify the sensing-resistor circuit. See Section 9.2 for sensing-resistor tests.  Repeat the calibration procedure after the open or shorted condition has been corrected.
<b>Remote Trip</b> DIAGNOSTIC LED flash code = L-S-S-L...*	The SE-330 was tripped by a signal from network communications. Press RESET to clear the trip.
<b>EEPROM-Error Trip</b> DIAGNOSTIC LED flash code = L-S-S-S-L...*	An error was detected in the EEPROM. Press RESET to clear the trip. If the problem persists, consult Startco.
<b>A/D-Converter-Error Trip</b> DIAGNOSTIC LED flash code = L-S-S-S-S-L...*	An A/D-converter error was detected. Press RESET to clear the trip. If the problem persists, consult Startco.
<b>Software-Interrupt Trip</b> DIAGNOSTIC LED flash code = L-S-S-S-S-S-L...*	These four errors result in a processor reset. During reset, UNIT HEALTHY relay K4 will be de-energized. After a reset, UNIT HEALTHY relay K4 will be energized. Press RESET to clear the trip. If the problem persists, consult Startco.
<b>Illegal-Opcode Trip</b> DIAGNOSTIC LED flash code = L-S-S-S-S-S-S-L...*	When supply voltage is cycled, the specific error code is lost but the Trap Code will be displayed.
<b>Watchdog Trip</b> DIAGNOSTIC LED flash code = L-S-S-S-S-S-S-S-L...*	
<b>Clock-Failure Trip</b> DIAGNOSTIC LED flash code = L-S-S-S-S-S-S-S-S-L...*	
<b>Trap-Code Trip</b> DIAGNOSTIC LED flash code = L-S-S-S-S-S-S-S-S-S-L...*	This code is displayed if the supply is cycled after one of the previous four errors occurred. Press RESET to clear the trip.
DIAGNOSTIC LED = Solid Red	Switch S8 is in the UPGRADE position. If firmware upgrade is not required, set switch S8 to RUN and cycle supply. SE-330 processor failed to start. Cycle supply. Consult Startco if problem persists.
Trip LED's are off but a trip flag is on.	Normal operation. See Section 2.4. Press RESET to force flags to the off state.
Pressing RESET does not clear trips.	Trip condition is still present. Locate and correct. The face-plate RESET button is disabled if remote-reset terminals 15 and 16 are connected. Replace shorted remote-reset switch or issue Reset command from the communications network.
UNIT HEALTHY relay K4 momentarily changes state.	Occurs when processor is reset.
GROUND-FAULT and RESISTOR-FAULT LED's flash during reset.	Normal operation.
No analog-output current.	The output at terminals 19 and 20 requires a voltage source. See Fig. 2 for analog-output connections. See Section 9.3 for the analog-output tests.

\*L = long, S = short.



## 6. TECHNICAL SPECIFICATIONS

### 6.1 SE-330

Supply	
Option 0.....	30 VA, 65 to 265 Vac, 40 to 400 Hz. 20W, 80 to 275 Vdc
Option 2.....	20 W, 36 to 72 Vdc 35 VA, 32 to 52 Vac, 40 to 400 Hz
Power-Up Time .....	250 ms at 120 Vac
AC Measurements .....	Discrete Fourier Transform. 16 samples per cycle, 50 or 60 Hz
Resistor-Fault Circuit:	
Neutral-To-Ground Voltage Trip Levels:	
ER-600VC or ER-5KV .....	20; 60; 100; 130; 170; 200; 340; 800; 1,200; 1,700; 2,000 Vac
ER-15KV to ER-35KV .....	100; 300; 500; 650; 850; 1,000; 1,700; 4,000; 6,000; 8,500; 10,000 Vac
Accuracy .....	5% of setting
NGR Calibration Range:	
ER-600VC or ER-5KV .....	0 to 2 k $\Omega$
ER-15KV to ER-35KV .....	0 to 10 k $\Omega$
Trip Resistance, $V_N = 0$ :	
ER-600VC or ER-5KV .....	500- $\Omega$ change $\pm$ 200 $\Omega$
ER-15KV to ER-35KV .....	2.5-k $\Omega$ change $\pm$ 1 k $\Omega$
Neutral-To-Ground DC-Voltage Rejection:	
ER-600VC or ER-5KV .....	25 Vdc
ER-15KV to ER-35KV .....	125 Vdc
Trip Time.....	12 $\pm$ 1 s
Trip Hold-Off Level .....	5% of CT-Primary Rating
Operating Mode .....	Latching/Non-Latching
Ground-Fault Circuit:	
Trip Level.....	2, 4, 6, 8, 10, 15, 20, 40, 60, 80, 100% of CT-Primary Rating
Trip Time.....	0.1, 0.2, 0.3, 0.4, 0.5, 0.7, 1.0, 2.0, 3.0, 5.0, 10.0 s
Trip-Level Accuracy.....	1% of CT-Primary Rating
Trip-Time Accuracy .....	10% of Setting
Maximum CT lead resistance:	
EFCT & SE-CS30 .....	5 $\Omega$
Other CT's.....	Consult CT Curve.
CT-Input Burden:	
5-A Input .....	< 0.01 $\Omega$
1-A Input .....	< 0.05 $\Omega$
EFCT Input .....	< 10 $\Omega$

#### Thermal Withstand:

##### 1-A and 5-A Input:

Continuous ..... 2 x CT Rating

1-Second..... 20 x CT Rating

##### EFCT Input:

Continuous ..... 10 x CT Rating

1-Second..... 25 x CT Rating

Measurement Range ..... 25 x CT-Primary Rating

Operating Mode..... Latching/Non-Latching

#### Pulsing Circuit:

Pulse Period..... 1.0 to 3.0 s,  
0.2-s increments

Duty Cycle ..... 50%

Time Accuracy..... 10% of Setting

#### Trip/Pulsing Relay K1 Contacts:

Configuration ..... N.O. (Form A)

Operating Mode..... Fail-Safe or Non-Fail-Safe

CSA/UL Contact Ratings ..... 8 A resistive 250 Vac,  
5 A resistive 30 Vdc

#### Supplemental Contact Ratings:

Make/Carry 0.2 s ..... 30 A

##### Break:

dc ..... 75 W resistive,

35 W inductive

(L/R = 0.04)

ac ..... 2,000 VA resistive,

1,500 VA inductive

(PF = 0.4)

Subject to maximums of 8 A and 250 V (ac or dc).

#### GF (K2) and RF (K3) Relay Contacts:

Configuration ..... N.O. and N.C. (Form C)

Operating Mode..... Non-Fail-Safe

CSA/UL Contact Ratings ..... 8 A resistive 250 Vac,  
8 A resistive 30 Vdc

#### Supplemental Contact Ratings:

Make/Carry 0.2s ..... 20 A

##### Break:

dc ..... 50 W resistive,

25 W inductive

(L/R = 0.04)

ac ..... 2,000 VA resistive,

1,500 VA inductive

(PF = 0.4)

Subject to maximums of 8 A and 250 V (ac or dc).

#### UNIT HEALTHY Output K4 (Option 00):

Configuration ..... N.O. (Form A)

Operating Mode..... Closed when Healthy

Ratings..... 100 mA, 250 V (ac or dc)

Closed Resistance ..... 30  $\Omega$  maximum

#### UNIT HEALTHY Output K4 (Option 01):

Configuration ..... N.C. (Form B)

Operating Mode..... Open when Healthy

Ratings..... 100 mA, 250 V (ac or dc)

Closed Resistance ..... 30  $\Omega$  maximum



4–20-mA Analog Output:

Type .....	Self Powered and Loop Powered
Range .....	4 to 22 mA
Loop Voltage .....	8 to 36 Vdc
Load .....	500 Ω (maximum with 24-Vdc supply)
Isolation .....	120 Vac
Parameter .....	NGR Current

RS-232 Communications:

Baud Rate .....	38.4 kbit/s
Protocol .....	Proprietary

Terminal-Block Ratings ..... 10 A, 300 Vac, 12 AWG

PWB Conformal Coating ..... MIL-1-46058 qualified,  
UL QMJU2 recognized

Mounting Configurations ..... Panel Mount and Surface  
Mount

Shipping Weight ..... 2.0 kg (4.4 lbs)

Environment:

Operating Temperature .....	-40 to 60°C
Storage Temperature .....	-55 to 80°C
Humidity .....	85% Non-Condensing

Surge Withstand ..... ANSI/IEEE C37.90.1-  
1989 (Oscillatory and Fast  
Transient)

EMC ..... EN 55011:1998

Certification ..... CSA, Canada and USA



Australia



**6.2 SENSING RESISTORS**

ER-600VC:

Maximum Voltage .....	600 Vac
Maximum Current .....	30 mA
Resistance .....	20 kΩ
Thermal .....	Continuous
Shipping Weight .....	300 g (0.7 lb)

ER-5KV:

Maximum Voltage .....	2,500 Vac
Maximum Current .....	125 mA
Resistance .....	20 kΩ
Thermal .....	Continuous
Shipping Weight .....	5.0 kg (11 lbs)

ER-15KV:

Maximum Voltage .....	8,400 Vac
Maximum Current .....	84 mA
Resistance .....	100 kΩ
Thermal .....	1 minute on, 120 minutes off
Shipping Weight .....	5.0 kg (11 lbs)

ER-25KV:

Maximum Voltage .....	14,400 Vac
Maximum Current .....	144 mA
Resistance .....	100 kΩ
Thermal .....	1 minute on, 120 minutes off
Shipping Weight .....	20 kg (44 lbs)

ER-35KV:

Maximum Voltage .....	22,000 Vac
Maximum Current .....	220 mA
Resistance .....	100 kΩ
Thermal .....	1 minute on, 120 minutes off
Shipping Weight .....	40 kg (88 lbs)

Certification ..... CSA, Canada and USA



**6.3 CURRENT SENSORS**

EFCT-1:

Current Ratio .....	5:0.05 A
Insulation .....	600-V Class
Window Diameter .....	82 mm (3.2")
Shipping Weight .....	900 g (2.0 lbs)

EFCT-26

Current Ratio .....	5:0.05 A
Insulation .....	600-V Class
Window Diameter .....	26 mm (1.0")
Shipping Weight .....	450 g (1.0 lb)

SE-CS30-26

Current Ratio .....	30:0.05 A
Insulation .....	600-V Class
Window Diameter .....	26 mm (1.0")
Shipping Weight .....	450 g (1.0 lb)

SE-CS30-70

Current Ratio .....	30:0.05 A
Insulation .....	600-V Class
Window Diameter .....	70 mm (2.7")
Shipping Weight .....	1.2 kg (2.5 lbs)



## 7. ORDERING INFORMATION

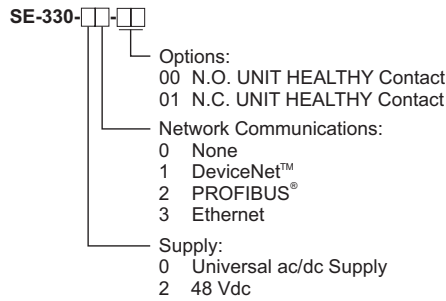

### Sensing Resistors:

ER-600VC	For system voltages up to 1 kVac
ER-5KV	For system voltages up to 5 kVac
ER-15KV	For system voltages up to 15 kVac
ER-25KV	For system voltages up to 25 kVac
ER-35KV	For system voltages up to 35 kVac

### Current Transformers:

EFCT-1	Sensitive Ground-Fault CT, 5-A-primary rating, 82-mm (3.2") window
EFCT-26	Sensitive Ground-Fault CT, 5-A-primary rating, 26-mm (1.0") window
SE-CS30-26	Sensitive Ground-Fault CT, 30-A-primary rating, 26-mm (1.0") window
SE-CS30-70	Sensitive Ground-Fault CT, 30-A-primary rating, 70-mm (2.7") window

### Accessories:

RK-332	Remote Indication and Reset, Includes two 120-V pilot lights, a reset push button, and legend plates
SE-OPT232	Port-Powered Fibre-Optic/RS-232 Converter

### Software: <sup>(1)</sup>

SE-FLASH	Firmware Upgrade Program
SE-MON330	SE-330 Data-Display Program for PC
SE-PDA330	SE-330 Data-Display Program for PDA

<sup>(1)</sup> Available at [www.startco.ca](http://www.startco.ca).

## 8. WARRANTY

The SE-330 Neutral-Grounding-Resistor Monitor is warranted to be free from defects in material and workmanship for a period of five years from the date of purchase.

Startco Engineering Ltd. will (at Startco's option) repair, replace, or refund the original purchase price of an SE-330 that is determined by Startco to be defective if it is returned to the Startco factory, freight prepaid, within the warranty period. This warranty does not apply to repairs required as a result of misuse, negligence, an accident, improper installation, tampering, or insufficient care. Startco Engineering Ltd. does not warrant products repaired or modified by non-Startco Engineering Ltd. personnel.

Startco Engineering Ltd. is not liable for contingent or consequential damages; for expenses sustained as a result of incorrect application, incorrect adjustment, or a malfunction; or for expenses resulting from the use of, or inability to use, the product.

## 9. TEST PROCEDURES

### 9.1 RESISTOR-FAULT TESTS

Perform tests with system de-energized and supply voltage applied to the SE-330.

#### 9.1.1 CALIBRATION AND OPEN TEST

Test Equipment: 20-kΩ and 100-kΩ, 1/4-watt, 1% calibration resistors (calibration resistors are supplied with SE-330).

#### Procedure:

- Remove connections to terminals 6 and 7.
- Connect the 20-kΩ resistor to terminals 6 and 7.
- Set switch S5 to the 20-kΩ position.
- Perform calibration as per Section 2.2.
- The CALIBRATED LED should be on.
- Press RESET.
- Remove the 20-kΩ resistor and wait for 12 seconds.  
**PASS:** The SE-330 should trip on resistor fault.
- Connect the 100-kΩ resistor to terminals 6 and 7.
- Set switch S5 to the 100-kΩ position.
- Perform calibration as per Section 2.2.
- The CALIBRATED LED should be on.
- Press RESET.
- Remove the 100-kΩ resistor and wait for 12 seconds.  
**PASS:** The SE-330 should trip on resistor fault.

**NOTE:** Resistor-fault-trip reset can take up to one second.



### 9.1.2 VOLTAGE TEST

Test Equipment: 0 to 120 Vac voltage source and multimeter.

**NOTE:** Applying the test voltage to the R and G terminals will damage the SE-330 and the ER sensing resistor. The  $V_N$  TRIP LEVEL is the trip voltage at terminal N, not terminal R.

Procedure:

- Check the ER sensing resistor connection to the SE-330.
  - Disconnect the wire from sensing-resistor terminal N.
  - Set the voltage source to 0 V.
  - Connect the voltage source between sensing resistor N and G terminals.
  - Set the  $V_N$  TRIP LEVEL (VAC) to 20.
  - Press RESET.
  - The RESISTOR FAULT TRIP LED should be off.
  - Increase the test voltage to 25 Vac for 20-k $\Omega$  sensors or 120 Vac for 100-k $\Omega$  sensors and wait 12 seconds
- PASS:** The SE-330 should trip on RESISTOR FAULT. For units with firmware Revision 7 or higher, a time-delayed ground-fault trip follows the resistor-fault trip if neutral voltage persists after the resistor fault

### 9.2 SENSING-RESISTOR TEST

Test Equipment: Multimeter.

Procedure:

- Disconnect the sensing resistor.
- Measure the resistance between sensing-resistor terminals R and N.  
**PASS:** Resistance should be between 19.6 and 20.4 k $\Omega$  for 20-k $\Omega$  sensing resistors. Resistance should be between 98 and 102 k $\Omega$  for 100-k $\Omega$  sensing resistors.
- Measure the resistance between sensing-resistor terminals R and G in both directions.  
**PASS:** Resistance should be greater than 10 M $\Omega$  in both directions.

### 9.3 ANALOG-OUTPUT TEST

Test Equipment: Multimeter with a mA<sub>dc</sub> scale.

Procedure:

- Connect the 4–20-mA output as a self-powered output as shown in Fig. 3. Measure the current from terminal 20 to terminal 21.  
**PASS:** With no CT current, the analog output should be 4 mA.
- Output is linear to 20 mA. Output is 20 mA when CT-primary current is equal to the CT-primary rating.

### 9.4 GROUND-FAULT PERFORMANCE TEST

To meet the requirements of the National Electrical Code (NEC), as applicable, the overall ground-fault protection system requires a performance test when first installed. A written record of the performance test is to be retained by those in charge of the electrical installation in order to make it available to the authority having jurisdiction. A test-record form is provided for recording the date and the final results of the performance tests. The following ground-fault system tests are to be conducted by qualified personnel:

- a) Evaluate the interconnected system in accordance with the overall equipment manufacturer's detailed instructions.
- b) Verify proper location of the ground-fault current transformer. Ensure the cables pass through the ground-fault-current-transformer window. This check can be done visually with knowledge of the circuit. The connection of the current-transformer secondary to the SE-330 is not polarity sensitive.
- c) Verify that the system is correctly grounded and that alternate ground paths do not exist that bypass the current transformer. High-voltage testers and resistance bridges can be used to determine the existence of alternate ground paths.
- d) Verify proper reaction of the circuit-interrupting device in response to a simulated or controlled ground-fault current. To simulate ground-fault current, use CT-primary current injection. Fig. 17a shows a test circuit using a Startco SE-400 Ground-Fault-Relay Test Unit. The SE-400 has a programmable output of 0.5 to 9.9 A for a duration of 0.1 to 9.9 seconds. Set the test current to 120% of GF TRIP LEVEL. Fig. 17b shows a test circuit using a Startco SE-100T Ground-Fault-Relay Tester. The SE-100T provides a test current of 0.65 or 2.75 A for testing 0.5- and 2.0-A trip levels. Inject the test current through the current-transformer window for at least 2.5 seconds. Verify that the circuit under test has reacted properly. Correct any problems and re-test until the proper reaction is verified.
- e) Record the date and the results of the test on the attached test-record form.

**NOTE:** Do not inject test current directly into CT-input terminals 8, 9, 10, and 11.

