

SE-145 MANUAL

GROUND-FAULT GROUND-CHECK MONITOR

September 16, 2008

PRELIMINARY

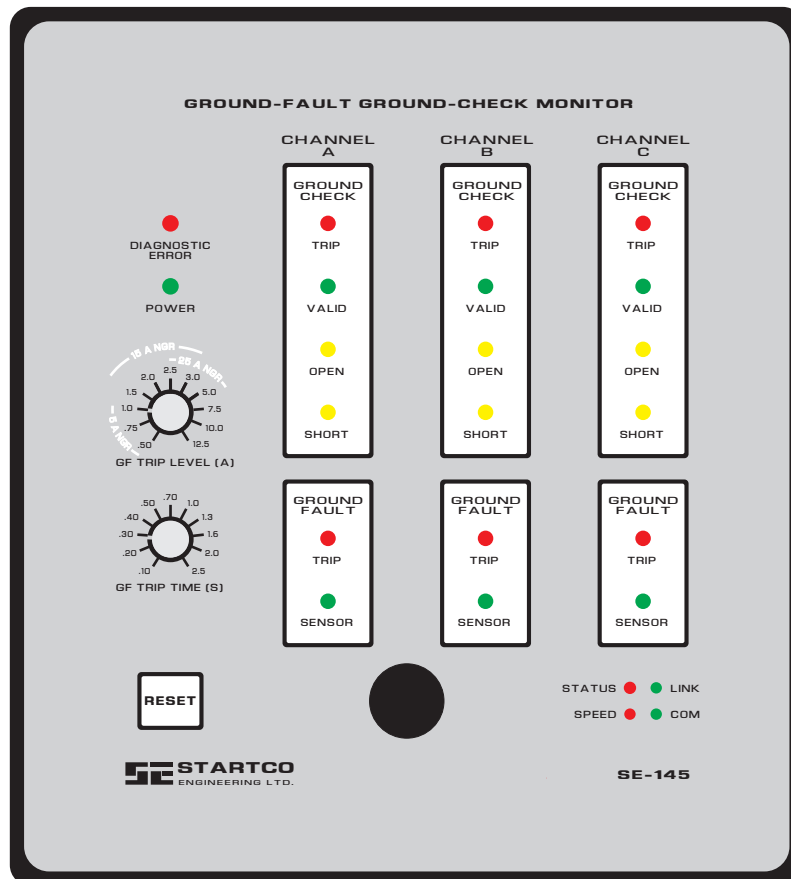

Copyright © 2008 by Startco Engineering Ltd.

All rights reserved.

This page intentionally left blank.



TABLE OF CONTENTS

	PAGE
Table of Contents	i
List of Figures	i
List of Tables.....	i
1. General	1
2. Operation.....	1
2.1 Configuration Settings.....	1
2.1.1 Trip-Relay Mode (S1).....	1
2.1.2 Ground-Check-Trip (S2)	1
2.1.3 Sensor Verify (S3).....	1
2.1.4 Remote Power-Up (S4).....	1
2.2 Ground-Fault Circuits.....	2
2.3 Ground-Check Circuits.....	2
2.4 Reset	2
2.5 Trip Relays	2
2.6 Network Communications	2
3. Indication.....	3
3.1 Ground Fault.....	3
3.2 Ground Check.....	3
3.3 Power.....	3
3.4 Diagnostic Error	3
4. Installation.....	3
4.1 General	3
4.2 Monitor	3
4.3 Current Sensors.....	5
4.4 Termination Assembly.....	5
4.5 Isolated-Ground Applications.....	5
5. Technical Specifications	9
6. Ordering Information	10
7. Warranty	10

LIST OF FIGURES

FIGURE		PAGE
1.	Configuration Switches	1
2.	SE-145 Connection Diagram.....	4
3.	Fail-Safe Trip-Relay Connection	5
4.	Non-Fail-Safe Trip-Relay Connection	5
5.	SE-145 Outline and Mounting Details	6
6.	SE-CS10 Current Sensors	7
7.	SE-TA12A Termination Assembly	8

LIST OF TABLES

TABLE		PAGE
1.	Coil Address.....	3
2.	Holding Register Address	3

DISCLAIMER

Specifications are subject to change without notice. Startco Engineering Ltd. is not liable for contingent or consequential damages, or for expenses sustained as a result of incorrect application, incorrect adjustment, or a malfunction.



This page intentionally left blank.



1. GENERAL

The SE-145 is a three-channel microprocessor-based, combination ground-fault and ground-check monitor for resistance-grounded systems. It has a switching power supply that accepts a wide range of ac and dc voltages, and its specifications apply over an industrial temperature range at high humidity. The operating conditions of each channel are clearly indicated by LED's and two Form C contacts are provided for remote indication of ground-fault and ground-check status. Isolated, normally open and normally closed contacts are provided for contactor control or for shunt or undervoltage operation in a breaker-trip circuit. The SE-145 is housed in an anodized extruded-aluminum enclosure, and all connections are made with plug-in, wire-clamping terminal blocks.

The ground-fault circuits detect fundamental-frequency, zero-sequence current with a window-type current sensor and verify that the current sensor is connected and not shorted. A definite-time characteristic with 11 trip levels and 11 trip times allows coordination in virtually any resistance-grounded system. Although other current sensors may satisfy the verification circuit, only SE-CS10's have characteristics that meet system specifications. Current-sensor verification can be disabled in a ground-check-only application.

The ground-check circuits have an open-circuit voltage of 30 Vdc so it is not a hazard to personnel, and have an output drive current above 100 mA for optimum performance in slip-ring, commutated-load, and high-induced-ac applications.

Each of the three ground-check circuits feature an externally accessible ground-check fuse, 3-kV ground-check loop isolation, and optional network communications circuits.

Unlike ground-check circuits using other termination devices, and especially those with phase-reversal switches, a ground-check circuit using a termination device with a Zener characteristic is capable of loop measurements that are independent of current in the phase conductors. The SE-145 ground-check circuits recognize the SE-TA12A 12-volt Zener characteristic as a valid end-of-line completion. This is the only passive characteristic that will satisfy the ground-check circuit's multi-level drive, allow induced currents to circulate in the ground-check loop, survive a phase-to-ground-check fault, and clamp the ground-check voltage during the fault. Although a standard 12-volt Zener diode may engage the SE-145's ground-check circuit, only an SE-TA12A has the accuracy and temperature compensation required to meet system specifications.

2. OPERATION

2.1 CONFIGURATION SETTINGS

Four configuration switches (S1 to S4) are located behind the access cover on the front panel. See Figs. 1 and 5.

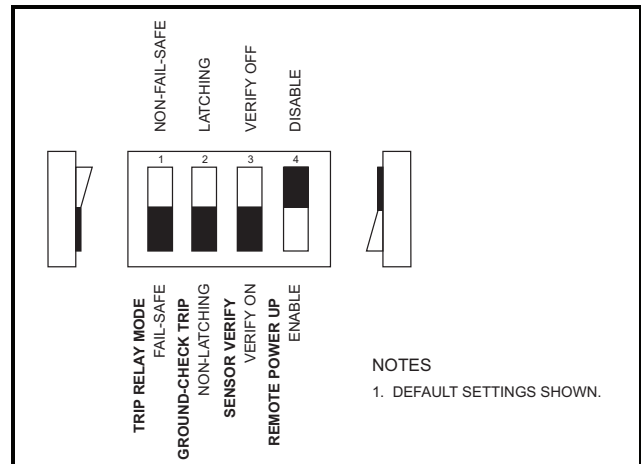

FIGURE 1. Configuration Switches.

2.1.1 TRIP-RELAY MODE (S1)

Set switch S1 to select the operating mode of the trip relays. In the non-fail-safe mode the trip relays are energized and their normally open contacts close when a trip occurs. The non-fail-safe mode can be used to trip shunt-trip circuit breakers.

In the fail-safe mode the trip relays are energized and their normally open contacts are closed when there are no trips. Trip relays de-energize and their normally open contacts open if there is a trip, a loss of supply voltage or a processor failure. See Section 2.5.

2.1.2 GROUND-CHECK-TRIP (S2)

Set switch S2 to select latching or non-latching ground-check circuit operation. See Section 2.3.

2.1.3 SENSOR VERIFY (S3)

Set switch S3 to select current sensor verification. See Section 2.3.

2.1.4 REMOTE Power-UP (S4)

Set switch S4 to allow a network communications command to power up the SE-145.

NOTE: This function is available only on units with the 24-Vdc battery back-up (Option 3) power supply.

In the DISABLE mode, the SE-145 remains powered even when a power-down command is issued by network communications. See Section 2.6.



2.2 GROUND-FAULT CIRCUITS

The ground-fault circuits have a definite-time characteristic with 11 settings from 0.1 to 2.5 seconds. Time-coordinated ground-fault protection requires the trip time to be longer than the trip time of downstream ground-fault devices. The trip level of the ground-fault circuit is switch selectable with 11 settings from 0.5 to 12.5 A. A minimum tripping ratio of 5 is recommended to achieve at least 80% winding protection, and requires the trip level to be less than 20% of the grounding resistor let-through current. Suggested trip-level ranges for 5-A, 15-A, and 25-A neutral-grounding resistors are indicated on the faceplate.

2.3 GROUND-CHECK CIRCUITS

Each ground-check circuit is protected by a 1.5-A time-delay fuse, and it recognizes an SE-TA12A as a valid end-of-line completion.

The ground-check circuits are usually operated in the non-latching mode; however, they can be operated in the latching mode by setting configuration switch S2 to LATCHING. If the SE-145 is operated in a ground-check-only application and SE-CS10 sensors are not connected, set configuration switch S3 to VERIFY OFF.

2.4 RESET

Ground-fault trips are latching and ground-check trips can be latching or non latching. See Section 2.1.2. A trip remains latched until the RESET switch is pressed or the remote-reset terminals are momentarily connected. Cycling the supply voltage will also reset ground-fault trips; however, if the ground-check circuit is configured for latching fail-safe operation, the ground-check circuit will trip when supply voltage is applied. The reset circuit responds only to a momentary closure so that a jam or shorted switch will not maintain a reset signal.

A reset can also be issued using network communications.

2.5 TRIP RELAYS

Isolated, normally open and normally closed contacts are provided for use in contactor- or breaker-control circuits. Configuration switch S1 allows the trip relays to operate in either fail-safe or non-fail-safe mode. See Sections 2.1.1 and 4.2. The fail-safe mode is used with undervoltage devices where the trip relay energizes and its normally open contacts close if the ground-fault and ground-check circuits are not tripped. This mode is recommended because:

- Undervoltage devices release if supply voltage fails.
- Undervoltage ground-check circuits do not allow cable couplers to be energized until the ground-check loop is verified.

The fail-safe mode of operation of the SE-145 trip relay can be used for shunt-trip circuits with a stored-energy trip source. In this case, the normally closed trip contacts are used—the contacts open when the SE-145 is energized and the ground-fault and ground-check circuits are not tripped. Care must be taken to ensure safe and correct operation during power up and power down.

Non-fail-safe trip relay operation can be selected with shunt-trip devices. In this mode, the normally open trip contact is used—the trip contacts are closed when a ground-fault or ground-check trip is indicated on the SE-145.

Shunt-trip circuits are not fail-safe and are not recommended because:

- Shunt-trip devices do not operate if supply voltage fails.
- Shunt-trip ground-check circuits allow open cable couplers to be energized for a short interval after supply voltage is applied.

2.6 NETWORK COMMUNICATIONS

The network communications available at this time is IEEE 802.3 (Ethernet) with Modbus TCP protocol.

The SE-145 default IP address is 10.0.0.1. Use SE-MON145 available at www.startco.ca to change the IP address, to monitor connected SE-145's, and to issue remote commands. Add SE-MON145 to the Windows Firewall Exceptions list in the Windows Control Panel, to allow SE-145's to be added to the network.

On start-up SE-MON145 scans the network for SE-145's. To change the IP address, subnet mask, or description of an SE-145: first select the SE-145 from the list and then click "Edit". The new IP address should be one that is free and available on the local area network, then "Apply" the changes. SE-MON145 will pause for 5 seconds and then rescan the network. To view the status of an SE-145, select the unit and click "Monitor". If a warning appears, the SE-145 may have been set to an address that is not accessible by the network.

Table 1 shows the coil addresses for the SE-145. Table 2 provides the holding registers in 16-bit format.

A remote reset can be generated by writing DO1 high for one second and then writing it back to low.

A power up is accomplished by writing DO2 high and a power down is accomplished by writing DO2 low.



TABLE 1 COIL ADDRESS

COIL ADDRESS	DESCRIPTION	NAME	ATTRIBUTE
00001	Channel A GC Status	DI0	Read
00002	Channel A GF Status	DI1	Read
00003	Channel A Trip Relay	DI2	Read
00004	Channel B GC Status	DI3	Read
00005	Channel B GF Status	DI4	Read
00006	Channel B Trip Relay	DI5	Read
00007	Channel C GC Status	DI6	Read
00008	Channel C GF Status	DI7	Read
00009	Channel C Trip Relay	DI8	Read
00010	Not used		
00011	Power-Up Status	DI10	Read
00012	Not used		
00013	Not used		
00014	Not used		
00015	Not used		
00016	Not used		
00017	Not used		
00018	Remote Reset	DO1	Read/Write
00019	Power-Up Status	DO2	Read/Write
00020	Not used		
00021	Not used		
00022	Not used		

TABLE 2 HOLDING REGISTER ADDRESS

REGISTER ADDRESS	DESCRIPTION	ATTRIBUTE
40301	DI0 – DI11	Read
40303	DO0 – DO5	ReadWrite

3. INDICATION

3.1 GROUND FAULT

Red Ground-Fault Trip LED's indicate a ground-fault trip. The corresponding GF remote-indication relay is energized when the ground-fault circuit is not tripped. When current sensor verification is on, a green LED indicates the applicable current sensor is correctly connected. If the current sensor is disconnected or shorted, the corresponding green LED will be off and the ground-fault circuit will trip. If the sensor fault is intermittent, the ground-fault circuit will trip and the green LED will flash indicating that the trip was initiated by a sensor fault.

3.2 GROUND CHECK

Red Ground-Check Trip LED's indicate a ground-check trip. A green LED indicates a valid ground-check loop and the corresponding GC remote-indication relay is energized when the ground-check loop is valid. Yellow LED's indicate an invalid ground-check loop. OPEN indicates the loop resistance exceeds the trip resistance and SHORT indicates the ground-check conductor is shorted to the ground conductor. A flashing yellow LED indicates the cause of a latched ground-check trip.

3.3 POWER

This green LED indicates that the internal power supply is on.

3.4 DIAGNOSTIC ERROR

This red LED indicates that an internal error caused the SE-145 to trip. Return the SE-145 to the factory if a reset or cycling power does not clear the error.

4. INSTALLATION

4.1 GENERAL

This ground-fault ground-check monitoring system consists of an SE-145 Monitor, three SE-CS10 Current Sensors, and three SE-TA12A Termination Assemblies connected as shown in Fig. 2.

4.2 MONITOR

Outline and Mounting Details for the SE-145 are shown in Fig. 5. To panel mount the SE-145, insert it through the panel cutout and secure it with six 8-32 locknuts and flat washers.

The SE-145 wire-clamping terminal blocks accept 24 to 12 AWG (0.2 to 2.5 mm) conductors. These terminal blocks unplug to allow the SE-145 to be easily removed.

Connect supply voltage to terminals 1 and 2 (L1 and L2/N) as shown in Fig. 2. In 120-Vac systems, L2/N is designated as the neutral conductor. For direct-current power supplies, use L1 for the positive terminal and L2/N as the negative terminal. Ground terminal 3 (\oplus).

The 24-Vdc battery back-up configuration, (power supply Option 3) requires the SE-145 to be powered from a battery back-up 24-Vdc power supply.

CAUTION: When using the battery back-up configuration a 24-V battery must be connected across terminals 1 and 2 at all times. Battery voltage must be between 18 Vdc and 30 Vdc or the SE-145 may be damaged.

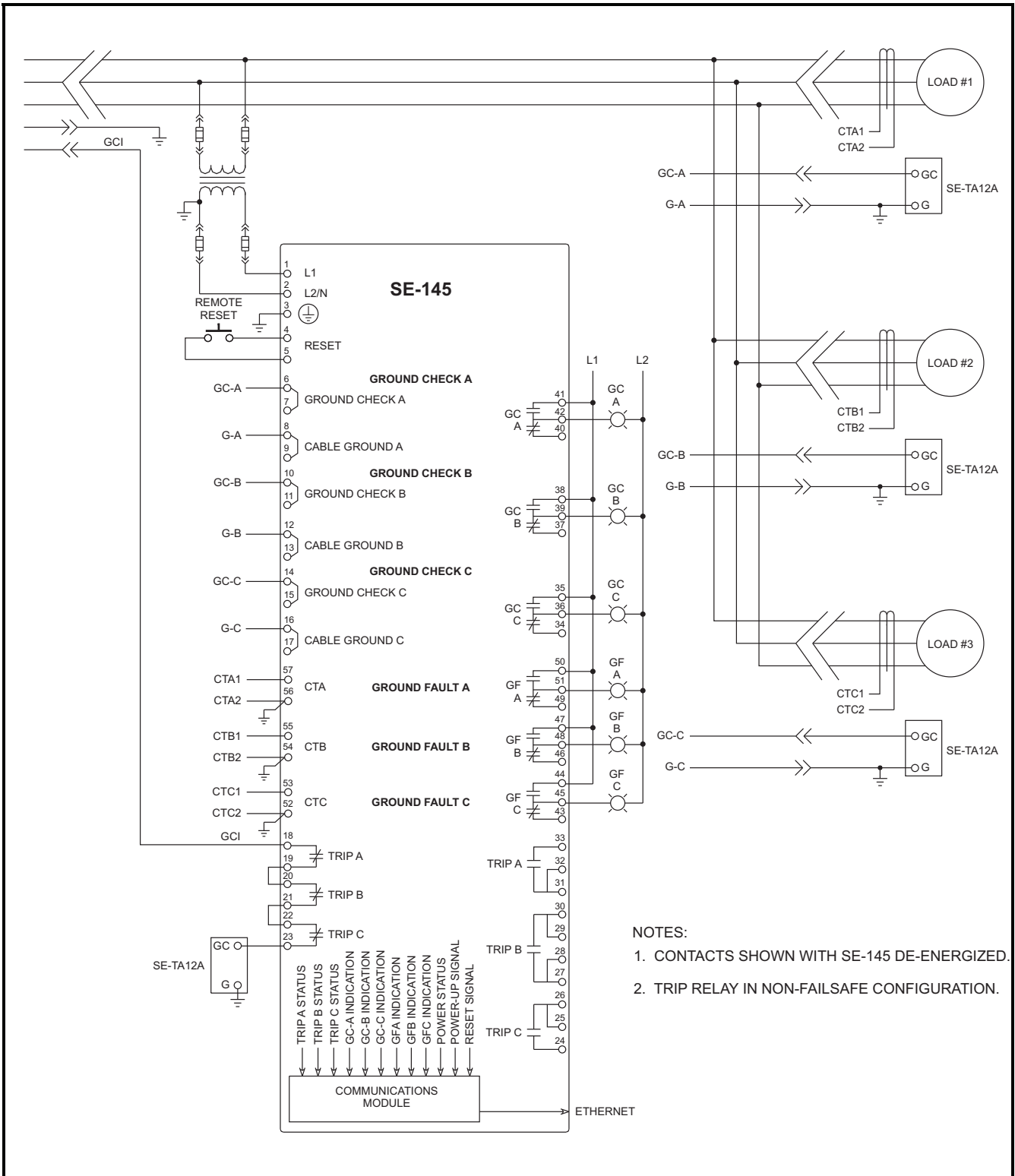

FIGURE 2. SE-145 Connection Diagram.



For fail-safe trip relay operation with undervoltage devices connect the normally open trip relay contacts as shown in Fig. 3.

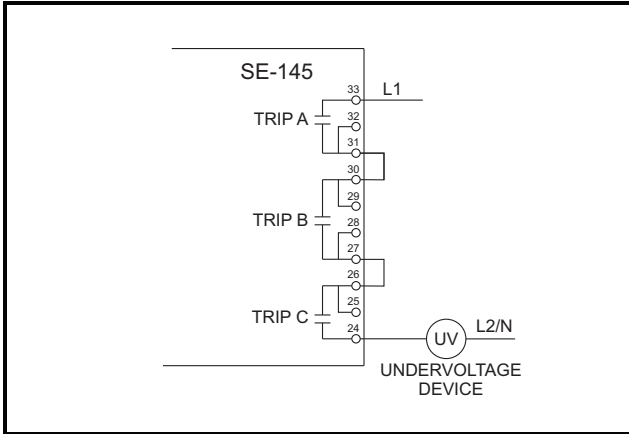

FIGURE 3. Fail-Safe Trip-Relay Connection.

For non-fail-safe trip relay operation with shunt-trip devices connect the normally open trip relay contacts as shown in Fig. 4.

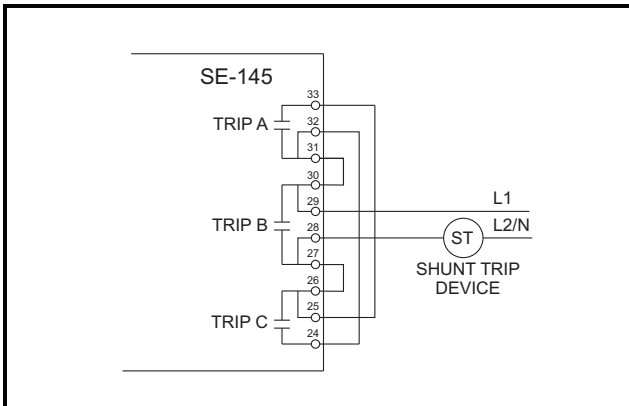

FIGURE 4. Non-Fail-Safe Trip-Relay Connection.

4.3 CURRENT SENSORS

Outline dimensions and mounting details for the SE-CS10's are shown in Fig. 6. Pass only phase conductors through the sensor window as shown in Fig. 2. If a shield, ground, or ground-check conductor enters the sensor window, it must be returned through the window before it is terminated. Connect the current sensor A to terminals 56 and 57, connect current sensor B to terminals 54 and 55 and current sensor C to terminals 52 and 53. Ground terminals 52, 54 and 56.

4.4 TERMINATION ASSEMBLY

Outline dimensions and mounting details for the SE-TA12A are shown in Fig. 7. Install the SE-TA12A at the load to complete the ground-check loop as shown in Fig. 2. Connect terminal G of the SE-TA12A to the equipment frame so that the ground-conductor-to-equipment-frame connection will be included in the monitored loop.

4.5 ISOLATED-GROUND APPLICATIONS

Each of the three ground-check circuits have 3-kV isolation between the ground-check loop and monitor electronics. This allows the SE-145 to be applied on isolated, non-isolated and mixed systems.

In a typical non-isolated-ground application, terminals 8, 9, 12, 13, 16, and 17 are connected to local substation ground. In isolated-ground applications, terminal pairs (8, 9), (12, 13), and (16, 17) are isolated and not connected to local substation ground, but referenced to remote ground. It is also possible to apply the SE-145 on a system consisting of a mixture of isolated and non-isolated ground-check loops.

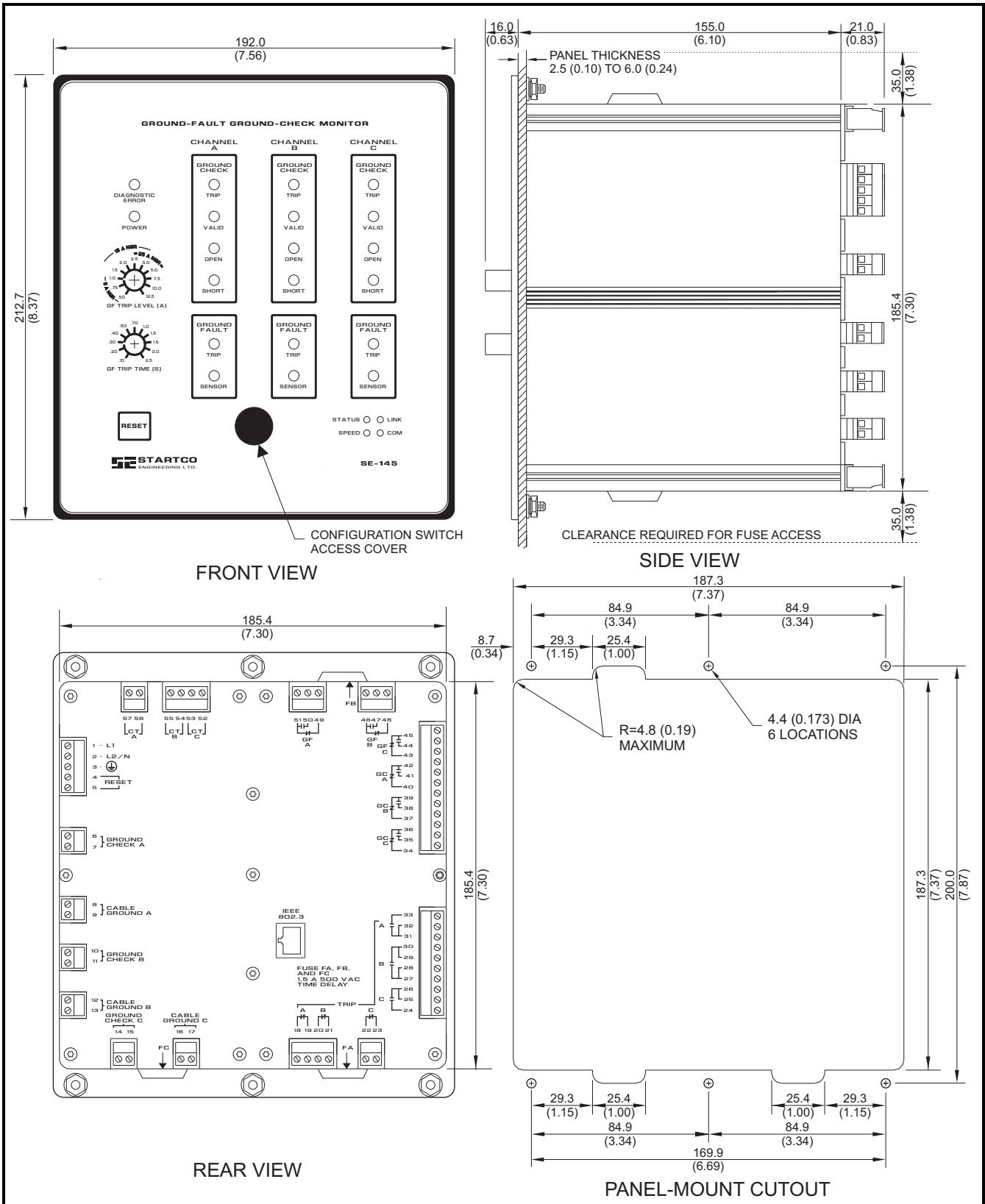

FIGURE 5. SE-145 Outline and Mounting Details.

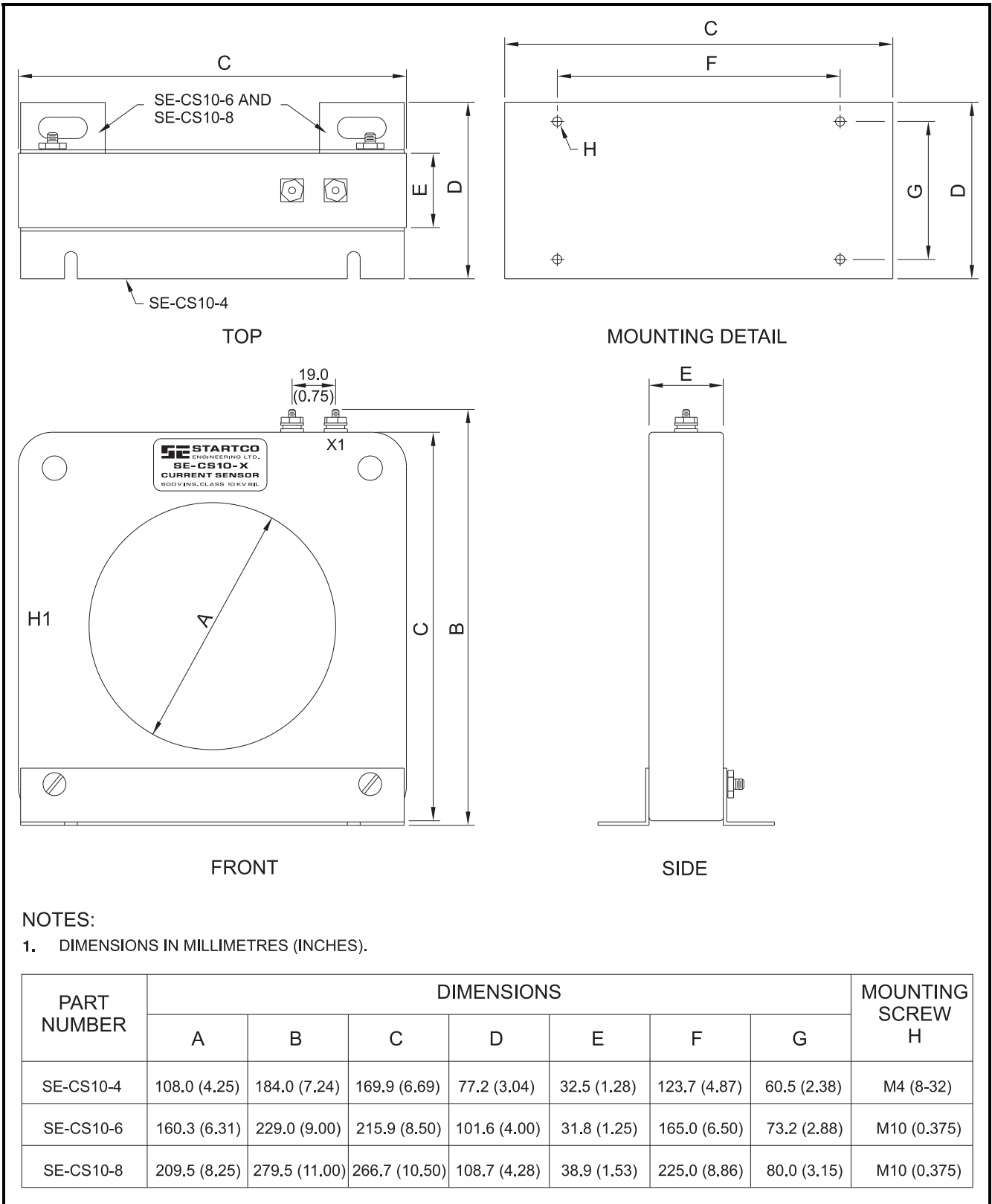

FIGURE 6. SE-CS10 Current Sensors.

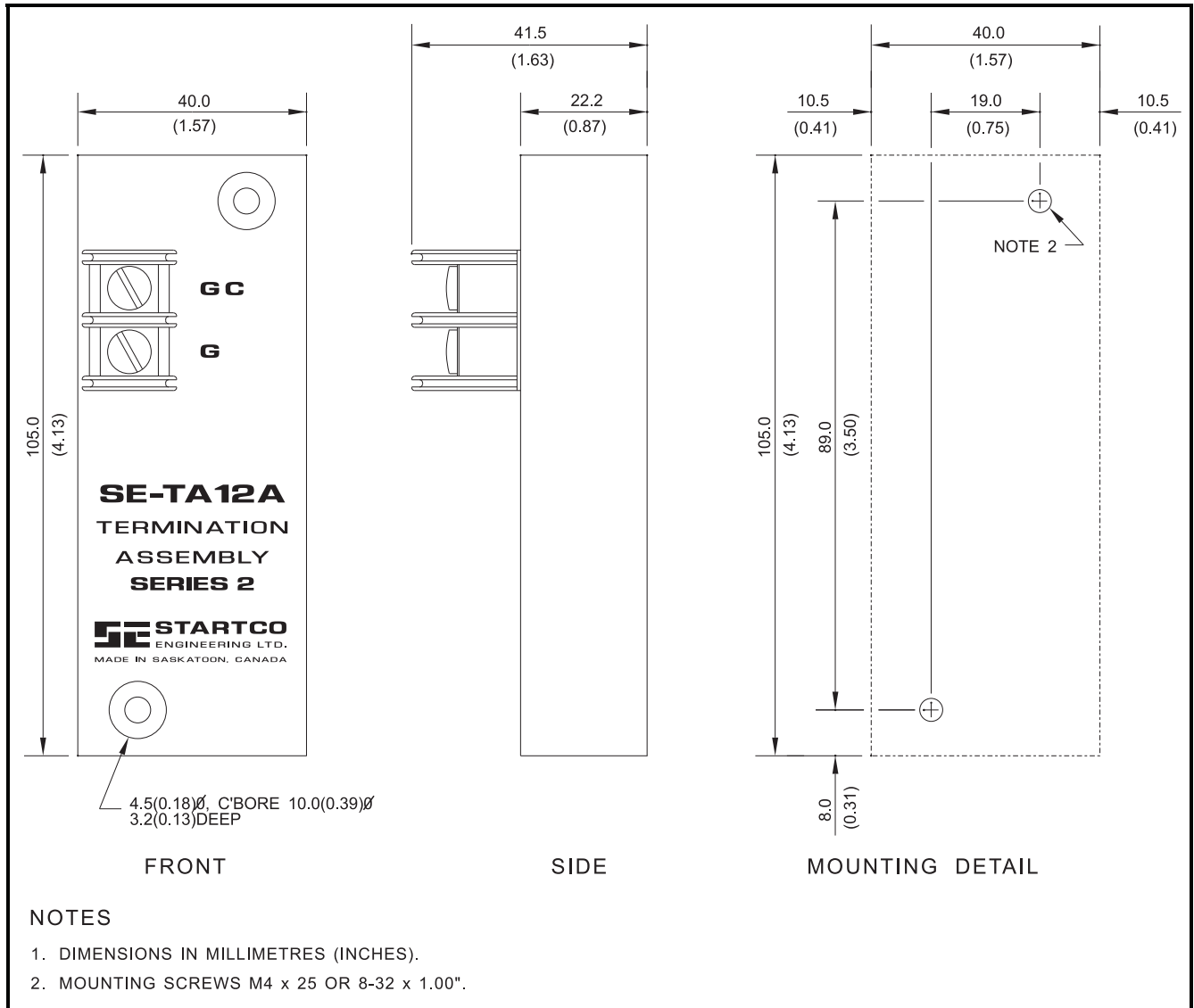

FIGURE 7. SE-TA12A Termination Assembly.



5. TECHNICAL SPECIFICATIONS

Power Supply:

Option 0	120-240 Vac (+10, -50%), 60VA, 50-400 Hz. 110-250 Vdc (+10, -25%), 45 W.
Option 3	24-Vdc ($\pm 25\%$), 45 W Battery Back-up

Ground-Fault Circuits:

Digital Filter	50 to 60 Hz, Bandpass
Trip-Level Settings	0.5, 0.75, 1.0, 1.5, 2.0, 2.5, 3.0, 5.0, 7.5, 10.0, and 12.5 A
Trip-Time Settings	0.1, 0.2, 0.3, 0.4, 0.5, 0.7, 1.0, 1.3, 1.6, 2.0, and 2.5 s
Thermal Withstand	150 A Continuous 1000 A for 2.5 s (Ground-Fault Current)
Trip-Level Accuracy	$\pm 5\%$ or 0.1 A
Trip-Time Accuracy	+50, -15 ms
Sensor Verification	Enabled or Disabled
Operating Mode	Latching

Ground-Check Circuits:

Open-Circuit Voltage	30 Vdc
Output Impedance	136 Ω
Loop Current	105 mA
Pull-in Time	≤ 1.5 s
Trip Time @ 50 Ω	220 \pm 30 ms
GC-Loop Trip Resistance	28 \pm 5 Ω
Isolation	3 kV, 60 Hz, 1 s
Test	Front-Panel Switch and Remote, N.O. Contact
Fuse Rating (F1)	1.5 A, 500 Vac, Time Delay
Fuse Part Number	FNQ 1½ Buss Fusetron
Operating Mode	Latching or Non-Latching

Trip Relays:

CSA/UL Contact Rating	8 A Resistive 250 Vac,
Supplemental Contact Ratings:	
Make/Carry (0.2 s)	30 A
Break dc	75 W Resistive, 35 W Inductive (L/R < 0.04)
Break ac	2000 VA Resistive, 1500 VA Inductive (PF > 0.4)
Subject to maximums of 8 A and 250 V (ac or dc)	
Contact Configuration	Isolated N.O. and N.C. Contacts
Operating Mode	Fail-Safe or Non-Fail-Safe

Remote-Indication Relays:

CSA/UL Contact Rating	8 A Resistive 250 Vac,
Supplemental Contact Ratings:	
Make/Carry (0.2 s)	20 A
Break dc	50 W Resistive, 25 W Inductive (L/R < 0.04)
Break ac	2000 VA Resistive, 1500 VA Inductive (PF > 0.4)
Subject to maximums of 8 A and 250 V (ac or dc)	
Contact Configuration	Form C
Operating Mode	Fail-Safe

Terminal Block Rating

Dimensions (Panel Mount):

Height	213 mm (8.4")
Width	192 mm (7.6")
Depth:	
Behind Panel	176 mm (7.0")
In Front of Panel	16 mm (0.7")

Environment:

Operating Temperature	-40°C to 60°C
Storage Temperature	-55°C to 80°C
Humidity	85% Non Condensing



6. ORDERING INFORMATION

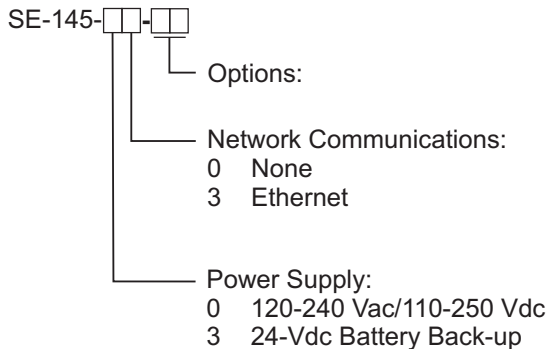

SE-TA12A Termination Assembly

SE-CS10-4 Current Sensor, 108 mm (4.2") Window

SE-CS10-6 Current Sensor, 160 mm (6.3") Window

SE-CS10-8 Current Sensor, 209 mm (8.2") Window

7. WARRANTY

The SE-145 Ground-Fault Ground-Check Monitor is warranted to be free from defects in material and workmanship for a period of five years from the date of purchase.

Startco Engineering Ltd. will (at Startco's option) repair, replace, or refund the original purchase price of an SE-145 that is determined by Startco to be defective if it is returned to the Startco factory, freight prepaid, within the warranty period. This warranty does not apply to repairs required as a result of misuse, negligence, an accident, improper installation, tampering, or insufficient care. Startco Engineering Ltd. does not warrant products repaired or modified by non-Startco Engineering Ltd. personnel.

Startco Engineering Ltd. is not liable for contingent or consequential damages; for expenses sustained as a result of incorrect application, incorrect adjustment, or a malfunction; or for expenses resulting from the use of, or inability to use, the product.