

## SE-134C MANUAL

### GROUND-FAULT GROUND-CHECK MONITOR

APRIL 7, 2009

REVISION 4

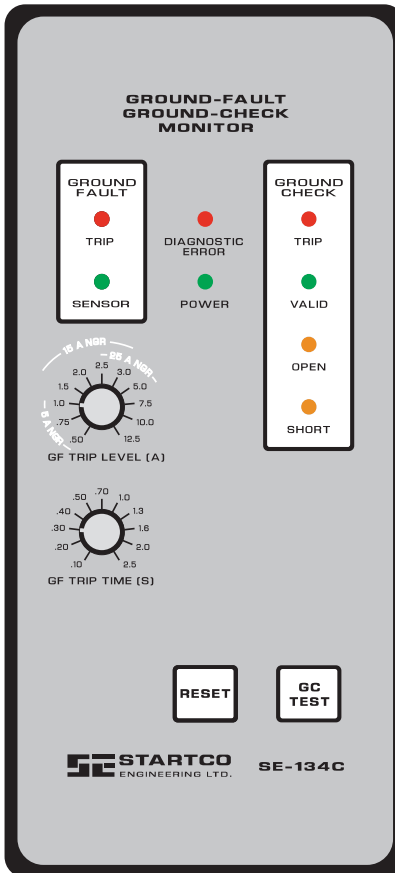

Copyright © 2009 by Littelfuse Startco.

All rights reserved.

Blank Page

## TABLE OF CONTENTS

	PAGE
Table of Contents .....	i
List of Figures .....	i
<b>1. General</b> .....	<b>1</b>
<b>2. Operation</b> .....	<b>1</b>
2.1 Ground-Fault Circuit .....	1
2.1.1 GF Trip Time Setting .....	1
2.1.2 GF Trip Level Setting .....	1
2.2 Ground-Check Circuit .....	1
2.3 Reset .....	2
2.4 Trip Relay .....	2
<b>3. Indication</b> .....	<b>2</b>
3.1 Ground Fault .....	2
3.2 Ground Check .....	2
3.3 Power .....	2
3.4 Diagnostic Error .....	2
<b>4. Installation</b> .....	<b>2</b>
4.1 General .....	2
4.2 Monitor .....	3
4.3 Current Sensors .....	3
4.4 Termination Assembly .....	3
4.5 Remote Operation .....	3
4.6 Parallel-Path Isolation .....	3
<b>5. Technical Specifications</b> .....	<b>12</b>
5.1 SE-134C .....	12
5.2 Current Sensors .....	13
5.3 Termination Assemblies .....	13
<b>6. Ordering Information</b> .....	<b>13</b>
<b>7. Warranty</b> .....	<b>14</b>
<b>8. Test Procedures</b> .....	<b>14</b>
8.1 Ground-Check Trip Tests .....	14
8.1.1 Latching Ground-Check Trip Test .....	14
8.1.2 Non-Latching Ground-Check Trip Test .....	14
8.2 Trip Relay Fail-Safe Mode Test .....	14
8.3 Current Sensor Verification Test .....	14
8.4 SE-TA6A-Series Termination Assembly Tests .....	15
8.5 Ground-Fault Performance Test .....	15

## LIST OF FIGURES

FIGURE		PAGE
1	SE-134C Typical Application .....	4
2	SE-134C Outline and Panel-Mounting Details .....	5
3	SE-134C Outline and Surface-Mounting Details .....	6
4	SE-CS10 Current Sensors .....	7
5	SE-TA6A and SE-TA6A-WL Termination Assemblies .....	8
6	SE-TA6ASF-WL Small-Format Termination Assembly .....	9
7	RK-132 Remote Indication and Reset .....	9
8	PPI-600V Parallel-Path Isolator .....	10
9	PPI-600V Typical Application .....	11
10	Ground-Fault-Test Circuit .....	16
11	Termination-Assembly-Test Circuits .....	16

## LIST OF TABLES

TABLE		PAGE
1	Ground-Fault-Test Record .....	15

## DISCLAIMER

Specifications are subject to change without notice. Littelfuse Startco is not liable for contingent or consequential damages, or for expenses sustained as a result of incorrect application, incorrect adjustment, or a malfunction.

Blank Page

## 1. GENERAL

The SE-134C is a microprocessor-based, combination ground-fault and ground-wire monitor for resistance-grounded systems. It has a switching power supply that accepts a wide range of ac and dc voltages, its specifications apply over an industrial temperature range at high humidity, and it meets the IEEE surge-withstand-capability tests (oscillatory and fast transient) for protective relays and relay systems. Isolated, normally open and normally closed contacts are provided for contactor control or for shunt or undervoltage operation in a breaker-trip circuit. All operating conditions are clearly annunciated and two Form C contacts are provided for remote indication. The SE-134C is housed in an anodized extruded-aluminum enclosure, and all connections are made with plug-in, wire-clamping terminal blocks. Provision is made for both panel and surface mounting.

The ground-fault circuit detects fundamental-frequency, zero-sequence current with a window-type current sensor and it verifies that the current sensor is connected and not shorted. A definite-time characteristic with 11 trip levels and 11 trip times allows coordination in virtually any resistance-grounded system. Although other current sensors may satisfy the verification circuit, only SE-CS10-series sensors have characteristics that meet system specifications. Current-sensor verification can be disabled for a ground-check-only application.

The ground-check circuit has an open-circuit voltage of 24 Vdc, which is not a hazard to personnel, and it has an output drive current above 100 mA for optimum performance in slip-ring, commutated-load, and high-induced-ac applications. Features include an externally accessible ground-check fuse, a resistance-insertion test, 3-kV isolation between the ground-check loop and the monitor electronics, and a PPI-600V accessory for parallel-ground-path rejection. A PPI-600V will also eliminate intermachine arcing and prevent stray ac and dc currents from flowing in the monitored ground wire. Unlike ground-check circuits using other termination devices, and especially those with phase-reversal switches, a ground-check circuit using a termination device with a Zener characteristic is capable of loop measurements that are independent of current in the phase conductors. The SE-134C ground-check circuit recognizes the SE-TA6A-series 5.6-volt Zener characteristic as a valid end-of-line completion. This is the only passive characteristic that will satisfy the ground-check circuit's multi-level drive, allow induced currents to circulate in the ground-check loop, survive a phase-to-ground-check fault, and clamp the ground-check voltage during the fault. Although a standard 5.6-volt Zener diode may engage the SE-134C's ground-check circuit, only an SE-TA6A-series termination assembly has the compensation required to meet system specifications. In

select applications, a combination of an SE-TA12A and SE-TA12B Termination Assemblies can be used to monitor the cables of a splitter box (junction box) using a single SE-134C Monitor. See Technical Information 6.3, available at [www.startco.ca](http://www.startco.ca).

## 2. OPERATION

### 2.1 GROUND-FAULT CIRCUIT

#### 2.1.1 GF TRIP TIME SETTING

The ground-fault circuit has a definite-time characteristic with 11 settings from 0.1 to 2.5 seconds. Time-coordinated ground-fault protection requires the trip time to be longer than the trip time of downstream ground-fault devices.

#### 2.1.2 GF TRIP LEVEL SETTING

The trip level of the ground-fault circuit is switch selectable with 11 settings from 0.5 to 12.5 A. A minimum tripping ratio of 5 is recommended to achieve at least 80% winding protection, and this requires the trip level to be less than 20% of the grounding resistor let-through current. Suggested trip-level ranges for 5-, 15-, and 25-A neutral-grounding resistors are indicated on the faceplate. A ground-fault trip is latched, requiring a reset. A current-sensor failure will also cause a ground-fault trip. See Section 3.1

If the SE-134C is operated in a ground-check-only application and an SE-CS10 is not connected, connect terminals 17 and 18 to disable sensor verification. See Fig. 1.

### 2.2 GROUND-CHECK CIRCUIT

The ground-check loop consists of the outgoing ground-check conductor, quick-coupler connections, the SE-TA6A-series termination assembly, the SE-TA6A connection to equipment frame or ground bus, the ground-return path, and the SE-134C cable-ground-terminal connection to substation ground.

The SE-134C detects a valid ground-check loop when an SE-TA6A-series termination assembly is detected in the loop and loop resistance is less than 28 ohms. The loop is not valid if open (or high resistance), or if the ground-check conductor is shorted to ground.

When the ground-check loop is valid, the SE-134C ground-check circuit can be tested by pressing the GC TEST switch or by shorting GC TEST terminals 11 and 12. This test invalidates the loop by inserting 47  $\Omega$  in the ground-check loop and a trip should occur in less than 250 ms.

The ground-check circuit is usually operated in the non-latching mode; however, it can be operated in the latching mode by connecting terminals 14 and 15.

The ground-check circuit is protected by a 1.5-A time-delay fuse (F1).

If the SE-134C is used in a ground-fault-only application, an SE-TA6A must be connected to the ground-check and cable-ground terminals to validate the ground-check circuit. See Fig. 1.

### 2.3 RESET

All ground-fault trips are latching and ground-check trips can be latching or non-latching. To reset ground-fault trips or latching ground-check trips, press the RESET switch or short the RESET terminals 9 and 10. See Fig. 1.

Cycling the supply voltage will also reset ground-fault trips; however, if the ground-check circuit is configured for latching fail-safe operation, the ground-check circuit will trip when supply voltage is applied.

The single-shot reset circuit responds only to a momentary closure; a jammed or shorted switch will not maintain a reset signal.

### 2.4 TRIP RELAY

Isolated, normally open (Trip A, terminals 24 and 25) and normally closed (Trip B, terminals 22 and 23) contacts are provided for use in a contactor- or breaker-control circuit. With no connection between terminals 12 and 13, the SE-134C trip relay operates in the fail-safe mode. This mode is used with undervoltage devices where the trip relay energizes and its normally open contact closes if the ground-fault and ground-check circuits are not tripped. This mode is recommended because:

- Undervoltage devices release if supply voltage fails.
- Undervoltage ground-check circuits do not allow the power circuit and open cable couplers to be energized until the ground-check loop is verified.

The fail-safe mode of operation of the SE-134C trip relay can be used for shunt-trip circuits with a stored-energy trip source. In this case, the normally closed trip contact is used—the contact opens when the SE-134C is energized and the ground-fault and ground-check circuits are not tripped. Care must be taken to ensure safe and correct operation during power up and power down.

Connect terminals 12 and 13 for non-fail-safe trip relay operation with shunt-trip devices. In this mode, the normally open trip contact is used—the trip contact is closed when a ground-fault or ground-check trip occurs.

Shunt-trip circuits are not fail-safe and are not recommended because:

- Shunt-trip devices do not operate if supply voltage fails.
- Shunt-trip ground-check circuits allow the power circuit and open cable couplers to be energized for a short interval after supply voltage is applied.

**CAUTION:** The SE-134C is not a lock-out device. Follow lock-out procedures for maintenance.

## 3. INDICATION

### 3.1 GROUND FAULT

A red LED indicates a ground-fault trip and the remote-indication relay GF is energized when the ground-fault circuit is not tripped (fail-safe indication-contact operation). A green LED indicates a current sensor is correctly connected. If the SE-CS10-series current sensor is disconnected or shorted, the green LED will go out and the ground-fault circuit will trip. If the sensor fault is intermittent, the ground-fault circuit will trip and the green LED will flash to indicate that the trip was initiated by a sensor fault.

### 3.2 GROUND CHECK

A red LED indicates a ground-check trip. A green LED indicates a valid ground-check loop and the remote-indication relay GC is energized when the ground-check loop is valid (fail-safe indication-contact operation). Two yellow LED's indicate the status of an invalid ground-check loop. OPEN indicates the loop resistance exceeds the trip resistance and SHORT indicates the ground-check conductor is shorted to the ground conductor. A flashing yellow LED indicates the corrected cause of a latched ground-check trip.

### 3.3 POWER

The green POWER LED indicates that the internal power supply is on.

### 3.4 DIAGNOSTIC ERROR

The red DIAGNOSTIC ERROR LED indicates that an internal error caused the SE-134C to trip. Return the SE-134C to the factory if a reset does not clear the trip.

## 4. INSTALLATION

### 4.1 GENERAL

This ground-fault ground-check monitoring system consists of an SE-134C Monitor, an SE-CS10-series Current Sensor, and an SE-TA6A-series Termination Assembly connected as shown in Fig. 1. Select applications can use a combination of SE-TA12A and SE-TA12B Termination Assemblies. See Technical Information 6.3. If required, remote indication and reset can be with standard pilot devices, or with an RK-132 Remote-Indication-and-Reset Kit.

## 4.2 MONITOR

Each SE-134C is packaged with both panel- and surface-mounting hardware.

Outline and panel-cutout dimensions for the SE-134C are shown in Fig. 2. To panel mount the SE-134C, insert it through the panel cutout and secure it with the four supplied 8-32 locknuts and flat washers.

All connections to the SE-134C are made through plug-in, wire-clamping terminal blocks for 24 to 12 AWG (0.2 to 2.5 mm<sup>2</sup>) conductors. Each plug-in terminal block can be secured to the monitor by two captive screws for reliable connections in high-vibration applications.

Outline dimensions and mounting details for surface mounting an SE-134C are shown in Fig. 3. Fasten the surface-mount adapter to the mounting surface and make connections to the adapter terminal blocks. Follow the instructions on Fig. 3 to mount or remove the SE-134C.

The option -00 power supply operates from 60 to 265 Vac and 80 to 370 Vdc. The option -10 power supply operates from 24 to 48 Vdc. Use terminal 2 (L2/N) as the neutral terminal on ac systems or the negative terminal on dc systems.

**NOTE:** On revision 5 and newer units, terminal 3 (SPG) is internally connected to terminal 4. For these units an external terminal-3-to-terminal-4 connection is not required, nor is it necessary to remove the terminal-3 connection for dielectric-strength testing.

## 4.3 CURRENT SENSORS

Outline dimensions and mounting details for the SE-CS10-series current sensors are shown in Fig. 4. Pass only phase conductors through the sensor window as shown in Fig. 1. If a shield, ground, or ground-check conductor enters the sensor window, it must be returned through the window before it is terminated. Connect the current sensor to terminals 16 and 17. Ground terminal 17. Current-sensor primary and secondary connections are not polarity sensitive.

## 4.4 TERMINATION ASSEMBLY

Outline dimensions and mounting details for the SE-TA6A, SE-TA6A-WL, and SE-TA6ASF-WL are shown in Figs. 5 and 6. Install the SE-TA6A at the load to complete the ground-check loop as shown in Fig. 1. Connect terminal G of the SE-TA6A to the equipment frame so that the ground-conductor-to-equipment-frame connection will be included in the monitored loop.

## 4.5 REMOTE OPERATION

Remote indication contacts and a reset input are provided for remote indication and remote reset as shown in Fig. 1.

The optional 22-mm-component RK-132 Remote Kit is shown in Fig. 7. Connect terminals of the green ground-check indicator to SE-134C terminals 26 and 27 and the red ground-fault indicator to terminals 19 and 21. For remote reset, connect the normally open push-button switch across terminals 9 and 10.

## 4.6 PARALLEL-PATH ISOLATION

A PPI-600V can be used for parallel-path rejection. A PPI-600V will also eliminate inter-machine arcing and prevent stray ac and dc currents from flowing in the monitored ground wire. See Figs. 8 and 9. See Technical Information 9.6 “Parallel Path Isolator” at [www.startco.ca](http://www.startco.ca), or contact Startco for application details.

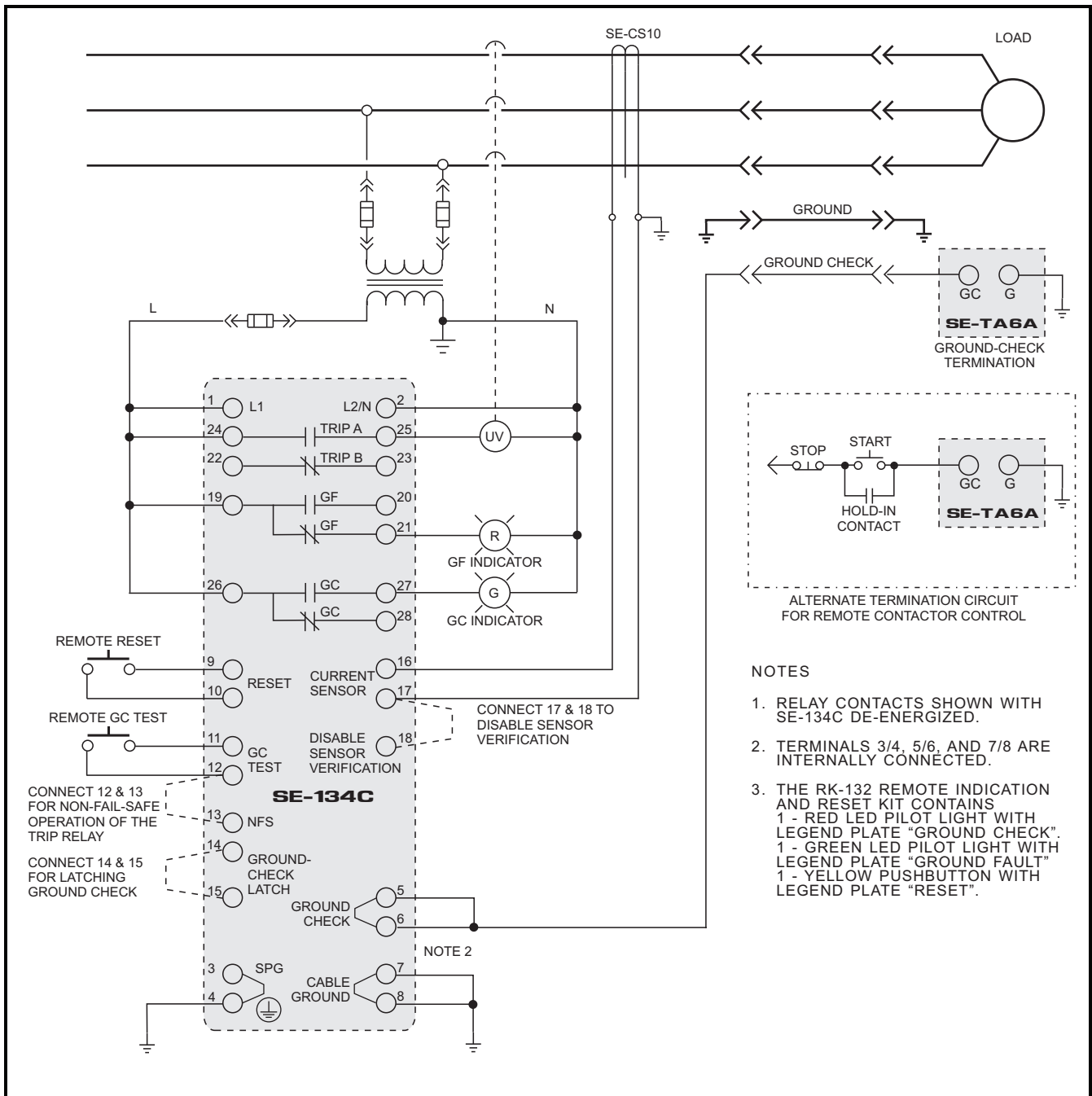

FIGURE 1. SE-134C Typical Application.

**NOTES**

1. RELAY CONTACTS SHOWN WITH SE-134C DE-ENERGIZED.
2. TERMINALS 3/4, 5/6, AND 7/8 ARE INTERNALLY CONNECTED.
3. THE RK-132 REMOTE INDICATION AND RESET KIT CONTAINS  
1 - RED LED PILOT LIGHT WITH LEGEND PLATE "GROUND CHECK".  
1 - GREEN LED PILOT LIGHT WITH LEGEND PLATE "GROUND FAULT".  
1 - YELLOW PUSHBUTTON WITH LEGEND PLATE "RESET".

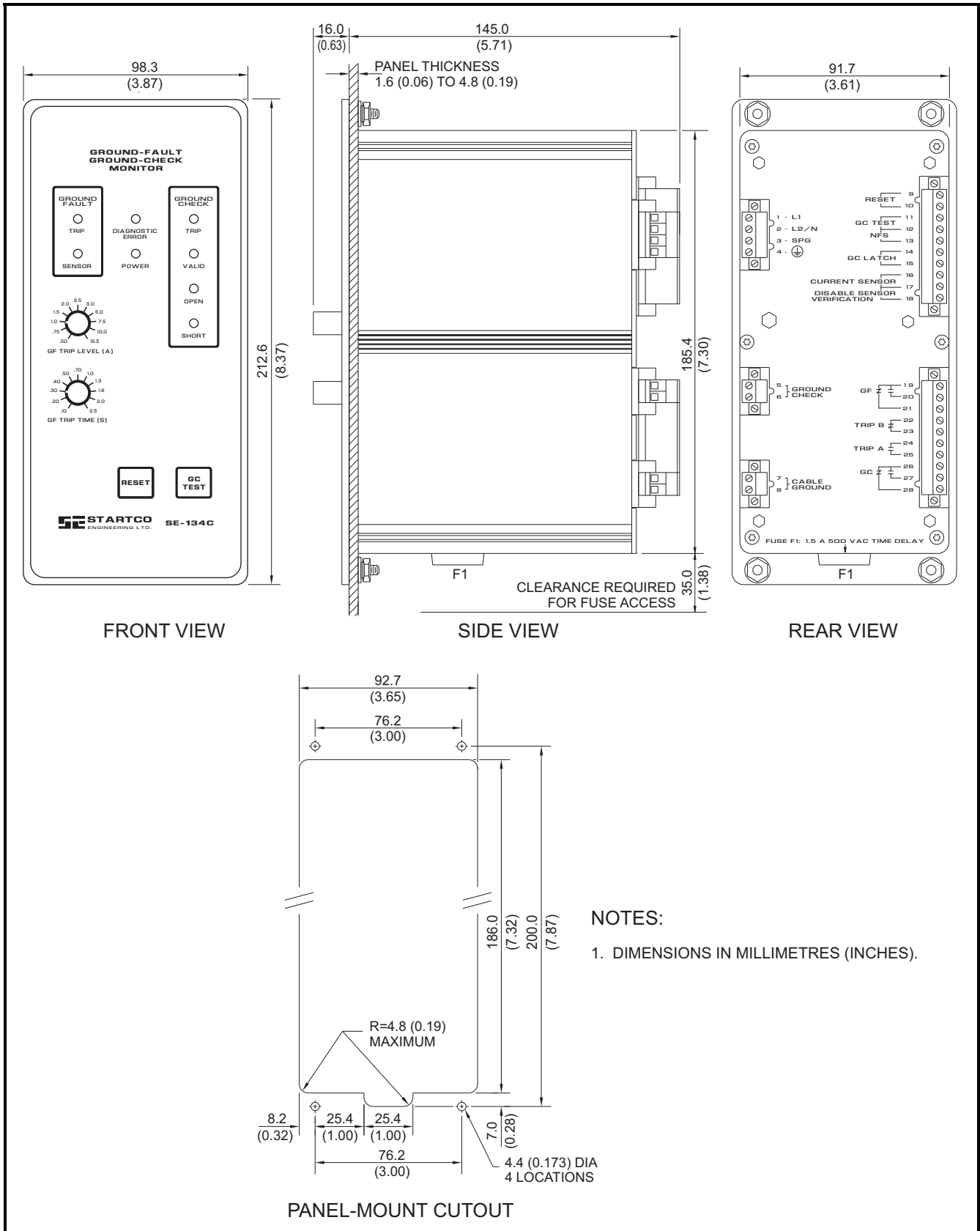

FIGURE 2. SE-134C Outline and Panel-Mounting Details.

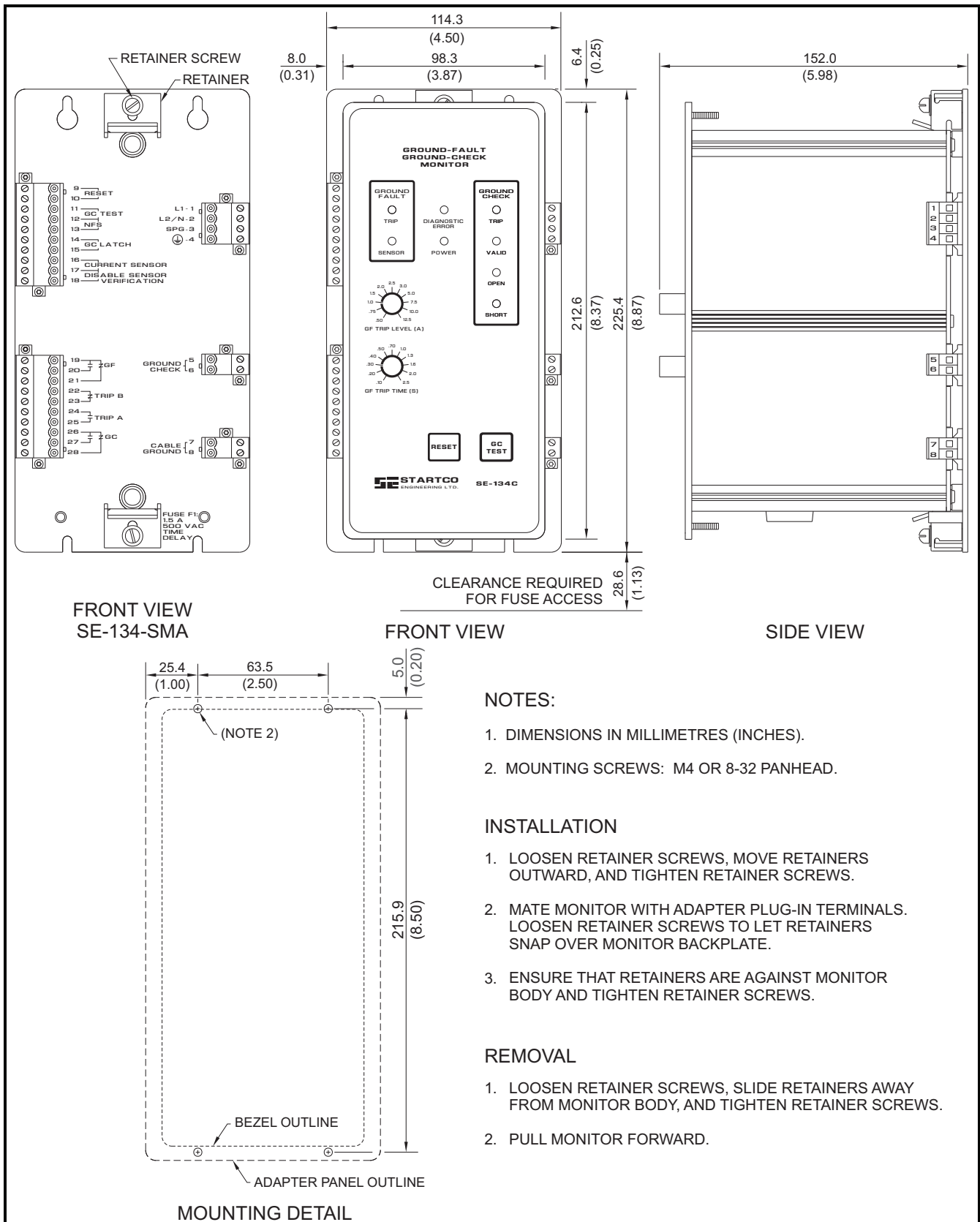

FIGURE 3. SE-134C Outline and Surface-Mounting Details.

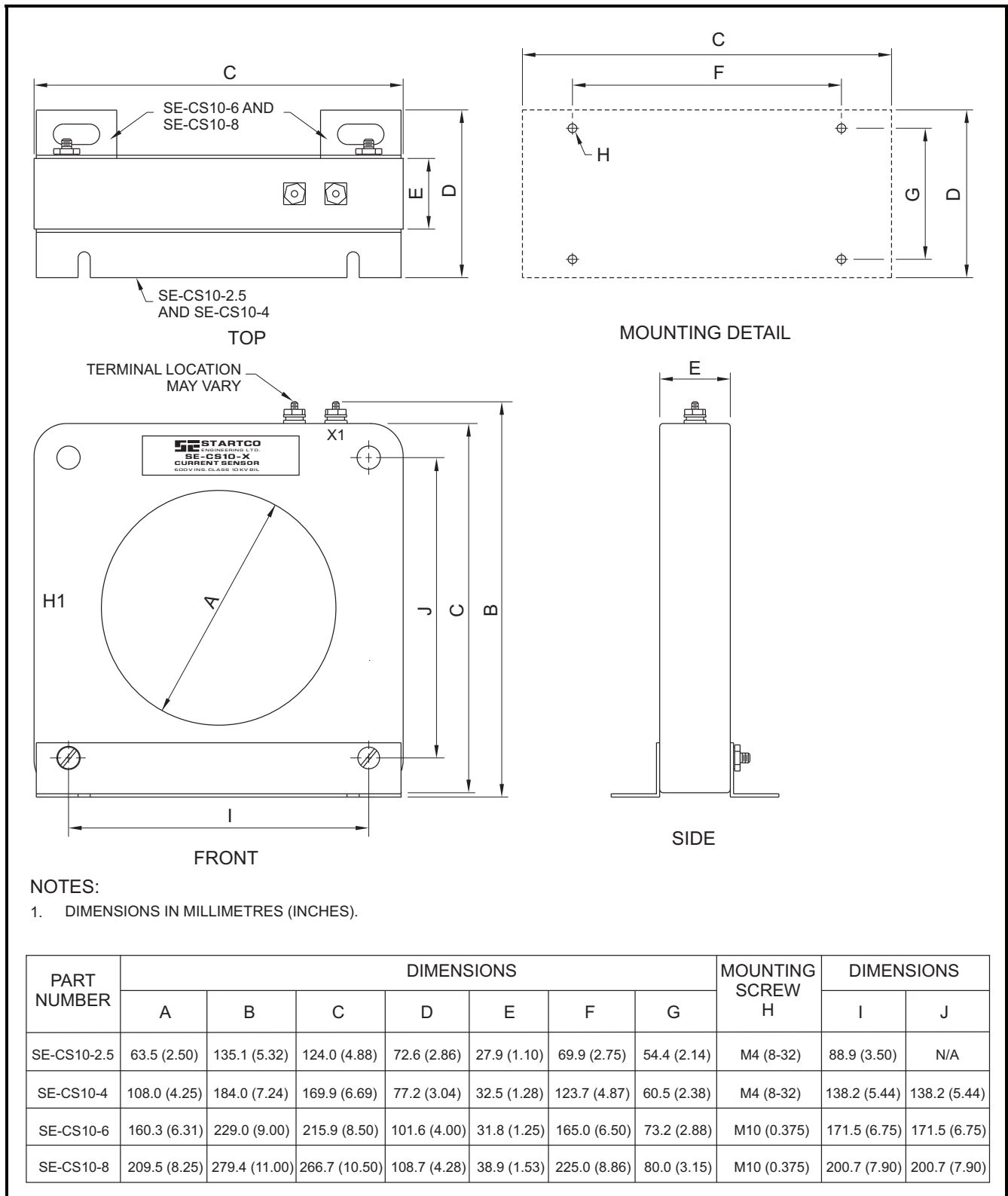

FIGURE 4. SE-CS10 Current Sensors.

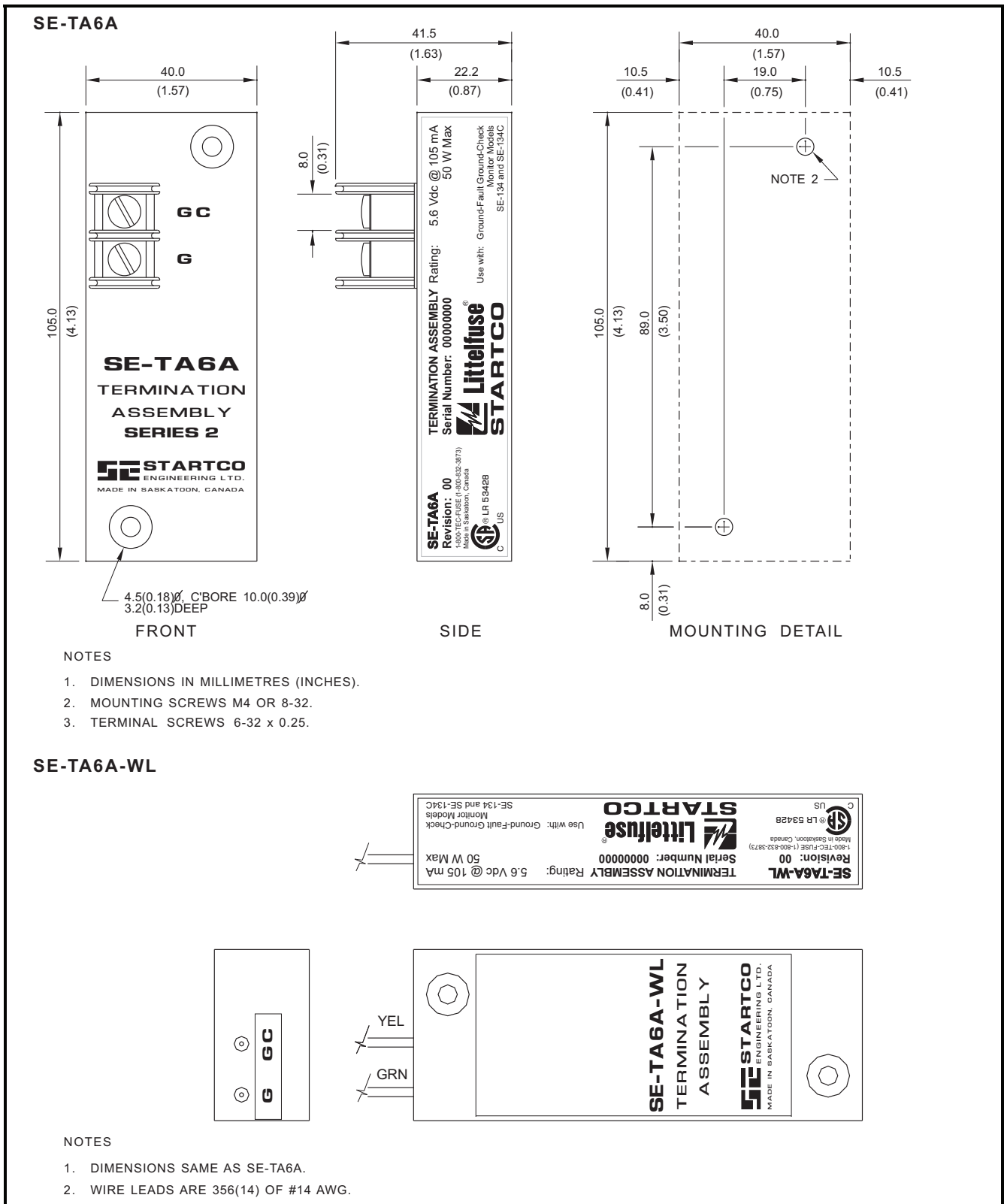

FIGURE 5. SE-TA6A and SE-TA6A-WL Termination Assemblies.

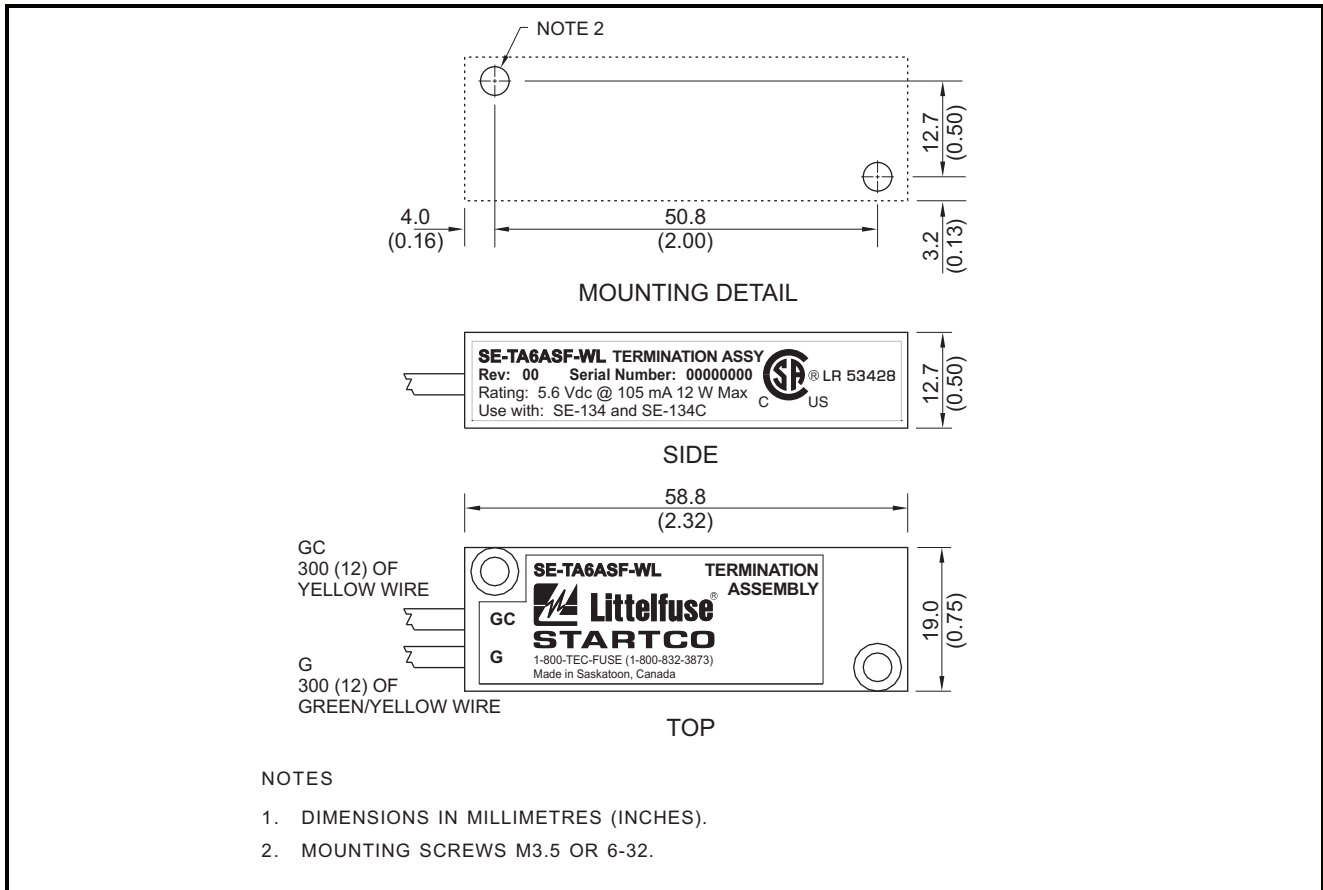

FIGURE 6. SE-TA6ASF-WL Small-Format Termination Assembly.

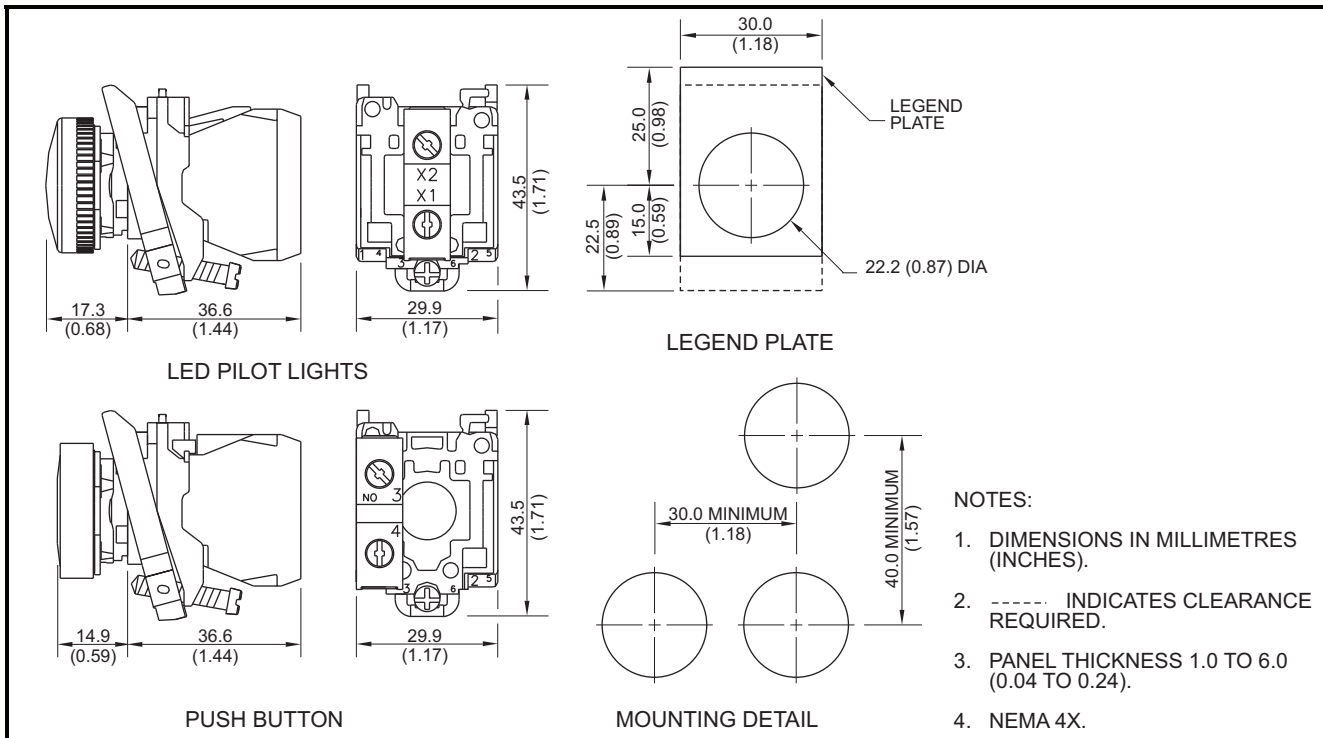

FIGURE 7. RK-132 Remote Indication and Reset.

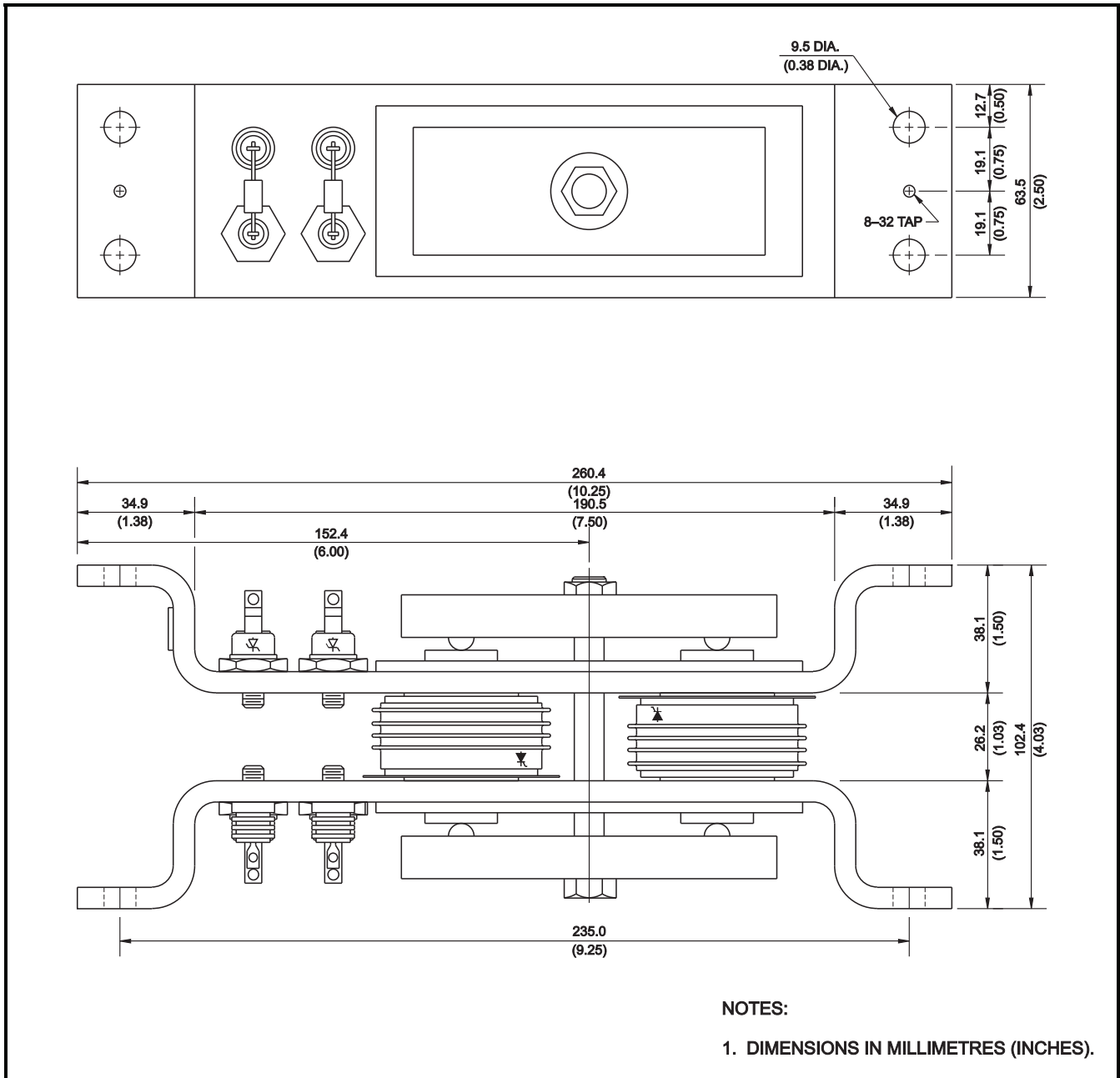

FIGURE 8. PPI-600V Parallel-Path Isolator.

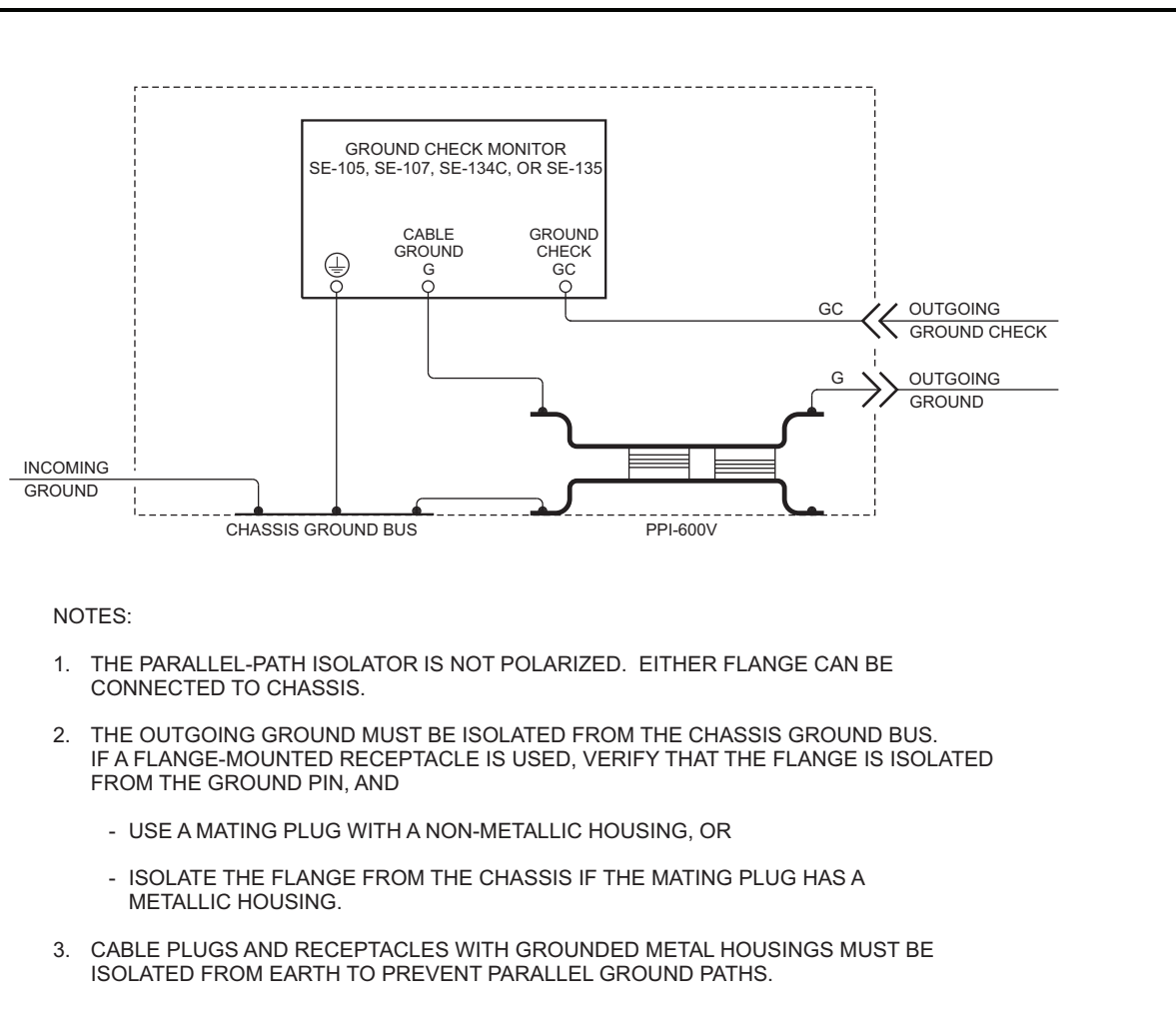

FIGURE 9. PPI-600V Typical Installation.

**5. TECHNICAL SPECIFICATIONS**

**5.1 SE-134C**

Supply:

Option 00.....	25 VA, 120-240 Vac (+10, -45%), 50-400 Hz, 15 W, 110-250 Vdc (+10, -25%)
Option 10 .....	15 W, 24-48 Vdc (+50, -25%) 20 VA, 24-48 Vac (+10, -55%), 50-100 Hz

Ground-Fault Circuit:

Digital Filter .....	50 to 60 Hz, Bandpass
3 dB Frequency Response..	30 to 90 Hz
Trip-Level Settings .....	0.5, 0.75, 1.0, 1.5, 2.0, 2.5, 3.0, 5.0, 7.5, 10.0, and 12.5 A
Trip-Time Settings .....	0.1, 0.2, 0.3, 0.4, 0.5, 0.7, 1.0, 1.3, 1.6, 2.0, and 2.5 s
Thermal Withstand.....	150 A Continuous 1,000 A for 2.5 s (Ground-Fault Current)
Sensor Lead Resistance.....	2 Ω maximum
Trip-Level Accuracy .....	± 5% or 0.1 A
Trip-Time Accuracy.....	+50, -15 ms
Sensor Verification .....	Enabled or Disabled
Operating Mode .....	Latching

Ground-Check Circuit:

Open-Circuit Voltage .....	24 Vdc
Output Impedance .....	136 Ω
Loop Current.....	105 mA
Induced ac Withstand.....	60 Vac Continuous, 120 Vac for 10 s, 250 Vac for 0.25 s
Pull-in Time .....	≤ 750 ms
Trip Resistance.....	28 Ω ± 10%
Trip Time @ 50 Ω.....	220 ± 30 ms
Isolation.....	3 kV, 60 Hz, 1 s
Test .....	Front-Panel Switch and Remote, N.O. Contact
Fuse Rating (F1).....	1.5 A, 500 Vac, Time Delay
Fuse Part Number.....	FNQ 1½ Buss Fusetron
Operating Mode .....	Latching or Non-Latching

Trip Relay:

CSA/UL Contact Rating ....	8 A Resistive 250 Vac 5 A 30 Vdc, ¼ HP, B300 Pilot Duty
Supplemental Contact Ratings:	
Make/Carry (0.2 s).....	30 A
Break dc .....	75 W Resistive, 35 W Inductive (L/R < 0.04)

Break ac .....	2,000 VA Resistive, 1,500 VA Inductive (PF > 0.4)
----------------	---

Subject to maximums of 8 A and 250 V (ac or dc)	
Contact Configuration.....	Isolated N.O. and N.C. Contacts
Operating Mode .....	Fail-Safe or Non-Fail-Safe

Remote-Indication Relays:

CSA/UL Contact Rating ....	8 A Resistive 250 Vac 8 A 30 Vdc
----------------------------	-------------------------------------

Supplemental Contact Ratings:

Make/Carry (0.2 s).....	20 A
Break dc .....	50 W Resistive, 25 W Inductive (L/R < 0.04)

Break ac .....	2,000 VA Resistive, 1,500 VA Inductive (PF > 0.4)
----------------	---

Subject to maximums of 8 A and 250 V (ac or dc)	
Contact Configuration.....	N.O and N.C. (Form C)
Operating Mode .....	Fail-Safe

Terminal Block Rating.....	10 A, 300 Vac, 12 AWG (2.5 mm <sup>2</sup> )
----------------------------	---

PWB Conformal Coating.....	MIL-1-46058 qualified, UL QMJU2 recognized
----------------------------	---

Mounting Configuration .....	Panel Mount and Surface Mount
------------------------------	----------------------------------

Shipping Weight .....	2.3 kg (5.1 lb)
-----------------------	-----------------

Environment:

Operating Temperature .....	-40°C to 60°C
Storage Temperature.....	-55°C to 80°C
Humidity .....	85% Non-Condensing

Surge Withstand.....	ANSI/IEEE 37.90.1-1989 (Oscillatory and Fast Transient)
----------------------	---

Certification .....	CSA Canada and USA
---------------------	--------------------



To:

CSA C22.2 No. 14 Industrial Control Equipment  
UL 508 Industrial Control Equipment  
UL 1053 Ground Fault Sensing and Relaying  
Equipment

Australia



**5.2 CURRENT SENSORS**

SE-CS10-2.5:

Current Ratio ..... 1,000:5 A  
Insulation ..... 600-V Class  
Window Diameter ..... 63 mm (2.5")  
Shipping Weight ..... 690 g (1.5 lb)

SE-CS10-4:

Current Ratio ..... 1,000:5 A  
Insulation ..... 600-V Class  
Window Diameter ..... 108 mm (4.2")  
Shipping Weight ..... 1.9 kg (4.3 lb)

SE-CS10-6:

Current Ratio ..... 1,000:5 A  
Insulation ..... 600-V Class  
Window Diameter ..... 160 mm (6.3")  
Shipping Weight ..... 2.2 kg (4.8 lb)

SE-CS10-8:

Current Ratio ..... 1,000:5 A  
Insulation ..... 600-V Class  
Window Diameter ..... 209 mm (8.2")  
Shipping Weight ..... 2.2 g (4.8 lb)

**5.3 TERMINATION ASSEMBLIES**

SE-TA6A:

Characteristic ..... 5.6-V Zener, Temperature  
Compensated  
Power Rating ..... 50 W  
Screw Terminal ..... 6-32 x 0.25  
Dimensions ..... 105 x 40 x 41.5 mm  
(4.13 x 1.57 x 1.63")  
Shipping Weight ..... 300 g (0.7 lb)

SE-TA6A-WL

Characteristic ..... 5.6-V Zener, Temperature  
Compensated  
Power Rating ..... 50 W  
Wire Leads ..... 14 AWG, 356 mm (14")  
Dimensions ..... 105 x 40 x 41.5 mm  
(4.13 x 1.57 x 1.63")  
Shipping Weight ..... 300 g (0.7 lb)

SE-TA6ASF-WL:

Characteristic ..... 5.6-V Zener, Temperature  
Compensated  
Power Rating ..... 12 W  
Wire Leads ..... 18 AWG, 300 mm (11.8")  
Dimensions ..... 51 x 19 x 12.7 mm  
(2 x 0.75 x 0.5")  
Shipping Weight ..... 45 g (0.1 lb)

Certification ..... CSA Canada and USA



**6. ORDERING INFORMATION**

SE-134C-

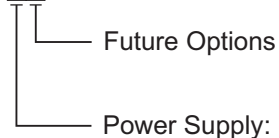

Power Supply:  
0 Universal ac/dc Supply  
1 24 to 48-Vdc Supply

SE-134C ..... Ground-Fault Ground-Check  
Monitor complete with  
SE-134-SMA  
Surface-Mount Adapter

Ground-Check Termination:

SE-TA6A ..... 50-W Standard Termination  
Assembly  
SE-TA6A-WL ..... 50-W Termination Assembly  
with Wire Leads  
SE-TA6ASF-WL ..... 12-W Small-Format Termination  
Assembly with Wire Leads

Current Sensors:

SE-CS10-2.5 ..... Current Sensor,  
63 mm (2.5") Window  
SE-CS10-4 ..... Current Sensor,  
108 mm (4.2") Window  
SE-CS10-6 ..... Current Sensor,  
160 mm (6.3") Window  
SE-CS10-8 ..... Current Sensor,  
209 mm (8.2") Window

Parallel Path Isolator

PPI-600V ..... For system voltages up to  
600 Vac

Accessories:

RK-132 ..... Remote Indication and Reset,  
Includes two 120-V pilot  
lights, a reset push button, and  
legend plates

## 7. WARRANTY

The SE-134C Ground-Fault Ground-Check Monitor is warranted to be free from defects in material and workmanship for a period of five years from the date of purchase.

Littelfuse Startco will (at Littelfuse Startco's option) repair, replace, or refund the original purchase price of an SE-134C that is determined by Littelfuse Startco to be defective if it is returned to the factory, freight prepaid, within the warranty period. This warranty does not apply to repairs required as a result of misuse, negligence, an accident, improper installation, tampering, or insufficient care. Littelfuse Startco does not warrant products repaired or modified by non-Littelfuse Startco personnel.

Littelfuse Startco is not liable for contingent or consequential damages; for expenses sustained as a result of incorrect application, incorrect adjustment, or a malfunction; or for expenses resulting from the use of, or inability to use, the product.

## 8. TEST PROCEDURES

### 8.1 GROUND-CHECK TRIP TESTS

#### 8.1.1 LATCHING GROUND-CHECK TRIP TEST

- Connect the monitor, current sensor and termination assembly as shown in Fig 10. Connect terminals 14 and 15 for latching operation. With supply voltage applied, the POWER, SENSOR, and VALID LED's will be on.
- Open the ground-check loop by removing either the GC or G connection between the monitor and the termination assembly. Pressing the faceplate GC TEST button will also perform an open-ground-check test. The monitor will trip. The trip contacts (terminals 22-23 and 24-25) and the ground-check indication contacts (terminals 26-27 and 26-28) will change state. The VALID LED will be off, and both the GROUND CHECK TRIP and the OPEN LED's will be on.
- Reconnect the ground-check loop. The VALID and TRIP LED's will be on and the OPEN LED will be flashing. The TRIP contacts (terminals 22-23 and 24-25) will remain latched and ground-check indication contacts (terminals 26-27 and 26-28) will change state.
- Reset the monitor.
- Short the ground-check loop by connecting G to GC. The monitor will trip. The trip contacts (terminals 22-23 and 24-25) and the ground-check indication contacts (terminals 26-27 and 26-28) will change state. The VALID LED will be off, and both the GROUND CHECK TRIP and the SHORT LED's will be on.
- Remove the short from G to GC. The VALID and TRIP LED's will be on and the SHORT LED will be flashing. The TRIP contacts (terminals 22-23 and 24-25) will remain latched and ground-check indication contacts (terminals 26-27 and 26-28) will change state.
- Reset the monitor.

#### 8.1.2 NON-LATCHING GROUND-CHECK TRIP TEST

- Connect the monitor, current sensor and termination device as shown in Fig. 10. With supply voltage applied, the POWER, SENSOR, and VALID LED's will be on.
- Open the ground-check loop by removing either the GC or G connection between the monitor and the termination assembly. Pressing the faceplate GC Test button will also perform an open circuit test. The monitor will trip. The trip contacts (terminals 22-23 and 24-25) and the ground-check indication contacts (terminals 26-27 and 26-28) will change state. The VALID LED will be off, and both the GROUND CHECK TRIP and the OPEN LED's will be on.
- Reconnect the ground-check loop. The monitor will reset.
- Short the ground-check loop by connecting G to GC. The monitor will trip. The trip contacts (terminals 22-23 and 24-25) and the ground-check indication contacts (terminals 26-27 and 26-28) will change state. The VALID LED will be off, and both the GROUND CHECK TRIP and the SHORT LED's will be on.
- Remove the short from G to GC. The monitor will reset.

#### 8.2. TRIP RELAY FAIL-SAFE MODE TEST

- Connect the monitor, current sensor and termination device as shown in Fig. 10. With supply voltage applied, the POWER, SENSOR, and VALID LED's will be on. The output contacts between terminals 22 and 23 will be open and between 24 and 25 will be closed.
- Remove the supply voltage. The output contacts between terminals 22 and 23 will close and the output contacts between terminals 24 and 25 will open.

#### 8.3 CURRENT-SENSOR-VERIFICATION TEST

- Connect the monitor, current sensor and termination device as shown in Fig. 10. With supply voltage applied, the POWER, SENSOR, and VALID LED's will be on.
- Open the current-sensor circuit by disconnecting one of the sensor leads. The monitor will trip. The trip contacts (terminals 22-23 and 24-25) and the ground-fault indication contacts (terminals 19-20 and 19-21) will change state. The GROUND FAULT TRIP LED will be on and the SENSOR LED will be off.
- Reconnect the current sensor. The GROUND FAULT TRIP LED will stay on and the SENSOR LED will flash. The output contacts will remain latched.
- Reset the monitor.
- Short the current sensor by connecting terminals 16 and 17. The monitor will trip. The trip contacts (terminals 22-23 and 24-25) and the ground-fault indication contacts (terminals 19-20 and 19-21) will change state. The GROUND FAULT TRIP LED will be on and the SENSOR LED will be off.



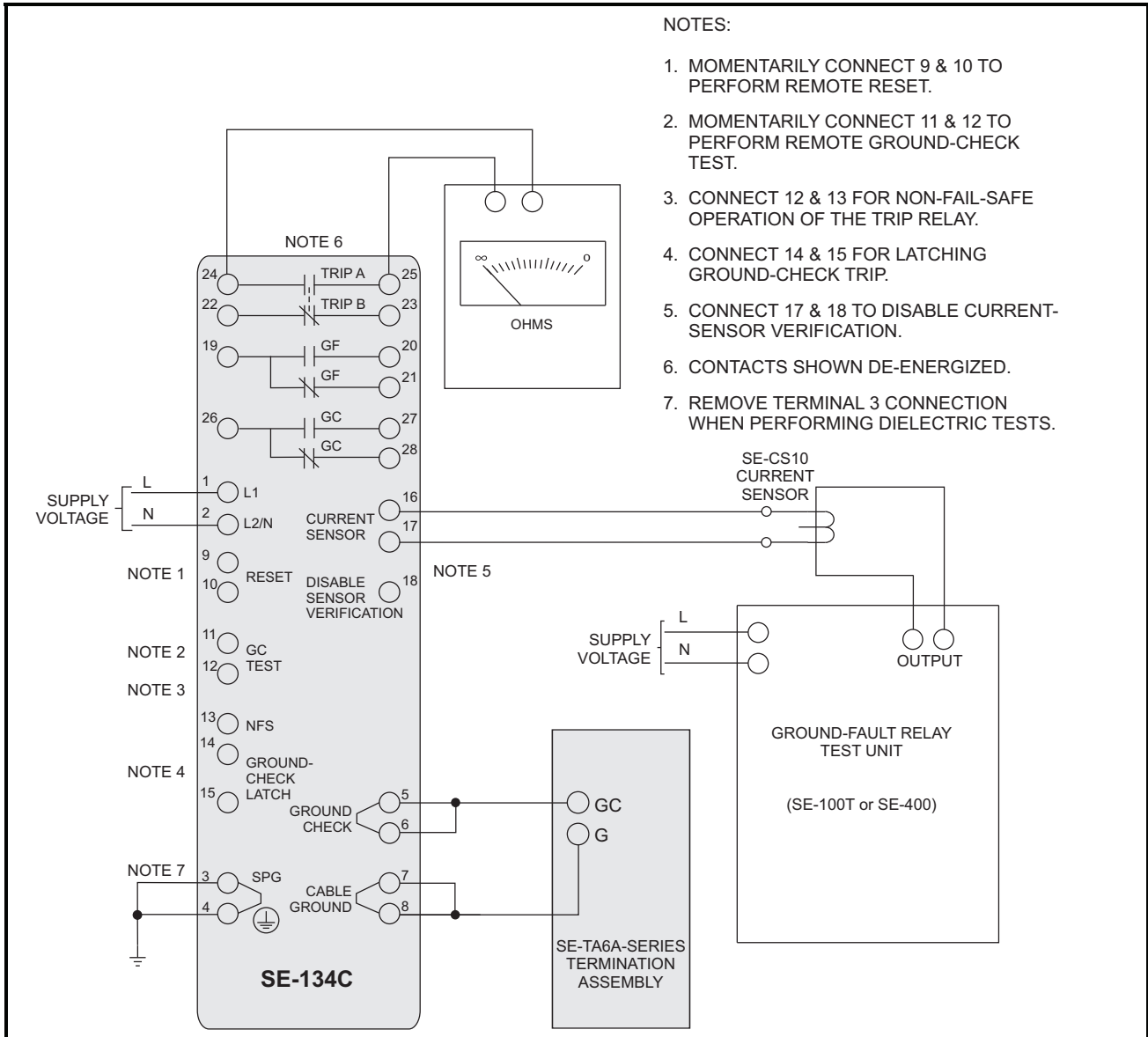

FIGURE 10. Ground-Fault-Test Circuit.

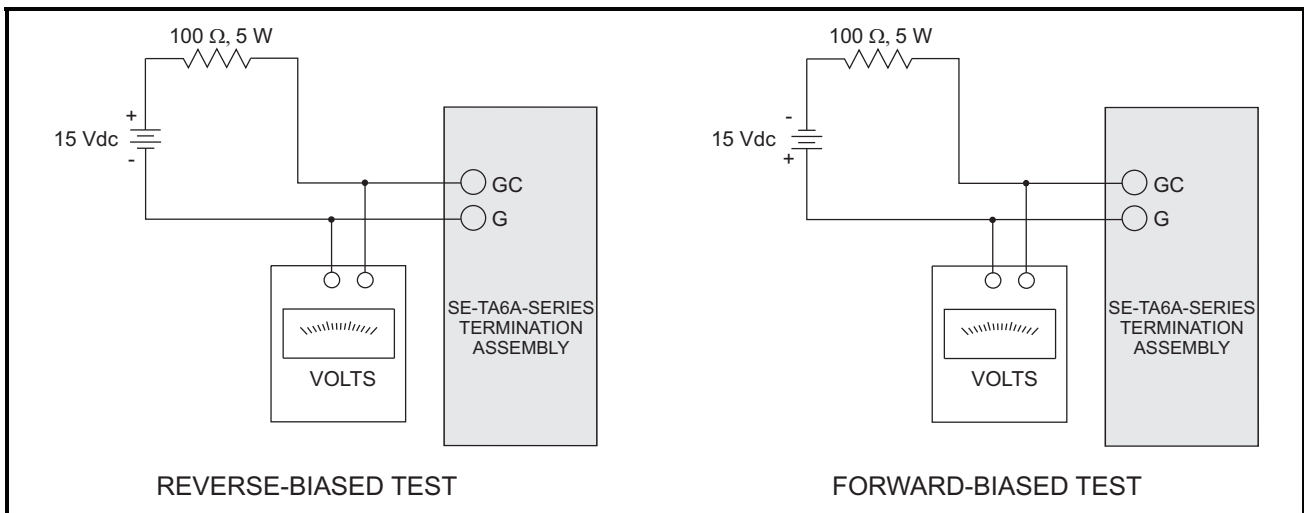

FIGURE 11. Termination-Assembly-Test Circuits.