

Digital Filter
for harmonic
rejection

Uses SE-TA6A, 6-Volt
Termination Assembly

Manuals and additional
information available at
www.startco.ca

SE-134C

GROUND-FAULT GROUND-CHECK MONITOR

The SE-134C is a microprocessor-based, combination ground-fault and ground-check monitor for resistance-grounded systems. It has a switching power supply that accepts a wide range of ac and dc voltages, its specifications apply over an industrial temperature range at high humidity, and it meets the IEEE surge-withstand-capability tests (oscillatory and fast transient) for protective relays and relay systems. All operating conditions are clearly indicated and two Form C contacts are provided for remote indication. Isolated, normally open and normally closed contacts are provided for contactor control or for shunt or undervoltage operation in a breaker-trip circuit.

The ground-fault circuit detects fundamental-frequency, zero-sequence current with a window-type current sensor and it verifies that the current sensor is connected and not shorted. A definite-time characteristic with 11 trip levels and 11 trip times allows coordination in virtually any resistance-grounded system. A ground-fault trip is latched.

The ground-check circuit has an output drive current above 100 mA for optimum performance in slipping, commutated-load, and high-induced-ac applications. Features include an externally accessible ground-check fuse, a resistance-insertion test, 3-kV isolation between the ground-check loop and the monitor electronics, and a PPI-600V accessory for parallel-ground-path rejection.

TYPICAL APPLICATION

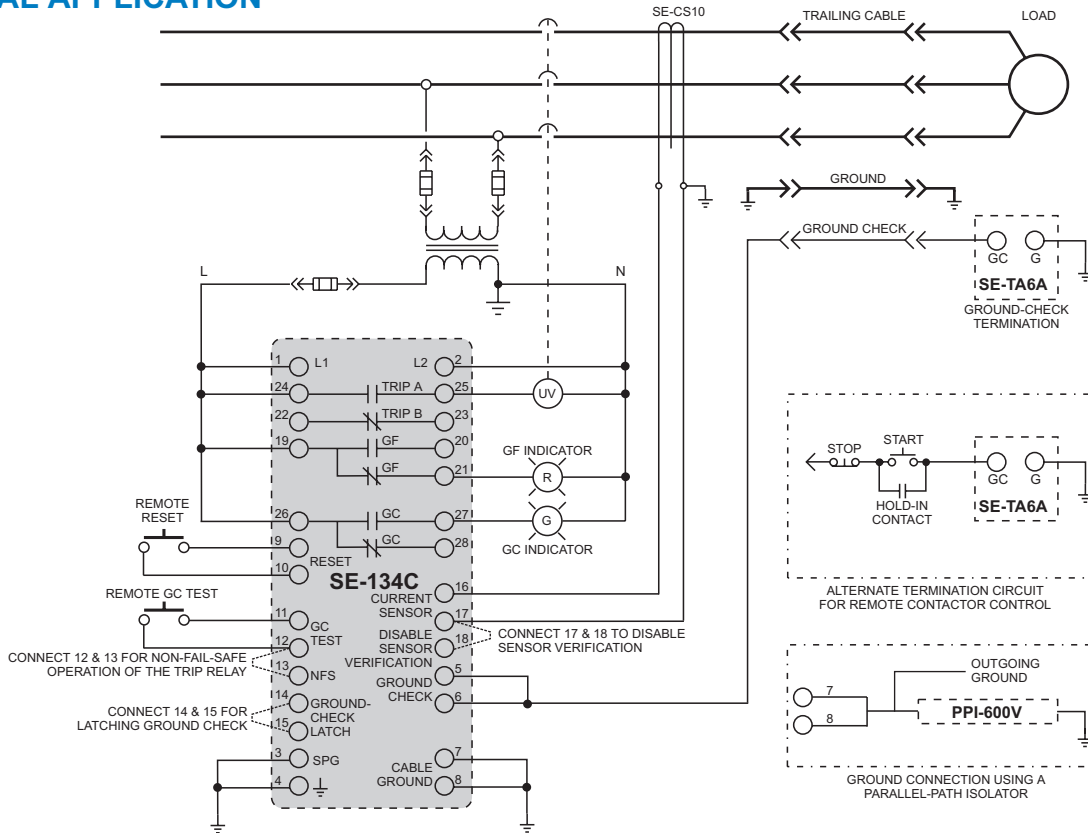

TECHNICAL SPECIFICATIONS

Supply:

60 to 265 Vac, 47 to 440 Hz, 25 VA
80 to 370 Vdc, 15 W

Monitor Dimensions (Panel Mount):

Height 213 mm (8.4")
Width 99 mm (3.9")
Depth:
Behind Panel 145 mm (5.7")
In Front of Panel 16 mm (0.7")

Ground-Fault Circuit:

Digital Filter 50 to 60 Hz, Bandpass
Trip-Level Settings 0.5, 0.75, 1.0, 1.5, 2.0, 2.5, 3.0, 5.0,
7.5, 10.0, and 12.5 A
Trip-Time Settings 0.1, 0.2, 0.3, 0.4, 0.5, 0.7, 1.0, 1.3, 1.6,
2.0, and 2.5 s
Thermal Withstand 150 A Continuous,
1000 A for 2.5 s (Ground-Fault Current)
Trip-Level Accuracy $\pm 5\%$ or 0.1 A
Trip-Time Accuracy +50, -15 ms
Sensor Verification Enabled or Disabled
Operating Mode Latching

Ground-Check Circuit:

Open-Circuit Voltage 24 Vdc
Output Impedance 136 Ω
Loop Current 105 mA
Induced ac Withstand 60 Vac Continuous, 120 Vac for 10 s,
250 Vac for 0.25 s
Pull-In Time ≤ 750 ms
Trip Time @ 50 Ω 220 \pm 30 ms
GC-Loop Trip Resistance 28 $\Omega \pm 10\%$
Isolation 3 kV, 60 Hz, 1 s
Test Front-Panel Switch and
Remote, N.O. Contact
Fuse Rating (F1) 1.5 A, 500 Vac, Time Delay
Fuse Part Number FNQ 1/2 Buss Fuse/Tron
Operating Mode Latching or Non-Latching

Trip Relay:

CSA/UL Contact Rating 8 A Resistive 250 Vac
Supplemental Contact Ratings:
Make/Carry (0.2 s) 30 A
Break dc 75 W Resistive,
35 W Inductive (L/R < 0.04)
Break ac 2000 VA Resistive,
1500 VA Inductive (PF > 0.4)
Subject to maximums of 8 A and 250 V (ac or dc)
Contact Configuration Isolated N.O. and N.C. Contacts
Operating Mode Fail-Safe or Non-Fail-Safe

Remote-Indication Relays:

CSA/UL Contact Rating 8 A Resistive 250 Vac
Supplemental Contact Ratings:
Make/Carry (0.2 s) 20 A
Break dc 50 W Resistive,
25 W Inductive (L/R < 0.04)
Break ac 2000 VA Resistive,
1500 VA Inductive (PF > 0.4)
Subject to maximums of 8 A and 250 V (ac or dc)
Contact Configuration Form C
Operating Mode Fail-Safe

Environment:

Operating Temperature -40°C to 60°C
Storage Temperature -55°C to 80°C
Humidity 85% Non-Condensing

Surge Withstand:

ANSI/IEEE 37.90.1-1989
(Oscillatory and Fast Transient)

ORDERING INFORMATION

SE-134C GF-GC Monitor c/w SE-134-SMA
Surface-Mount Adapter
SE-TA6A Termination Assembly
SE-CS10-4 Current Sensor, 108 mm (4.2") Window
SE-CS10-6 Current Sensor, 160 mm (6.3") Window
SE-CS10-8 Current Sensor, 209 mm (8.2") Window
PPI-600V Parallel-Path Isolator

Specifications are subject to change without notice. Startco Engineering Ltd. is not liable for contingent or consequential damages, or for expenses sustained as a result of incorrect application, incorrect adjustment, or a malfunction.

Copyright © 2001.
Printed in Canada.
Publication: SE-134C-D
Revised: 20010814



406 Jessop Avenue, Saskatoon, Saskatchewan, Canada S7N 2S5
Phone: (306) 373-5505 Fax: (306) 374-2245 www.startco.ca