

# PGR-6150 SERIES

## Motor Protection System

MOTOR PROTECTION RELAYS

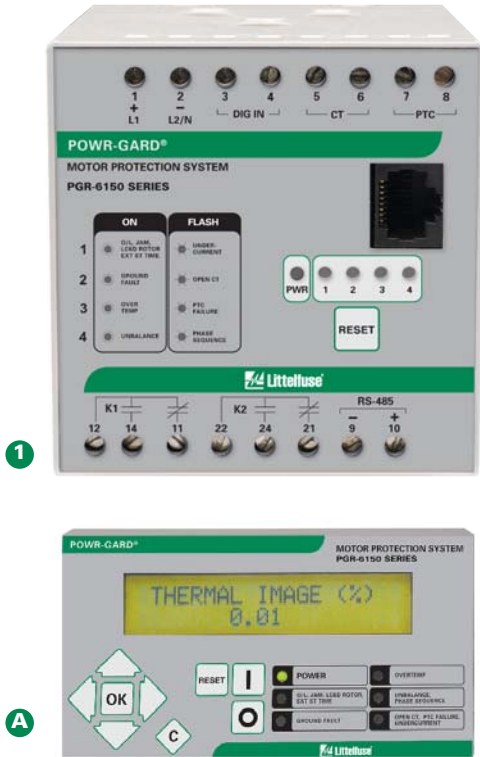

### Description

The PGR-6150 Motor Protection System provides 13 protective functions by utilizing both current and temperature inputs. It is a modular system consisting of the control unit and an operator interface (PGR-6150-OPI). The OPI allows programming and displays metered values. The PGR-6150 is used to provide current- and temperature-based protection, metering and data logging for three-phase motors used in industrial environments. Current transformers are not required for currents up to 25 A.

#### 1 Control Unit

- Integrated phase CTs (external for applications > 25 A)
- Ground-fault CT input
- One PTC input and one programmable input
- Two programmable output contacts
- Eight status LEDs
- RS-485 Communications
- DIN-rail mountable
- PC interface software

#### A Operator Interface (optional)

- Large, bright, LCD display (2 x 20 alphanumeric characters)
- Keypad for menu selection (system parameters, measurements, and fault reports)
- Displays metered values
- Six user-programmable LEDs
- Powered by Control Unit
- 1 meter (39 inch) connection cable included

### Wiring Diagram

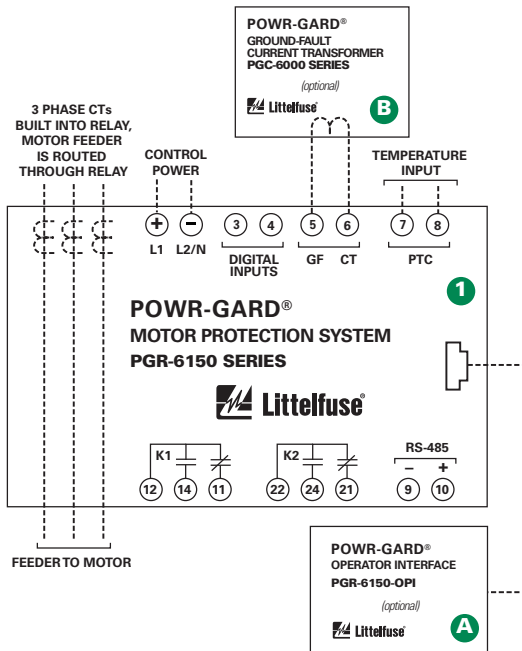

### Simplified Circuit Diagram

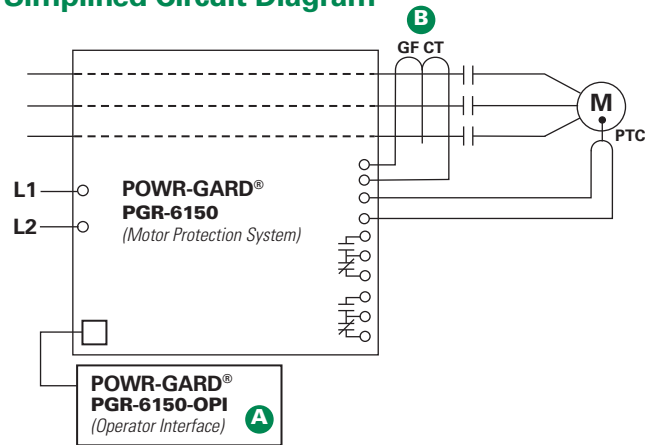

### Accessories

**A**  **PGR-6150-OPI Operator Interface**  
Optional Operator Interface for displaying metered values and programming

**B**  **PGC-6000 Series Ground-Fault Transformer**  
Optional zero-sequence current transformer, used to measure ground-fault current. Required for applications >25 A.

### Features & Benefits

FEATURES	IEEE #	BENEFITS
<b>No CTs required</b>	49, 51	No current transformers are required for currents < 25 A
<b>Adjustable Trip Settings</b>		Adjustable overload trip class setting from 5 to 45 to match motor characteristics
<b>Digital Input</b>		Programmable digital input
<b>Output Contacts</b>		Two programmable Form C output contacts for operation of separate annunciation and trip circuits
<b>Overload</b>	49, 51	Extends motor life and prevents insulation failures and fires
<b>Overcurrent/Jam</b>	50, 51	Detects catastrophic failures and fires; extends motor life
<b>Undercurrent</b>	37	Detects low level or no-load conditions
<b>Unbalance (Current)</b>	46	Prevents overheating due to unbalanced phases
<b>Phase Loss/Phase Sequence</b>	46	Detects unhealthy supply conditions
<b>PTC Overtemperature</b>	49	Detect high ambient or blocked ventilation and single phasing; prevents shaft/pump damage
<b>Dynamic Thermal Model</b>		Provides protection through starting, running, overload, and cooling cycles
<b>Communications</b>		RS-485 communications to remotely display metered values

### Dynamic Thermal Modeling

#### Without Thermal Memory

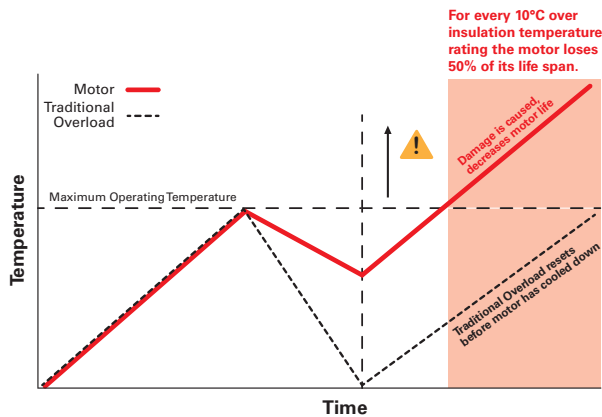

#### With Thermal Memory

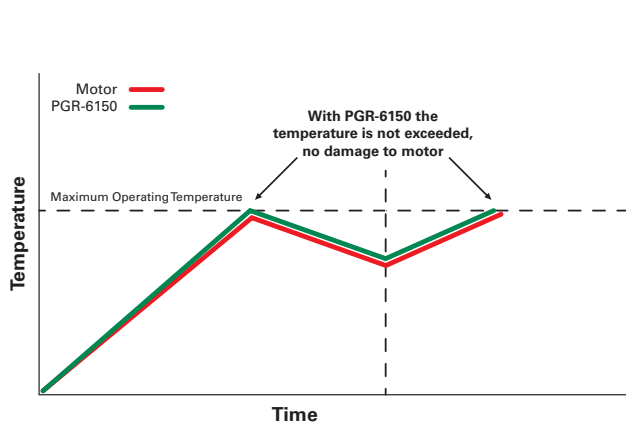

### Ordering Information

CATALOG/SYSTEM NUMBER	CONTROL POWER
PGR-6150-24 (Control Unit)	24/48 Vdc
PGR-6150-240 (Control Unit)	120/240 Vac/dc
PGR-6150-OPI (Operator Interface)	Powered by Control Unit

NOTE: External CTs can be used for full-load currents >25 A.

ACCESSORIES	REQUIREMENT	PAGE
PGH-6000 Series	Optional	45

### Specifications

<b>Protective Functions (IEEE Device Numbers)</b>	Overload (49, 51)	PTC overtemperature (49)
	Phase sequence (46)	Failure to accelerate
	Overcurrent (50, 51)	RTD temperature (49)
	Jam	Unbalance (current) (46)
	Ground fault (50G/N, 51G/N)	Starts per hour (66)
	Undercurrent (37)	Phase loss (current) (46)
<b>Input Voltage</b>	110-230 Vac/Vdc; 24/48 Vdc, 5 W	
<b>AC Measurements</b>	RMS, 16 samples/cycle	
<b>Frequency</b>	50, 60 Hz	
<b>Dimensions (Control Unit)</b>	<b>H</b> 83 mm (3.3"); <b>W</b> 78 mm (3.1"); <b>D</b> 99 mm (3.9")	
<b>(Operator Interface)</b>	<b>H</b> 56 mm (2.2"); <b>W</b> 106 mm (4.2"); <b>D</b> 22.8 mm (0.9")	
<b>Output Contacts</b>	Two Form C	
<b>Communications</b>	RS-485 with Modbus® RTU	
<b>Approvals</b>	Consult factory	
<b>Warranty</b>	5 years	
<b>Mounting</b>	DIN (Control Unit); Panel (Operator Interface)	