

## PGR-6130 SERIES

### Electronic Overload Relay

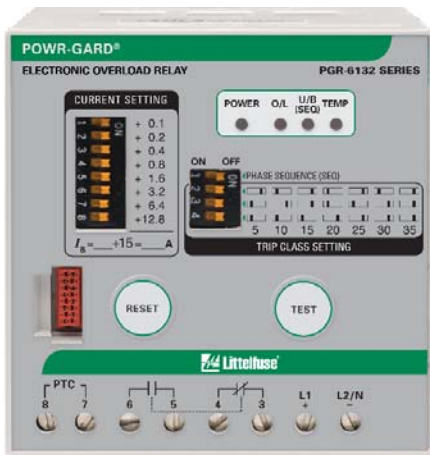

### Wiring Diagram

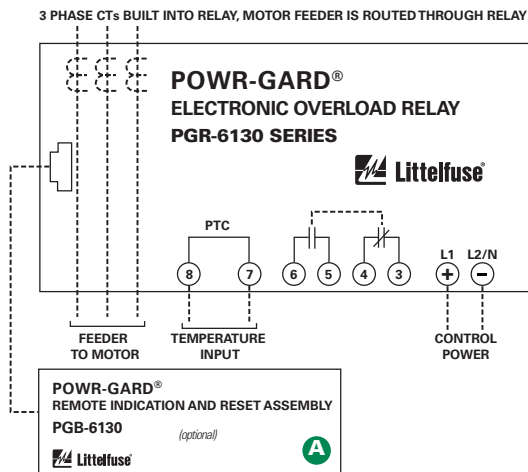

### Ordering Information

CATALOG/SYSTEM NUMBER	CONTROL POWER	FULL-LOAD CURRENT
PGR-6131-24	24 Vdc	4-16.7 A
PGR-6131-120	120 Vac	4-16.7 A
PGR-6131-240	240 Vac	4-16.7 A
PGR-6132-24	24 Vdc	15-40.5 A
PGR-6132-120	120 Vac	15-40.5 A
PGR-6132-240	240 Vac	15-40.5 A
PGR-6133-24	24 Vdc	40-91 A
PGR-6133-120	120 Vac	40-91 A
PGR-6133-240	240 Vac	40-91 A

NOTE: External CTs can be used for full-load currents >91 A.

ACCESSORIES	REQUIREMENT	PAGE
PGB-6130	Optional	43

### Description

The PGR-6130 Electronic Overload Relay provides protection for small three-phase motors up to 1,000 Vac. No current transformers are required for currents up to 91 A. The protective functions include overload, overtemperature, phase unbalance, phase loss, and phase sequence. The PGR-6130 Electronic Overload Relay offers dependable protection and can be used on pumps, conveyor belts, ventilation fans and other small-motor applications that require standard protection.

### Features & Benefits

FEATURES	BENEFITS
<b>No CTs Required</b>	No current transformers required for currents up to 91 A
<b>Adjustable Trip Settings</b>	Adjustable overload trip class setting from 5 to 35 to match motor characteristics
<b>Output Contacts</b>	Form A and Form B ground-fault output contacts for operation of separate annunciation and trip circuits
<b>Remote Indication</b>	Allows remote cause-of-trip indication and reset
<b>Overload</b>	Extends motor life and prevents insulation failures and fires
<b>Phase Loss/Phase sequence</b>	Detects unhealthy supply conditions
<b>Unbalance (Current)</b>	Prevents overheating due to unbalanced phases
<b>PTC Overtemperature</b>	Detect high ambient or blocked ventilation and single phasing; prevents shaft/pump damage

### Accessories

A



#### PGB-6130 Remote Indication and Reset Assembly

Optional remote indication of overcurrent, phase unbalance, phase loss, phase sequence and overtemperature. Remote reset included.

### Specifications

<b>Protective Functions (IEEE Device Numbers)</b>	Overload (49, 51) Phase sequence (46) Overcurrent (51) PTC overtemperature (49) Unbalance (current) (46) Phase loss (current) (46)
<b>Input Voltage</b>	See ordering information
<b>Frequency</b>	50, 60 Hz
<b>Dimensions</b>	<b>H</b> 83 mm (3.3"); <b>W</b> 78 mm (3.1"); <b>D</b> 99 mm (3.9")
<b>Test Button</b>	Standard feature
<b>Reset Button</b>	Standard feature
<b>Output Contacts</b>	Isolated Form A and Form B
<b>Approvals</b>	UL listed
<b>Warranty</b>	5 years
<b>Mounting</b>	DIN