



## APPENDIX H MPU-CTI

### H.1 GENERAL

A typical connection diagram for an MPU-32 with an MPU-CTI Current Transformer Interface is shown in Fig. H.1.

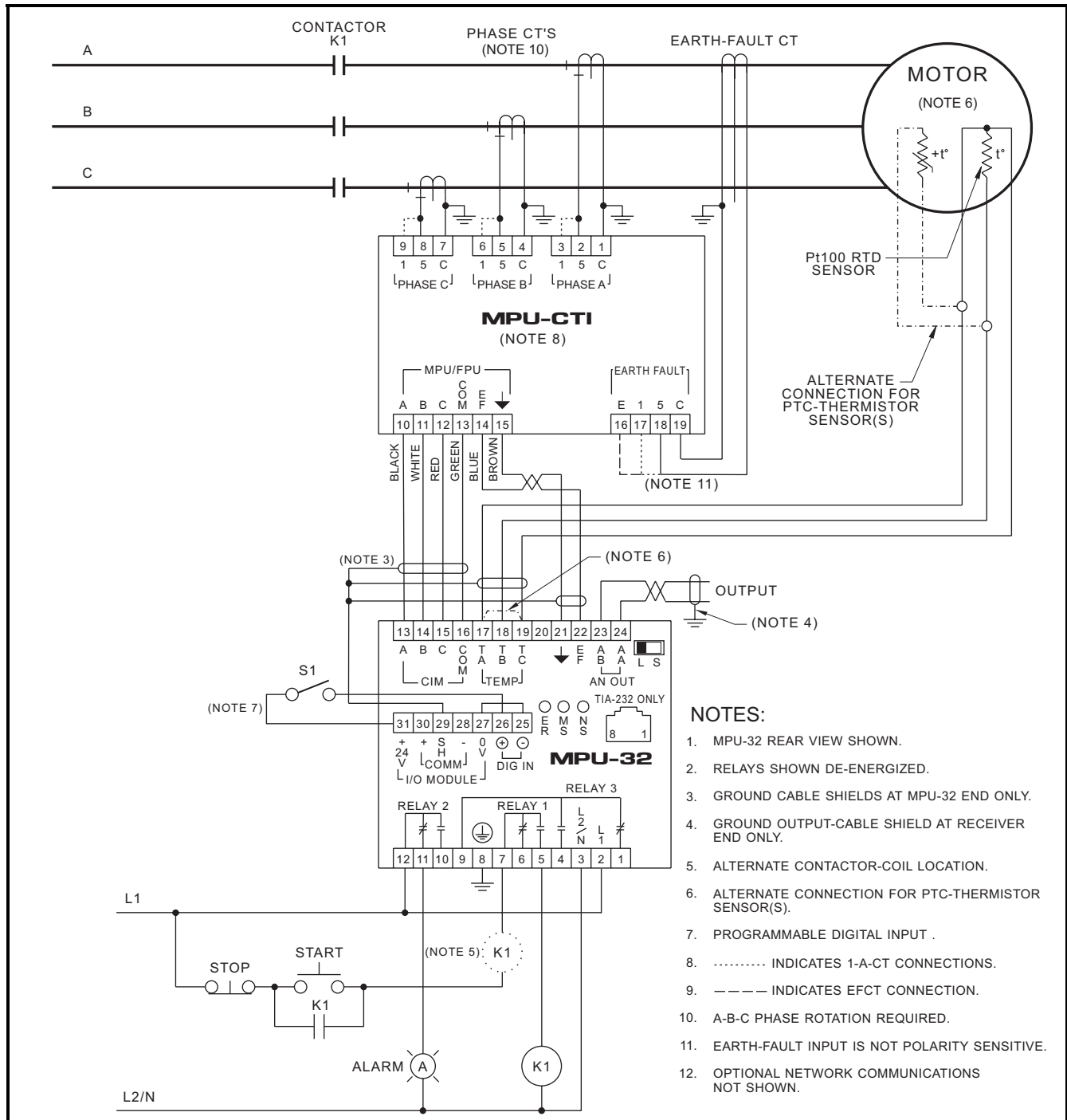

FIGURE H.1 Typical MPU-32 Connection Diagram.



## H.2 MPU-CTI CONNECTIONS

The MPU-CTI contains four signal-conditioning interface transformers which are interconnected as shown in Fig. H.2. These transformers isolate the MPU-32 from the phase and earth-fault CT's. The MPU-CTI eliminates the need for CT shorting contacts when the MPU-32 is disconnected.

All CT inputs can withstand a common-mode voltage of 120 Vac so that the MPU-CTI can be connected in series with other CT loads. Figure H.1 shows a typical connection where the MPU-CTI is the only device connected to the phase CT's. A 1-A, 5-A, or sensitive CT is used for core-balance earth-leakage measurement.

**NOTE:** A-B-C phase sequence and polarity must be observed when connecting phase CT's. See Section 4.2.1.

The MPU-CTI can be surface or DIN-rail mounted. Outline, mounting and ordering information are shown in Fig. H.3. To minimize CT-lead burden an MPU-CTI can be located close to the CT's.

The MPU-CTI CT-input terminal blocks accept No. 8 (M4) ring terminals. The remaining MPU-CTI clamping blocks accept 24 to 12 AWG (0.2 to 2.5 mm<sup>2</sup>) conductors.

Connect the MPU-CTI to the MPU-32 as shown in Figs. H.4 and H.5 using the cable provided with the MPU-CTI.

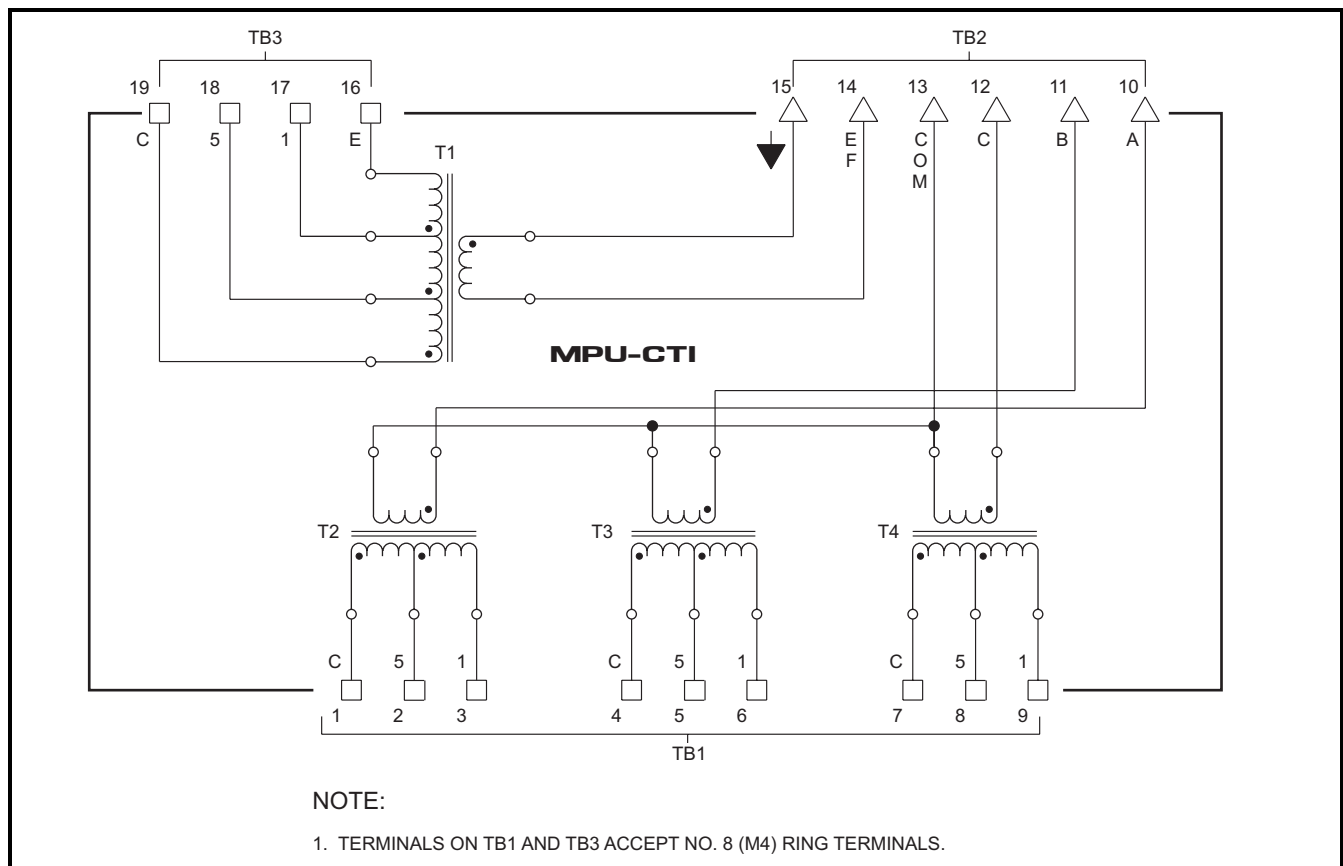

FIGURE H.2 MPU-CTI Schematic.

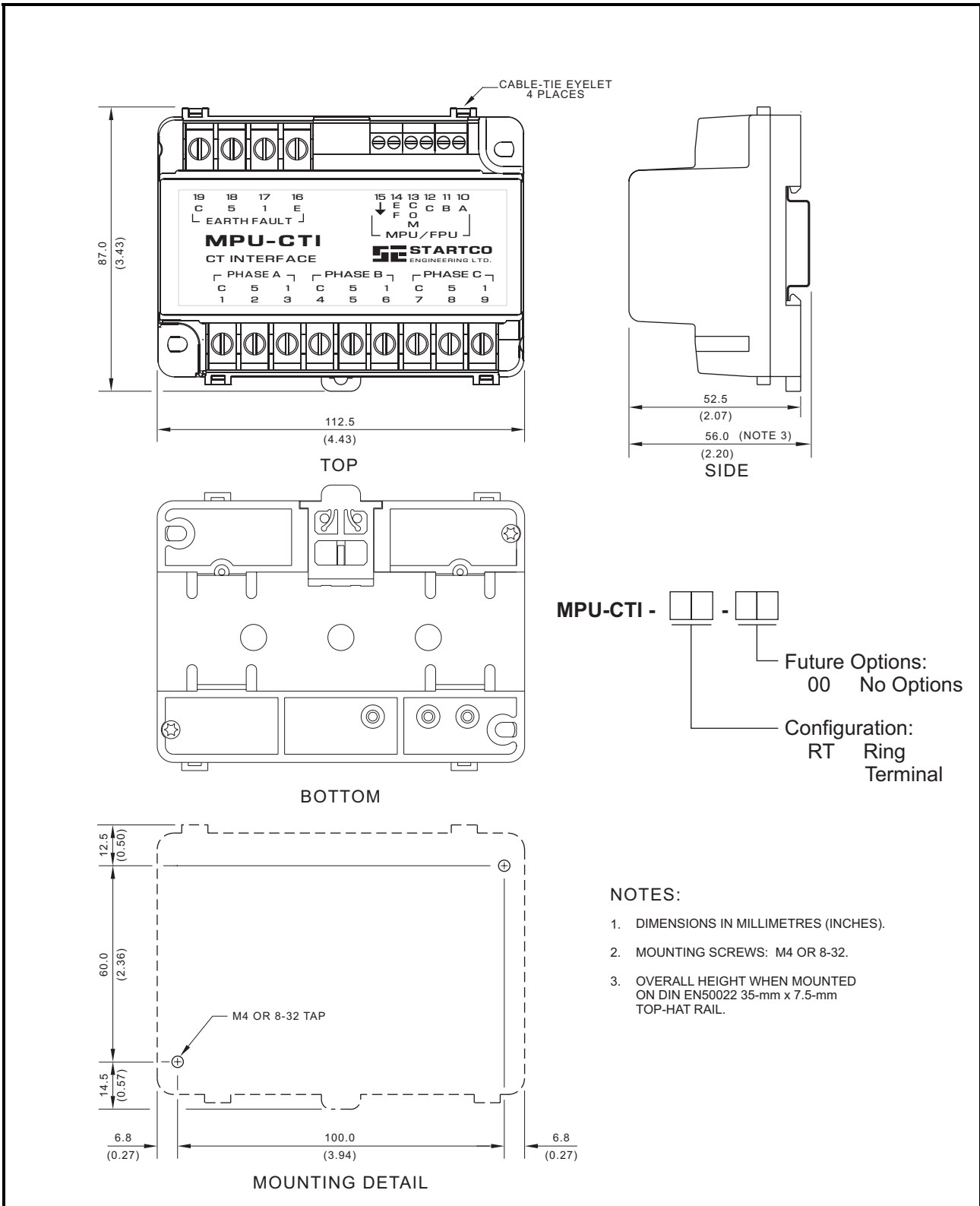

FIGURE H.3 MPU-CTI Outline, Mounting and Ordering Information.



### H.2.1 STANDARD

Standard connections with earth-fault CTs are shown in Fig. H.4. Dotted lines indicate 1-A-CT connections and dashed lines indicate sensitive-CT connections. Use shielded cable for EFCT-1, EFCT-2 or EFCT-26 connections. Ensure only current-carrying phase conductors pass through the earth-fault-CT window and that ground conductors do not.

### H.2.2 RESIDUAL EARTH-FAULT

The residual earth-fault connection is not required — the MPU-32 calculates residual current. See Section 4.2.2.

### H.2.3 Two-CT

The two-CT connection is shown in Fig. H.5. Dotted lines indicate 1-A-CT connections and dashed lines indicate sensitive-CT connections. Since this connection derives the current in the unmonitored phase, it should be used only in retrofit applications where it is not possible to install a third CT. For earth-fault protection an earth-fault CT is required.

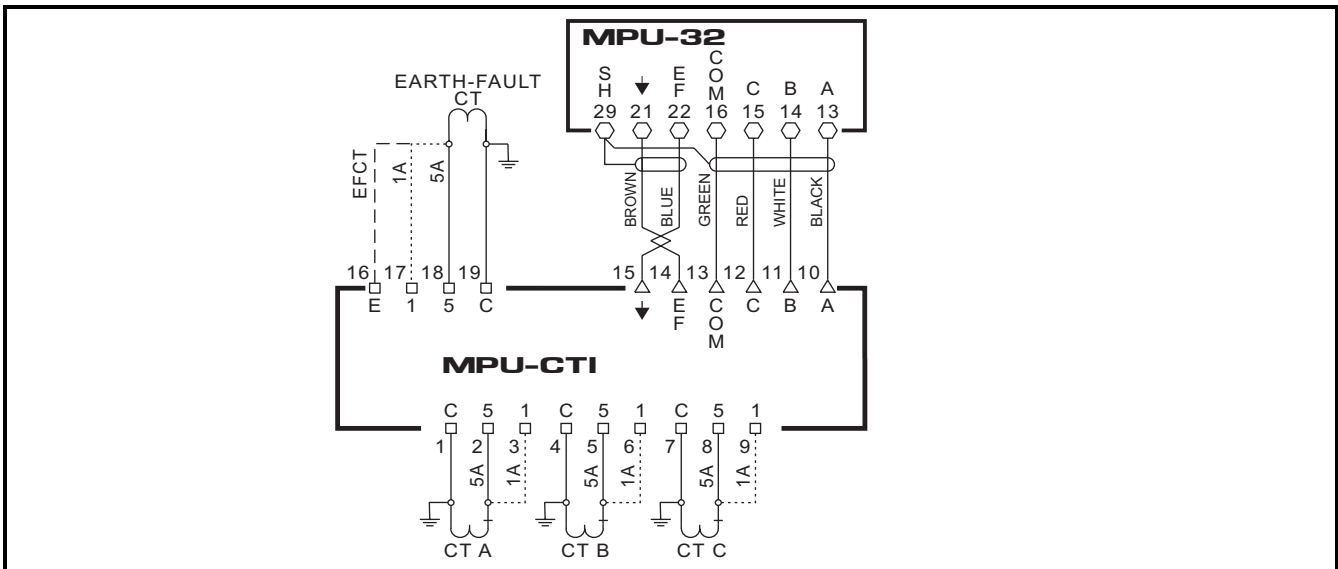

FIGURE H.4 MPU-CTI Standard Connection.

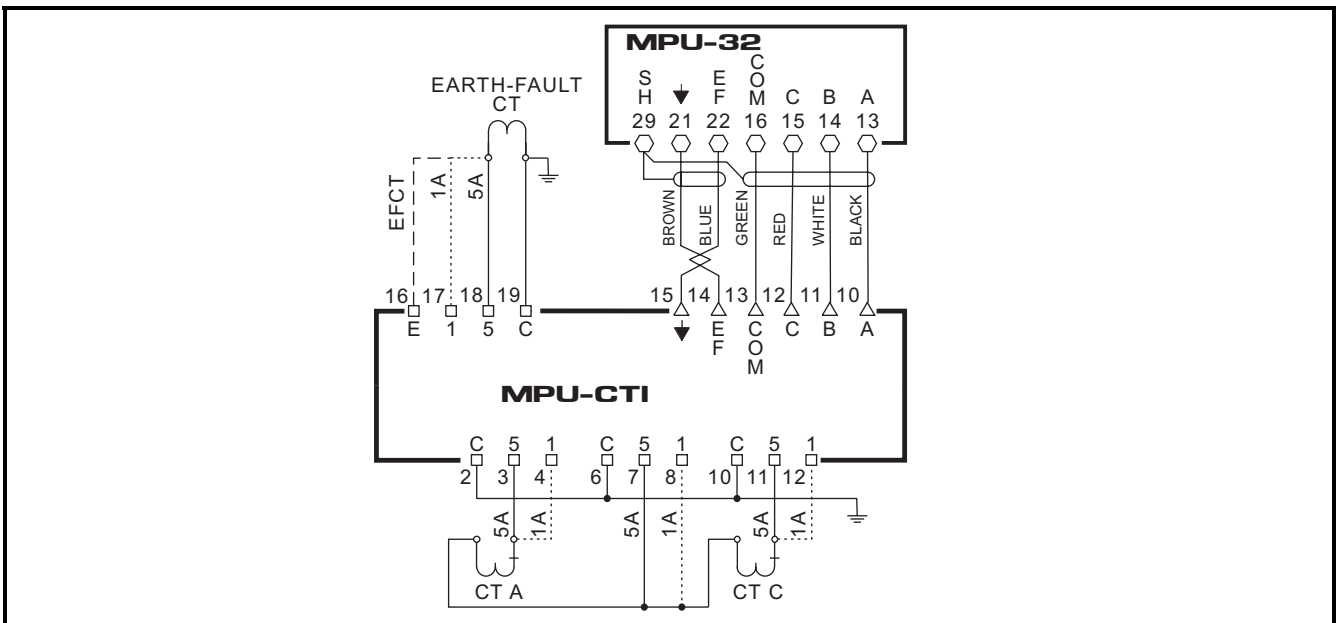

FIGURE H.5 Two-CT Connection.