

Manuals and additional information available at [www.startco.ca](http://www.startco.ca)

## IDM-3

### 3-PHASE AMMETER

The IDM-3 is a microprocessor-based three-phase ammeter that provides instantaneous and peak lagged-demand ammeter readings. It uses inputs from 5-A-secondary current transformers connected to an interface CT to simplify installation and eliminate the need for CT shorting contacts. Operational features of the IDM-3 include keypad programming, sampling and digital-integration techniques developed for the MPU-16A Motor Protection Unit, and isolated analog outputs for a data-acquisition system. The CT-primary rating, lagged-demand response time, output update time, and SCADA interface are all keypad programmable.

# TYPICAL APPLICATION

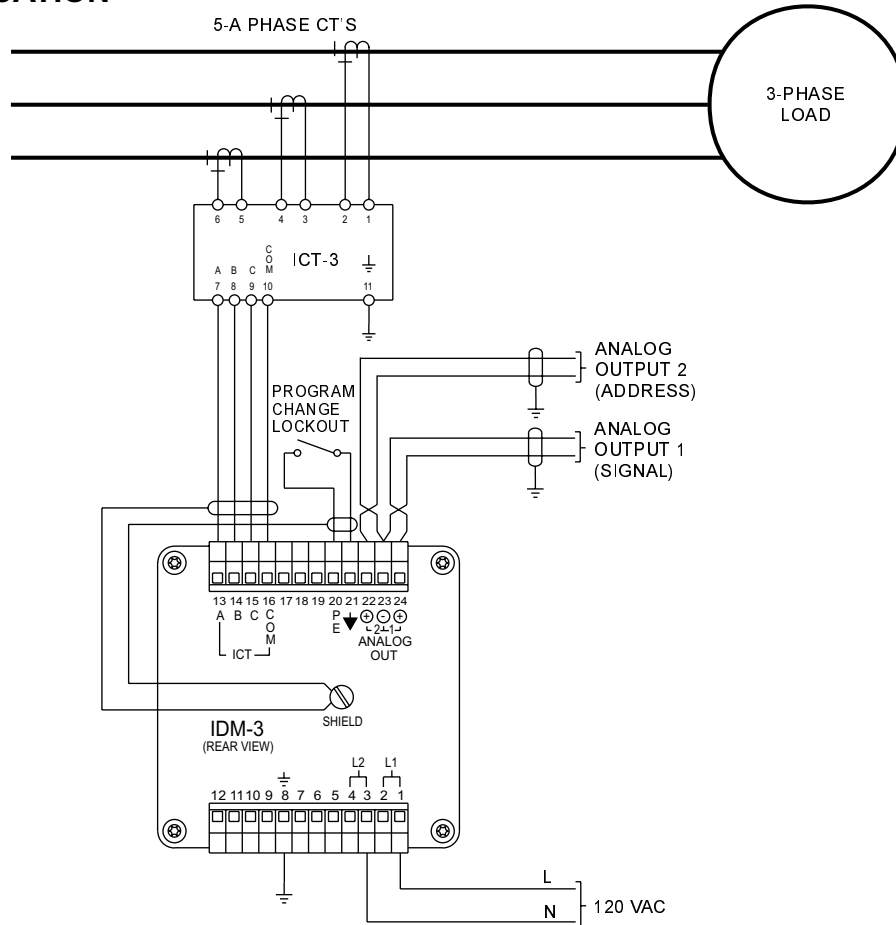

## TECHNICAL SPECIFICATIONS

Supply:  
 120 or 240 Vac, 50/60 ± 1 Hz . . . . . 10 VA  
 Maximum Continuous . . . . . 135/265 Vac  
 Minimum Continuous . . . . . 85/170 Vac  
 Power-up Voltage . . . . . 100/200 Vac

Dimensions (Panel Mount):  
 Height . . . . . 96 mm (3.8")  
 Width . . . . . 96 mm (3.8")  
 Depth . . . . . 158 mm (6.2")

Interface-CT Inputs:  
 Thermal Withstand  
 Continuous . . . . . 8 A  
 1-Second . . . . . 80 A  
 Burden . . . . . < 0.05 Ω

Accuracy (Interface CT Included):  
 Ammeter Accuracy . . . . . ± 3% CT-Primary Rating

SCADA Interface:  
 Type . . . . . Dual Analog Output  
 Configuration . . . . . Output 1 — Signal Amplitude  
 . . . . . Output 2 — Address Code  
 Output-1 Range . . . . . 0 to 100% CT-Primary Rating  
 Output-1 Overrange . . . . . 125% Full Scale  
 Output Drive:  
 4–20 mA . . . . . 700 Ω  
 0–5 mA . . . . . 3 kΩ  
 0–1 mA . . . . . 15 kΩ  
 0–5 V . . . . . 25 mA  
 0–1 V . . . . . 25 mA  
 Resolution . . . . . ± 1% Full Scale  
 Isolation to Ground . . . . . 300 Vac Continuous  
 Dielectric Strength . . . . . 1500 Vac

Environment:  
 Operating Temperature . . . . . -40°C to 60°C  
 Storage Temperature . . . . . -55°C to 80°C

## ORDERING INFORMATION

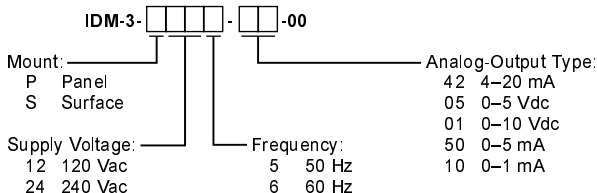

Specifications are subject to change without notice. Startco Engineering Ltd. is not liable for contingent or consequential damages, or for expenses sustained as a result of incorrect application, incorrect adjustment, or a malfunction.

Copyright © 1999.  
 Printed in Canada.  
 Publication: IDM-3-D  
 Revised: 9904 Printed: 9904



406 Jessop Avenue, Saskatoon, Saskatchewan, Canada S7N 2S5  
 Phone: (306) 373-5505 Fax: (306) 374-2245 www.startco.ca