

Expertise Applied | Answers Delivered



WHITE
PAPER



Tony Locker, PE
and
Jakob Seedorff,
Technical Director
Littelfuse, Inc.

ARC-FLASH PROTECTION

Key Considerations for Selecting an Arc-Flash Relay

Introduction

Arc-Flash Relays are an effective defense against dangerous Arc-Flash events, and the decision to include such a relay in a design is an easy one. Less easy, however, is selecting the optimal relay for an application.

Abstract

According to OSHA, industrial Arc-Flash events cause about 80% of electrically related accidents and fatalities among qualified electrical workers. Even if personnel injuries are avoided, Arc Flash can destroy equipment, resulting in costly replacement and downtime. In response, many designers are adding Arc-Flash relays to electrical systems. These devices greatly mitigate the effects of an Arc Flash by detecting a developing incident and sending a trip signal to a breaker to disconnect the current that feeds it. Arc-Flash Relays are complex devices; an understanding of the technical details of their operation and features is essential. This white paper covers key points of Arc-Flash relay technology so that specifying engineers, OEM designers, and end users can make an informed selection decision.

Arc-Flash Mitigation

NFPA 70E goes into great detail on procedures to avoid electrical shock and Arc-Flash events by opening and locking out circuit breakers before working on electrical equipment. When work on a live system is required, this standard spells out approach distances, use of personal protection equipment and apparel, and other precautions.

An important part of a prevention strategy, Arc-Flash relays (Figure 1) are often installed in switchgear cabinets. These compact devices are designed to detect a developing Arc Flash extremely fast and send a trip signal to a circuit breaker, which significantly reduces the total clearing time and subsequent damage. This is accomplished by providing an output that directly activates an electrical system circuit breaker to cut off current flow to the arcing fault.

The fastest Arc-Flash relays available on the market today will detect a developing Arc-Flash and send a trip signal to a breaker in as little as 1 ms. The breaker will typically take an additional 35-50 ms to open, depending on the type of breaker and how well it is maintained. Because an Arc Flash can draw a fraction of bolted-fault current, especially in the early stages, circuit breakers alone cannot be relied upon to distinguish between the arcing current and a typical inrush current. That's why installing an Arc-Flash relay to rapidly detect those developing incidents greatly reduces the total clearing time and the amount of energy released through an arcing fault. In turn, there is less damage to equipment, plus there are fewer and less severe injuries to nearby personnel. Generally, this minor damage is limited to the fault point where the arc originates, and avoids the more widespread and severe damage that occurs in a full-blown Arc Flash.

Using a system circuit breaker to clear the fault also avoids the need to purchase and install a separate switching device. This allows a more compact Arc-Flash relay design that can fit in an existing switchgear cabinet.

Figure 1.
Example of an Arc-Flash Relay

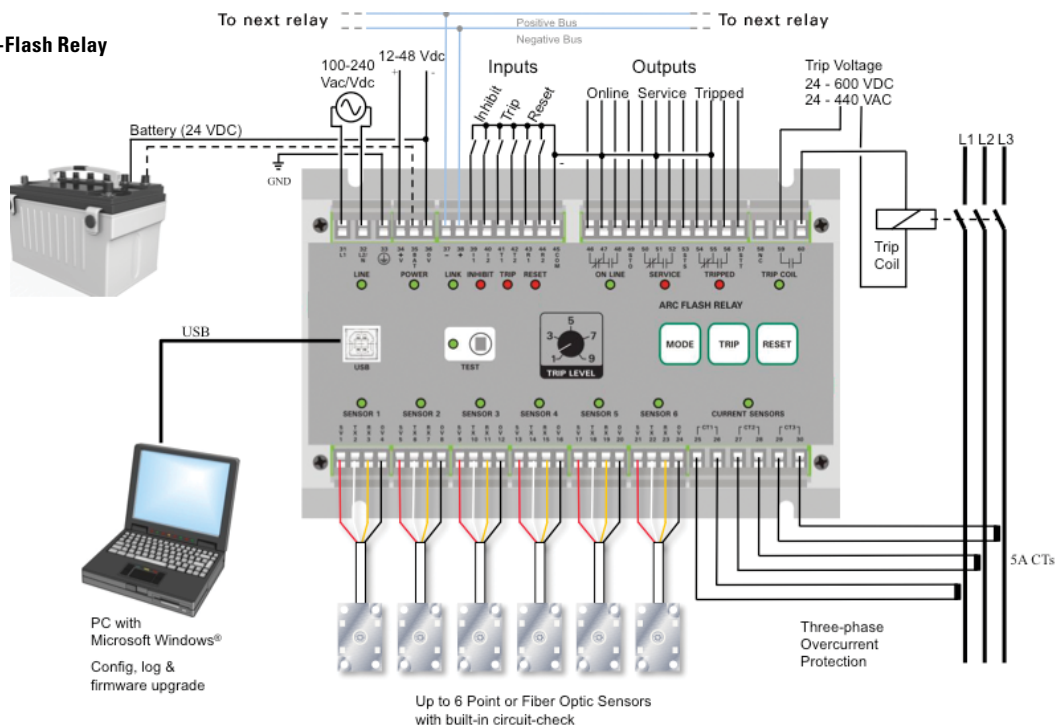

Key Selection Criteria

Still, it is important to evaluate other design aspects of the Arc-Flash relays you are considering for this important function. The most important selection criteria are:

1. Reaction time
2. Trip reliability
3. Avoidance of nuisance tripping
4. Sensor design and installation
5. Ease of use
6. Scalability and flexibility

1. Reaction Time

When evaluating an Arc-Flash relay's reaction time, keep in mind the timing of events that typically occur during an arcing fault. In the early stages of an Arc Flash, the arcing current is too low to trip a circuit breaker, which is sized to tolerate temporary rises in current caused by transients, such as motor inrush current. For example, on a 50 kA bolted fault between 480 Vac and ground, as the current increases, cable insulation catches fire in about 50 ms, and within 100 ms the copper conductor begins to vaporize. In addition to the intense light, the Arc Flash generates extreme heat and an explosive high-pressure wave.

Figure 2.
Damage Caused by Arc-Flash Incident

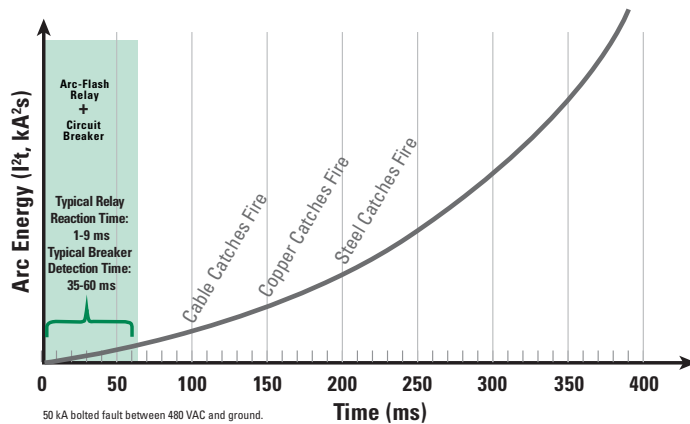

Since light is the earliest detectable indication that an Arc Flash is occurring, virtually all Arc-Flash relays use optical light sensors to detect the arc that is forming. The output of the light sensor is hard-wired to the Arc-Flash relay, which trips a circuit that interrupts the energy supply in the Arc. How quickly this occurs depends on the Arc-Flash relay design. By examining the specifications for several Arc-Flash relays on the market you will find the fastest possible trip times vary from less than one millisecond to about nine milliseconds.

These reaction times are principally a function of the Arc-Flash relay's light sensor input sampling scheme and the design of its trip output circuit. An important aspect of the sensor sampling scheme is avoidance of nuisance tripping (more on light sensing and nuisance trips later). As an example, consider the sampling design of the Littelfuse PGR-8800 Arc-Flash Relay. During normal operation of these devices, light sensor inputs (up to six allowed per relay, up to 24 per system) are sampled every 125 microseconds (i.e., a sample frequency of 8 kHz). Thus, the device will make a positive Arc-Flash detection if light intensity above the trip level is captured at a sensor when the unit samples its related input. The unit counts the number of consecutive samples above the trip level and activates the output when a sufficient number of samples has been counted.

As part of a sensor sampling scheme, a programmable time delay may be used to filter the inputs. This will establish the number of samples needed to trip the relay and thus filter out, for example, photo flashes that could cause unintentional trips. Typically, a programmable time delay filter can be set between zero (instantaneous light detection) and one or two seconds for special application conditions.

After an Arc-Flash relay's input time delay, it takes a certain amount of time for its electronic output to turn on. This time is a function of the type of output relay used. Solid-state outputs (for example, insulated gate bipolar transistors (IGBTs)) are much faster than electromechanical relays and can operate within 200 microseconds.

In the case of the commercial unit mentioned earlier, its default delay of 500 microseconds includes three consecutive samples above the trip threshold and the 200 microsecond turn-on time of its IGBT output. The IGBT turn-on time and the sample interval of 125 microseconds correspond to a minimum trip time (with no time delay filtering) of less than 0.5 ms. The overall sampling time is proportional to the number of sensors used (up to a maximum of six in this case), so the reaction time specification of that Arc-Flash relay is listed as <1 ms. For the fastest response time, the programmable delay should be set to the minimum value consistent with nuisance tripping avoidance.

2. Trip Reliability

Next to reaction time, reliable tripping is the most important characteristic of an Arc-Flash relay, because this ensures mitigation of an arcing fault. Two aspects of reliability should be considered: trip redundancy and system-health monitoring.

Redundant Tripping. Few Arc-Flash relays offer a redundant tripping feature, which is analogous to using both seat belts and air bags in an automobile. It has both primary and secondary trip path logic. The primary path is controlled by the internal microprocessor and its embedded software, and works by activating the coil of the primary trip relay.

The redundant path typically uses a discrete solid-state device that does not go through the microprocessor. Any failure in the primary (microprocessor) path will cause the unit to automatically switch to its redundant path, which activates a shunt-trip relay without delay when a sensor input is above the light detection threshold. A solid-state redundant path is not influenced by programmable settings such as time delay. Some relays provide an option for under-voltage or shunt trips; the redundant path usually operates in shunt mode, thus an under-voltage coil will trip immediately if the microprocessor fails.

An often overlooked advantage of a solid-state trip path compared to a microprocessor-based circuit is the reaction time when the relay is first powered up. It is always best if the relay can remain powered at all times, which is why some relays include options for charging and operating from a battery backup, but consider the situation where the plant (including the Arc-Flash relay) is shut down for maintenance. Wiring mistakes, tools left in hazardous locations, and the regular stresses of powering up all contribute to the risk of an arc-flash on power up. A microprocessor can require 200 ms or more before it is able to start scanning the optical sensors. However, a solid-state trip path can detect an Arc and send a trip signal in as little as 2 ms.

The significance of such redundant type of design is higher reliability, because there is no single point of failure that will incapacitate the system. In addition, there are fail-safe features that alert operators when, for example, the microprocessor fails.

Health monitoring. Health monitoring makes sure the system is in good operating condition and should extend from the light sensors to the output of the Arc-Flash relay trip circuitry. It is often said, "A chain is only as good as its weakest link." Most Arc-Flash relays do not provide on-sensor indication of the scanning and health status of the system. The PGR-8800 is an exception, and its sensors have LED indicators that show if light detection is functioning properly.

Most Arc-Flash relays have some degree of internal health monitoring, but designs can vary considerably. In the case of the PGR-8800, its built-in health monitoring starts right on the sensors. A signal is sent from the relay to the light sensors, where a test light is detected by the sensor and sent back to the relay. In the case of a fiber-optic sensor, this also verifies the entire length of the fiber is not pinched or broken. On-sensor health indication is not a common feature to Arc-Flash relays but can be critical in preventing maintenance work on equipment where protection is inactive since the worker can immediately see that the sensor LED is off. It also has the added benefit of providing rapid fault location.

Following the path of a trip signal from the sensor, internal monitoring must also include the primary and, where

applicable, redundant trip circuit. The next link in the chain is the trip output. In this case, an IGBT switch, which is connected to the breaker trip coil. Low voltage across the IGBT indicates a wiring fault or an error in the trip coil, and a high voltage is a sign of an error in the IGBT switch, both of which are also reported and logged. The IGBT is also thermally protected against overloads, and will turn off if it overheats. However, the thermal protection has a 100 ms delay before acting, meaning that even a dangerously overheated coil will attempt to signal a trip before resuming thermal protection. Thus, complete sensor-to-breaker system-health monitoring is achieved.

Another reliability feature on some Arc-Flash relays is the ability to power the unit with either AC or DC sources. This allows the use of backup battery operation in the event of failure on an independent AC system that powers the unit.

3. Avoidance of Nuisance Tripping

Typically, most Arc-Flash relays use light sensors with fixed detection thresholds set somewhere in the range of 8,000 to 10,000 lux light intensity. In most installations this will avoid nuisance tripping, because an arcing fault produces light intensity exceeding the ambient light level inside a closed switchgear cabinet (See Table 1).

Table 1
Typical Light Levels

Illuminance (lux)	Source
320 - 500	Typical office lighting
1,000	Overcast day or typical TV studio lighting
10,000 - 25,000	Full indirect daylight
32,000 - 130,000	Direct sunlight

Nevertheless, it can be useful to raise the setpoint to help avoid nuisance tripping. For example, opening a switchgear cabinet to bright ambient light, a camera flash, or a worker welding nearby could set off the Arc-Flash relay inadvertently, causing costly downtime.

Some Arc-Flash relays also use a phase-current sensing scheme to help avoid nuisance tripping. One way of handling this is to use current transformer inputs to the Arc-Flash relay's microprocessor (see Figure 3); three CTs are used to measure each of the three phase currents in the system.

If the microprocessor logic receives an input from a light sensor, it checks for a rapidly rising input from the current transformers. If present, it then sends an output signal to the disconnect device.

Figure 3. Phase current transformers (CTs) can be used to help avoid nuisance trips; an Arc-Flash relay trip output requires both a light sensor input and rapidly rising phase current.

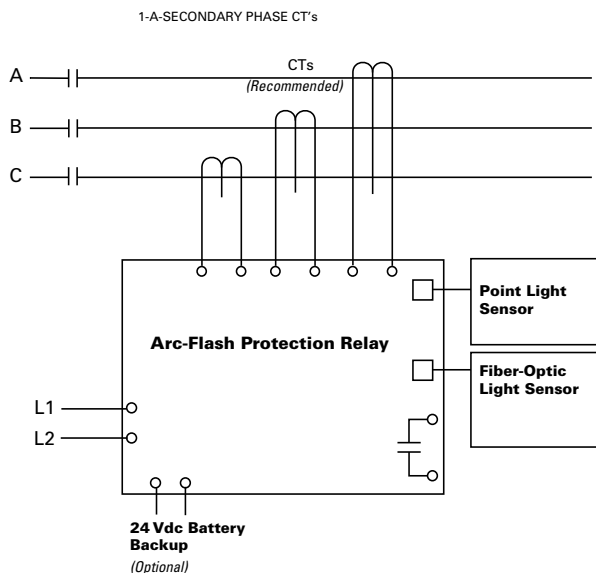

However, using RMS current sensing is not a good way of implementing this feature. A better approach is to use instantaneous current values to detect rapidly rising current that is indicative of an arcing fault. This avoids unnecessary delays in tripping the relay when an Arc Flash occurs. With this method the microprocessor looks for the numerically largest of the three phase currents at any given sample, and compares that to the limits programmed by the user. In addition, delays should be available in the configuration for over-current trips to describe how long the maximum value must stay above the limit for the unit to trip the output. To ensure no negative impact to the protection provided by the Arc-Flash relay, the total trip reaction time should be minimally affected by utilization of CT-current verification. In the case of the PGR-8800 for example, the total trip time is still less than 1 millisecond, subject to the user-selectable time delay setting.

4. Sensor Design and Installation

Most Arc-Flash relay installations utilize multiple fixed-point light sensors near vertical and horizontal bus bars where arcing faults are apt to occur in feeder switchgear cabinets. Sufficient numbers of sensors should be installed to cover all accessible areas, even if policy is to only work on de-energized systems. At least one sensor should have visibility to an arc fault if a person blocks another sensor's field of view. Light sensors may also be installed in other electrical cabinets and on panels that are subject to routine maintenance and repairs, such as those associated with motor control centers. (see Figure 4)

Figure 4. Examples of Arc-Flash relay light sensors installation in switchgear.



In addition to fixed-point sensor inputs, some Arc-Flash relay manufacturers also supply sensors with fiber-optic strands, which have a 360° field of view for detecting light. This allows more flexible positioning of the light sensing locations, as the fiber-optic strands can be looped throughout an enclosure or panel to cover challenging component layouts. Fiber strands ranging from 26 to 65 feet are supplied by various Arc-Flash relay manufacturers, and some also offer interconnection hardware for even longer lengths.

However, long "open" fiber strands designed for light reception over their entire length should be used with caution. Depending on the location of an Arc Flash relative to the far end of such a strand, it's possible that light arriving at the detector end may not be sufficiently bright to cause a relay trip due to attenuation along the fiber length.

Some manufacturers avoid this problem by using interconnecting hardware with hard-wired outputs from the interconnection and detector points back to the Arc-Flash relay. For example the Littelfuse PGR-8800 allows up to six light sensor inputs per relay, and up to four relays can be interconnected to act as a single unit. This means up to 24 light sensor inputs can be used to monitor an electrical equipment configuration.

5. Easy to Use Hardware and Software

Another important factor to consider is ease of use. Some relays may require field assembly, calibration, or advanced configuration before installing. It is critical to consider those extra steps and the capabilities of the operators who will be using the devices. Often, very complicated devices can be misused because of incorrect setup or configuration, which can defeat the purpose of the device altogether.

Figure 5.
Example of an Arc-Flash relay installation in a switchgear cabinet,
along with its fixed-point (A) light sensors, fiber-optic (B) light sensors, and CTs (C).

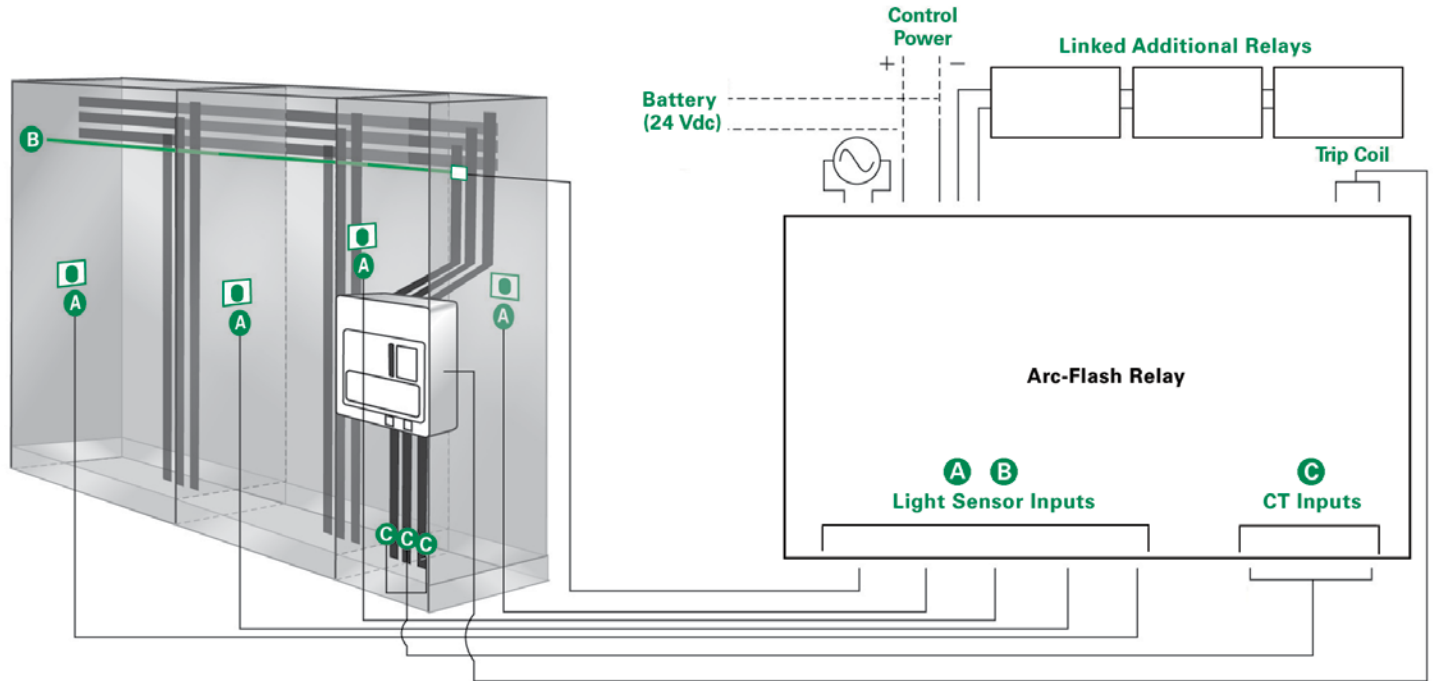

A few Arc-Flash relays have software that provides event logging. To make troubleshooting easier, this software should record the specific sensor that initiated the fault in the data records.

Various data communication interfaces are included on Arc-Flash relays, which can be used to configure the units. For example, some Arc-Flash relays have a USB interface that makes setup easy; even complex scenarios with multiple modules, current sensors, and customized trip levels take only minutes to configure. (See Figure 5) Events can be stored in a log file, which can also be accessed remotely via the USB interface to generate reports and graphs of historical data.

Power system analysis software companies are including Arc-Flash relays in their component libraries. This allows users to perform “what-if” analysis for a variety of relay configurations, circuit variables, and fault conditions.

6. Scalability and flexibility

Several Arc-Flash relay designs allow the interconnection of multiple devices, such as multiple relays each with several sensors. A unique feature of using such a network is the ability of a downstream Arc-Flash event to trip the upstream circuit breaker. This can be very useful where the upstream substation is feeding downstream motor control centers (MCCs). Working on live equipment is very common on MCCs, raising the odds of an Arc-Flash event there.

However, the MCC may be a main-lug-only type, or the main circuit breaker in the MCC may not be able to be remotely tripped. So, there is not a method to remove power if an Arc-Flash event is detected. An Arc-Flash relay installed in the MCC can detect the Arc Flash and tell the networked upstream relay to trip the main circuit breaker feeding the MCC.

The Arc-Flash relays can also be linked in a manner similar to zone-selection interlocking protection devices to provide back-up protection. For example, an Arc-Flash event in the MCC will cause the Arc-Flash relay to send a trip command to the main circuit breaker in the MCC. If it does not trip, the Arc-Flash relay will send a signal to the linked Arc-Flash relay upstream to trip the upstream feeder circuit breaker.

If you plan to interconnect multiple Arc-Flash relays, look for a relay having a versatile link interface with the ability to carry different types of information. The interface should make multiple units respond as “one” to the buttons and inputs. For example, a press on the mode button on one unit will make all connected units change to the service mode or online mode. A versatile interface is helpful when the system is divided into zones—the current sensor is monitoring the feed into the zone, the light sensors are distributed in this zone, and the relay is able to trip the incoming breaker. Typically it is not optimal to trip all breakers just because there is an Arc-Flash event in one zone.

Depending on the relay, other sophisticated capabilities may be offered. In one mode a relay decides for itself whether it should trip, and if it sees both sufficient light and current simultaneously, it trips both its own trip coil output and the link interface. All other connected units then trip their outputs, too. This is useful if several relays are watching zones with the same upstream breaker. No matter which section sees an arc fault, all connected PGR-8800 units will trip simultaneously.

A different mode may make the relays share information from the light and current sensors. An Arc-Flash relay, which sees sufficient light from a local sensor, could use the current inputs from a linked relay, to provide confirmation of an Arc-Flash event. Alternatively, the relay may be set so that multiple relays share information on when a trip is permissible. This is useful if the system is not fully equipped with current sensors, and several zones therefore share one current sensor but have separate breakers. Finally, some relays offer a mode in which the relays, each controlling individual zones, have a common upstream breaker in addition to their own. The relays are then able to trigger a trip on the upstream breaker if, for some reason, the local breaker cannot trip.

Conclusions

Arc-Flash relays are an important adjunct to mitigation devices built into switchgear, such as ducts to channel the explosive forces of an arcing fault away from personnel. Relative to the equipment and personnel they protect, these relays are a very cost-effective insurance policy—able to significantly decrease the risk of Arc Flash. This in turn can prevent costly downtime, equipment replacement, and lawsuit expense. Arc-Flash relays effectively and efficiently minimize these problems and provide additional protection where traditional OCP devices fall short. Still, when selecting an Arc-Flash relay, be sure to examine the functions of the device carefully, and ask the manufacturer to explain how and what it can do in your specific application.

Additional technical information and application data for Littelfuse protection relays, fuses and other circuit protection and safety products can be found on www.littelfuse.com/protectionrelays. For questions, contact our Technical Support Group (800-832-3873). Specifications, descriptions and illustrative material in this literature are as accurate as known at the time of publication, but are subject to changes without notice. All data was compiled from public information available from manufacturers' manuals and datasheets.