

## SE-704 MANUAL

### EARTH-LEAKAGE MONITOR

JANUARY 26, 2011

REVISION 4

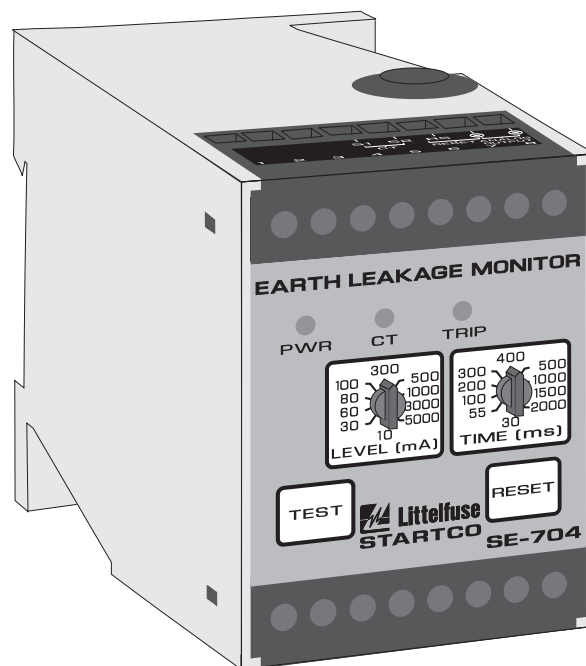

Copyright © 2011 by Littelfuse Startco

All rights reserved.

This page intentionally left blank.

## TABLE OF CONTENTS

	<b>PAGE</b>
Table of Contents .....	i
List of Figures .....	i
List of Tables .....	i
<b>1. General</b> .....	<b>1</b>
<b>2. Operation</b> .....	<b>1</b>
2.1 Configuration-Switch Settings .....	1
2.1.1 Relay Operating Mode .....	1
2.1.2 Filter Selection .....	1
2.1.3 CT Verification .....	1
2.1.4 Reset Mode .....	1
2.1.5 Analog Output .....	1
2.2 Front-Panel Controls .....	1
2.2.1 Earth-Leakage Trip Level .....	1
2.2.2 Earth-Leakage Trip Time .....	1
2.2.3 Reset .....	1
2.2.4 Test .....	3
2.3 Front-Panel Indication .....	3
2.3.1 Power .....	3
2.3.2 Trip .....	3
2.3.3 CT Verification .....	3
2.4 Analog Outputs .....	3
2.5 Self Diagnostics .....	3
<b>3. Installation</b> .....	<b>3</b>
<b>4. SE-704 Compatibility</b> .....	<b>5</b>
<b>5. Technical Specifications</b> .....	<b>10</b>
<b>6. Ordering Information</b> .....	<b>12</b>
<b>7. Warranty</b> .....	<b>12</b>
<b>8. Performance Test</b> .....	<b>13</b>

## LIST OF FIGURES

	<b>PAGE</b>
1. SE-704 Outline and Mounting Details .....	2
2. Typical Connection Diagrams .....	4
3. Typical Three-Phase-Starter Connection .....	4
4. SE-CS30-26 Current Sensor .....	6
5. SE-CS30-70 Current Sensor .....	7
6. SE-CS30-4, SE-CS30-5, and SE-CS30-8 Current Sensors .....	8
7. PMA-55 Panel-Mount Adapter .....	9
8. PMA-60 Panel-Mount Adapter .....	10
9. PGA-0500 Analog Percent Current Meter .....	11
10. Earth-Fault-Test Circuit .....	14

## LIST OF TABLES

	<b>PAGE</b>
1. Trip-Features Comparison .....	5
2. Earth-Fault-Test Record .....	13

## DISCLAIMER

Specifications are subject to change without notice. Littelfuse Startco is not liable for contingent or consequential damages, or for expenses sustained as a result of incorrect application, incorrect adjustment, or a malfunction.

This page intentionally left blank.

## 1. GENERAL

The SE-704 is a microprocessor-based earth-leakage monitor for ac power supply systems that require earth-leakage detection as low as 10 mA. It is uniquely suited for very sensitive earth-fault protection on systems with significant harmonic content. Its output relay can operate in the fail-safe or non-fail-safe mode for undervoltage or shunt-trip applications. The SE-704 has one output relay with isolated normally open and normally closed contacts for use in independent control circuits. Additional features include LED trip and power indication, autoreset or latching trips with front-panel and remote reset, trip memory, test switch, self diagnostics, 0- to 1-mA and 0- to 5-V analog outputs, CT verification with LED indication, digital selector switches, and switch-selectable algorithms for fixed-frequency or variable-frequency applications.

Earth-leakage current is sensed by an SE-CS30-series core-balance earth-fault current transformer. The trip level of the earth-leakage circuit is digital-switch selectable from 10 to 5,000 mA. Trip time is digital-switch selectable from 30 to 2,000 ms.

## 2. OPERATION

### 2.1 CONFIGURATION-SWITCH SETTINGS

See Fig. 1.

#### 2.1.1 RELAY OPERATING MODE

Switch 1 is used to set the operating mode of the output relay. In the fail-safe mode, the output relay energizes when the earth-leakage circuit is not tripped. In the fail-safe mode, non-volatile memory retains the trip status of the SE-704. If tripped, and the supply voltage is cycled, the SE-704 will remain tripped, with the trip relay de-energized and the TRIP LED on, until reset.

In the non-fail-safe mode, the output relay energizes when an earth-leakage trip occurs. In the non-fail-safe mode, trip status is not retained in non-volatile memory.

#### 2.1.2 FILTER SELECTION

Switch 2 is used to select the filtering algorithm for a fixed-frequency (50/60 Hz) or variable-frequency application, for earth-leakage trip levels of 500 mA or less. The peak-detection algorithm is used for settings greater than 500 mA, regardless of the filter selection.

The FIXED FREQUENCY setting uses a DFT filter that allows lower trip levels to be used by rejecting harmonics that can cause nuisance tripping. The VARIABLE FREQUENCY setting uses a peak-detection algorithm with a wider band width for fault detection in variable-frequency drive applications.

#### 2.1.3 CT VERIFICATION

Switch 3 is used to enable CT verification. In the ON position, a trip will occur if the SE-CS30 current sensor is disconnected.

#### 2.1.4 RESET MODE

Switch 4 is used to select autoreset or latching trips. See Section 2.2.3.

#### 2.1.5 ANALOG OUTPUT

Switch 5 is used to select analog-output scaling. Selecting % OF 5A results in full scale output (1 mA or 5 V) when earth-fault current is 5 A. Selecting % OF SETTING results in full scale output when earth-fault current equals the trip-level setting. See Section 2.4.

## 2.2 FRONT-PANEL CONTROLS

### 2.2.1 EARTH-LEAKAGE TRIP LEVEL

The LEVEL (mA) selection switch is used to set the earth-leakage trip level. For earth-leakage detection, the earth-leakage trip level must be substantially below the prospective earth-fault current. To avoid sympathetic tripping, the trip level must be above the charging current of the protected feeder.

### 2.2.2 EARTH-LEAKAGE TRIP TIME

The SE-704 has a definite-time trip characteristic. The TIME (ms) selector switch is used to set the earth-leakage trip time for coordination with upstream and downstream earth-fault devices. Coordination requires the same trip level for all earth-leakage devices in a system and the trip time to progressively increase upstream. The amount of equipment removed from the system will be a minimum if the first earth-leakage device to operate is the one immediately upstream from the fault.

### 2.2.3 RESET

If the Reset Mode switch is in the LATCHING position, a trip remains latched until the RESET switch is pressed or the remote-reset terminals (6 and 7) are momentarily connected. In the non-fail-safe relay operating mode, cycling the supply voltage will also reset the SE-704.

If the Reset Mode switch is in the AUTORESET position, a trip will reset when the fault is removed.

The reset circuit responds only to a momentary closure so that a jammed or shorted switch will not prevent a trip. The front-panel RESET switch is inoperative when the remote-reset terminals are connected.

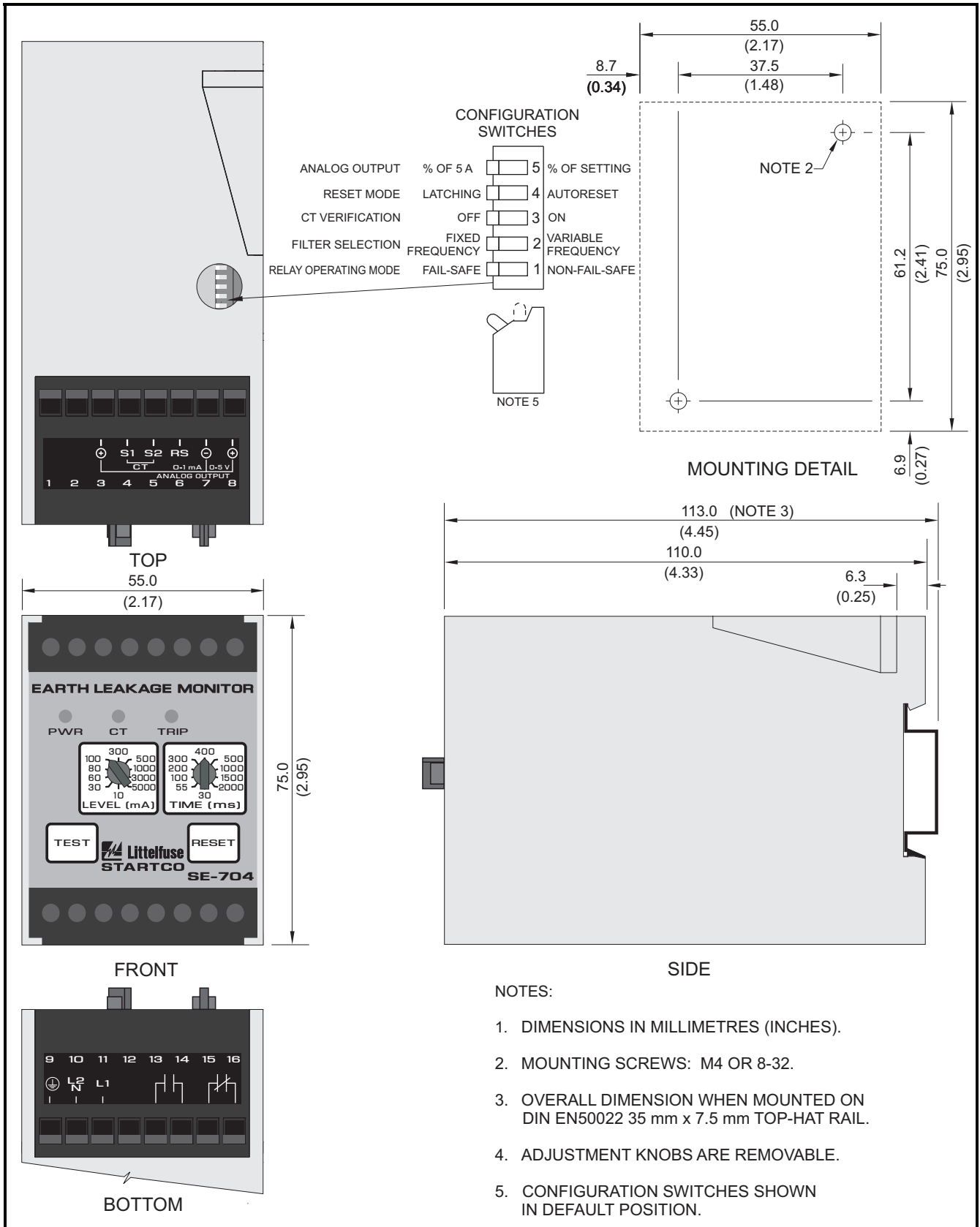

FIGURE 1. SE-704 Outline and Mounting Details.

### 2.2.4 TEST

The TEST switch is used to test the earth-leakage circuit, the indication, and the output relay. When the TEST switch is pressed for one second, a test signal is applied to the earth-leakage-detection circuit, the circuit will trip, the TRIP LED will light, and the output relay will operate.

## 2.3 FRONT-PANEL INDICATION

### 2.3.1 POWER

The green LED labeled PWR indicates presence of supply voltage.

### 2.3.2 TRIP

The red LED labeled TRIP indicates a trip. A solid red LED indicates an earth-leakage trip and a flashing LED indicates a trip initiated by a CT fault. Two fast flashes of the TRIP LED indicate a diagnostic trip. See Section 2.5.

### 2.3.3 CT VERIFICATION

The green LED labeled CT indicates that an SE-CS30 sensor is connected, even if CT verification is disabled.

## 2.4 ANALOG OUTPUTS

The non-isolated, 0- to 1-mA (terminal 3) and 0- to 5-V (terminal 8) analog outputs indicate earth-leakage current sensed by the SE-CS30 series current sensor. The output is linear between zero and full scale. Use a PGA-0500 Analog Percent Current Meter to indicate earth-leakage current. See Figs. 2, 3, and 9.

## 2.5 SELF DIAGNOSTICS

A diagnostic trip is indicated by two fast flashes of the TRIP LED. It can be caused by a problem detected by the watchdog timer, or from an incorrect reading from non-volatile memory. Press RESET or cycle supply voltage. If the problem persists, consult the factory.

## 3. INSTALLATION

**NOTE:** Mounting, terminal-block connections and wiring must conform to applicable local electrical codes. Check all applicable codes prior to installation.

This earth-leakage monitoring system consists of an SE-704 Earth-Leakage Monitor and an SE-CS30-series current sensor connected as shown in Figs. 2 and 3.

An SE-704 can be surface or DIN-rail mounted. See Fig. 1. Panel mounting requires a PMA-55 or PMA-60 Panel-Mount Adapter. See Figs. 7 and 8.

Use terminal 11 (L1) as the line terminal on ac systems or the positive terminal on dc systems. Use terminal 10 (L2/N) as the neutral terminal on ac systems or the negative terminal on dc systems. Connect terminal 9 ( $\oplus$ ) to ground.

Pass the phase conductors through the CT window and position them in the centre of the opening—for 4-wire and single-phase systems also pass the neutral conductor through the CT window, see Figs. 2 and 3. Do not pass earth conductors through the CT window. In applications that require shields or drain wires to pass through the CT window, return them through the CT window before connecting them to earth. Connect the SE-CS30-series current sensor to terminals 4 and 5, connect the shield to terminal 5, and earth terminal 5. See Figs. 4, 5, and 6 for SE-CS30 current-sensor dimensional drawings.

Remove the connection to terminal 9 for dielectric-strength testing—all inputs and outputs have ANSI/IEEE C37.90 surge protection circuits that conduct above 300 Vac.

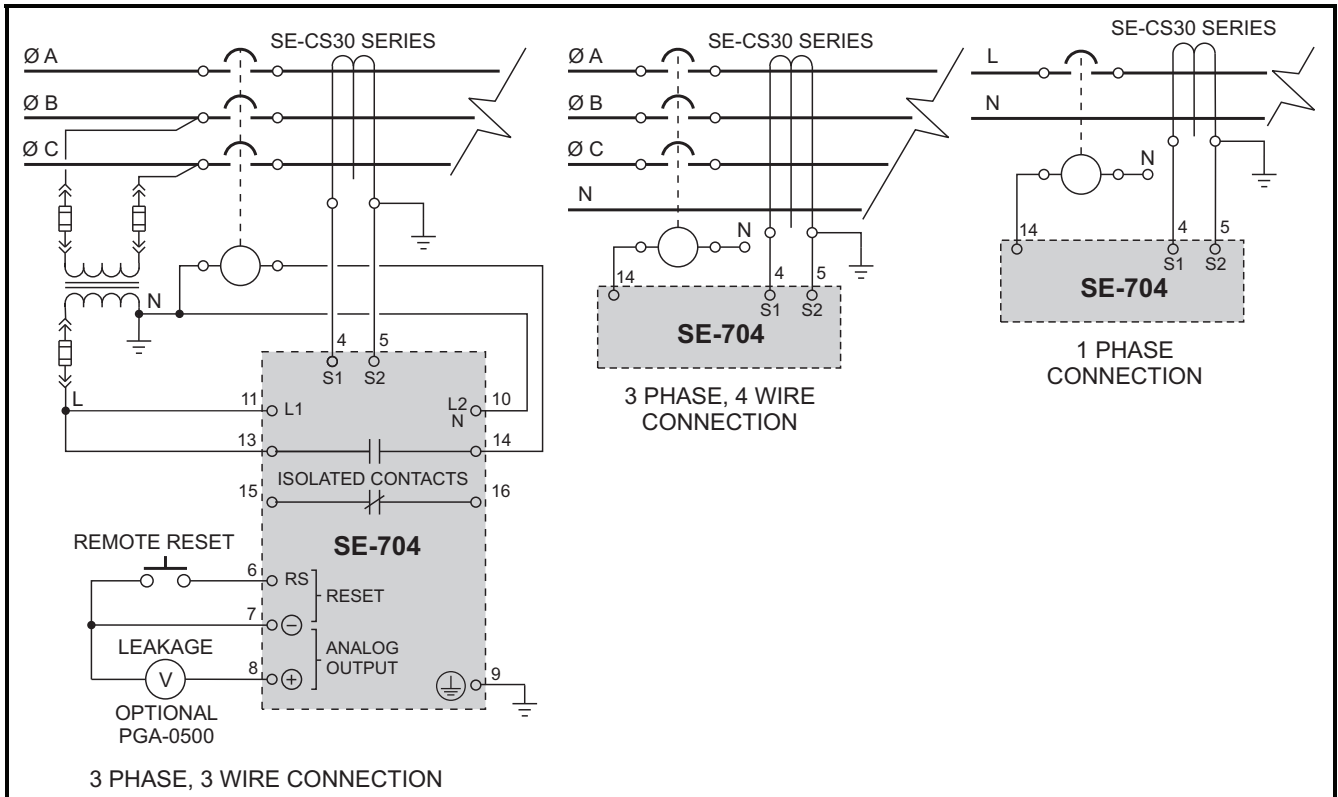

FIGURE 2. Typical Connection Diagrams.

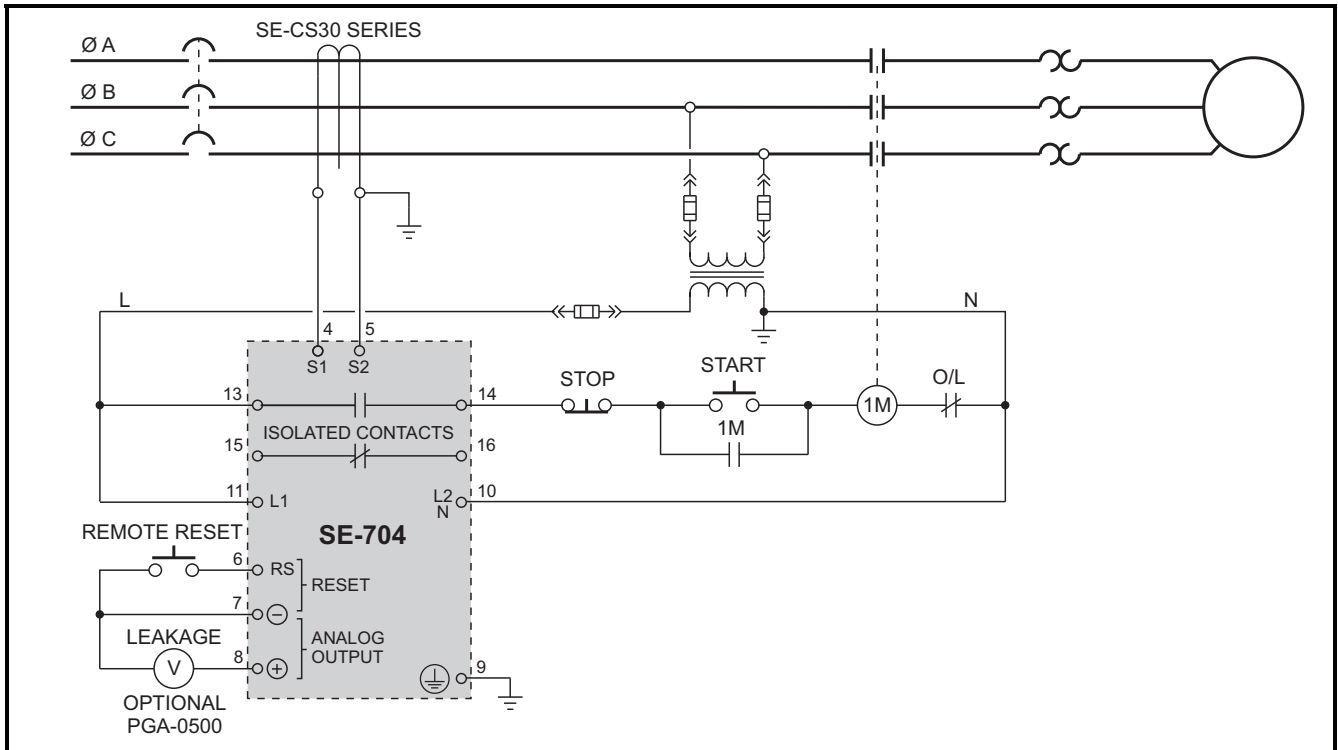

FIGURE 3. Typical Three-Phase-Starter Connection.

#### 4. SE-704 COMPATIBILITY

The current SE-704 has been enhanced with the addition of non-volatile trip memory for the fail-safe relay operating mode. Prior to hardware revision 01, a mechanical flag was used instead of non-volatile trip memory. The current revision of the SE-704 can directly replace previous revision-00 units. The hardware-revision number is listed on the SE-704 model/serial-number label affixed to the SE-704 enclosure. Both generations of SE-704 are compared in Table 1.

The SE-704 was previously available with SE-704-01 120-Vac and SE-704-02 240-Vac control-voltage options. These have been discontinued. An SE-704-0U universal 120/240-Vac/Vdc unit can directly replace an SE-704-01 or SE-704-02.

TABLE 1. TRIP-FEATURES COMPARISON

		HARDWARE REVISION	
		00	≥ 01
LED trip indication		Yes	Yes
Mechanical flag trip indication		Yes	No
Non-volatile trip memory		No	Yes
Device state after supply voltage cycled when tripped (earth fault removed)	Fail-safe	Trip LED: Off Trip relay: Energized Trip flag: Red	Trip LED: On Trip relay: De-energized
	Non-fail-safe	Trip LED: Off Trip relay: De-energized Trip flag: Red	Trip LED: Off Trip relay: De-energized

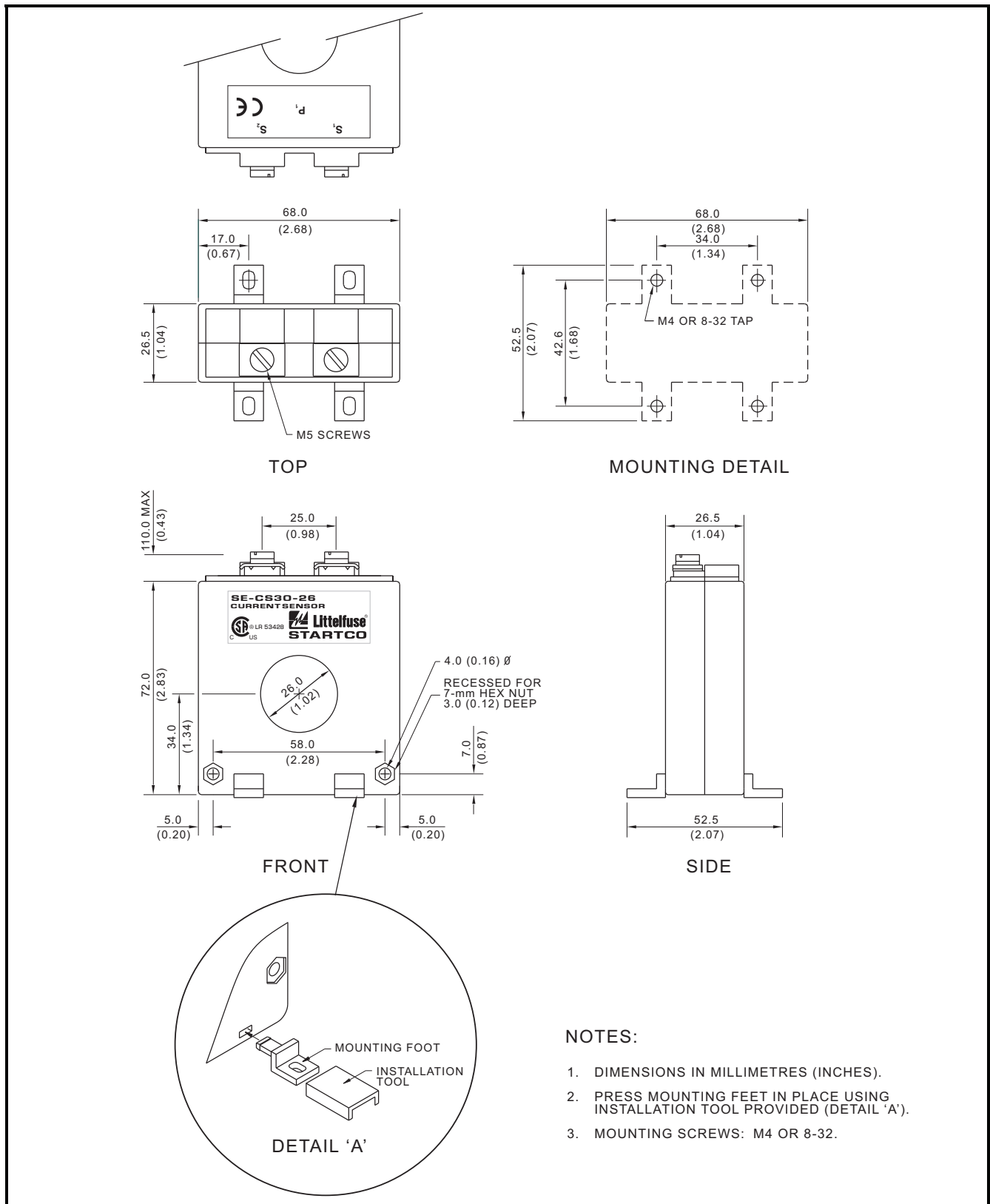

FIGURE 4. SE-CS30-26 Current Sensor.

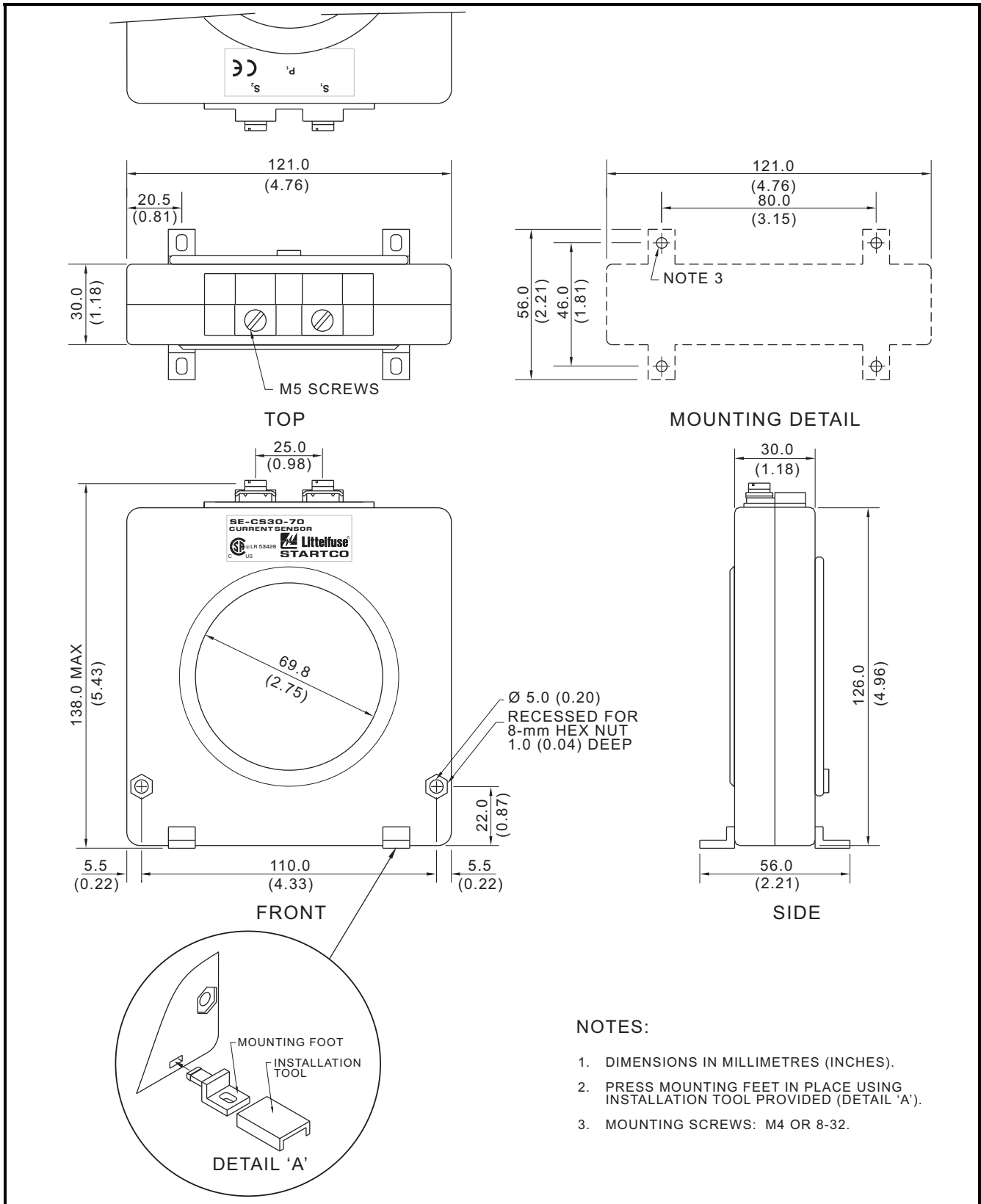

FIGURE 5. SE-CS30-70 Current Sensor.

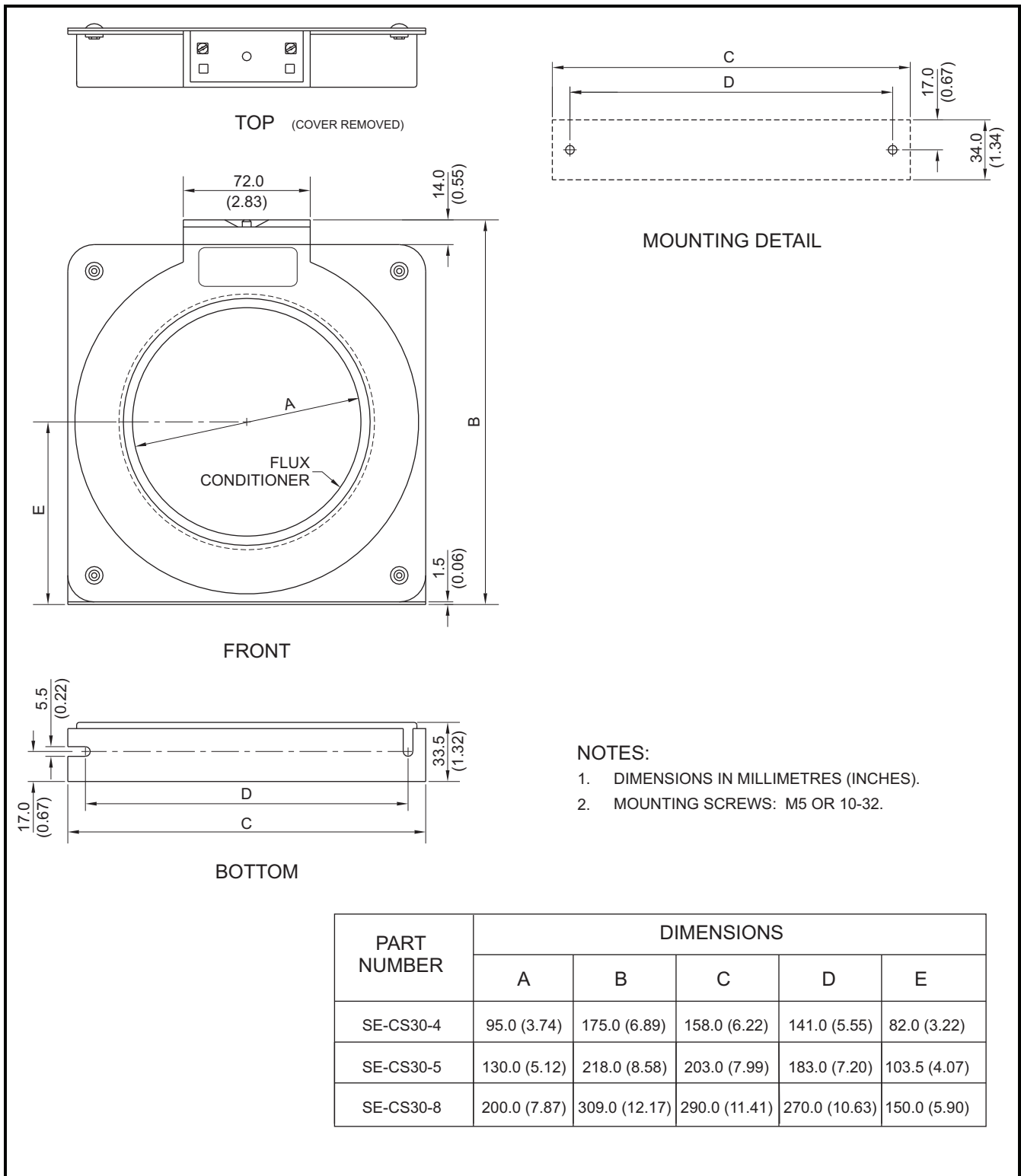

FIGURE 6. SE-CS30-4, SE-CS30-5, and SE-CS30-8 Current Sensors.

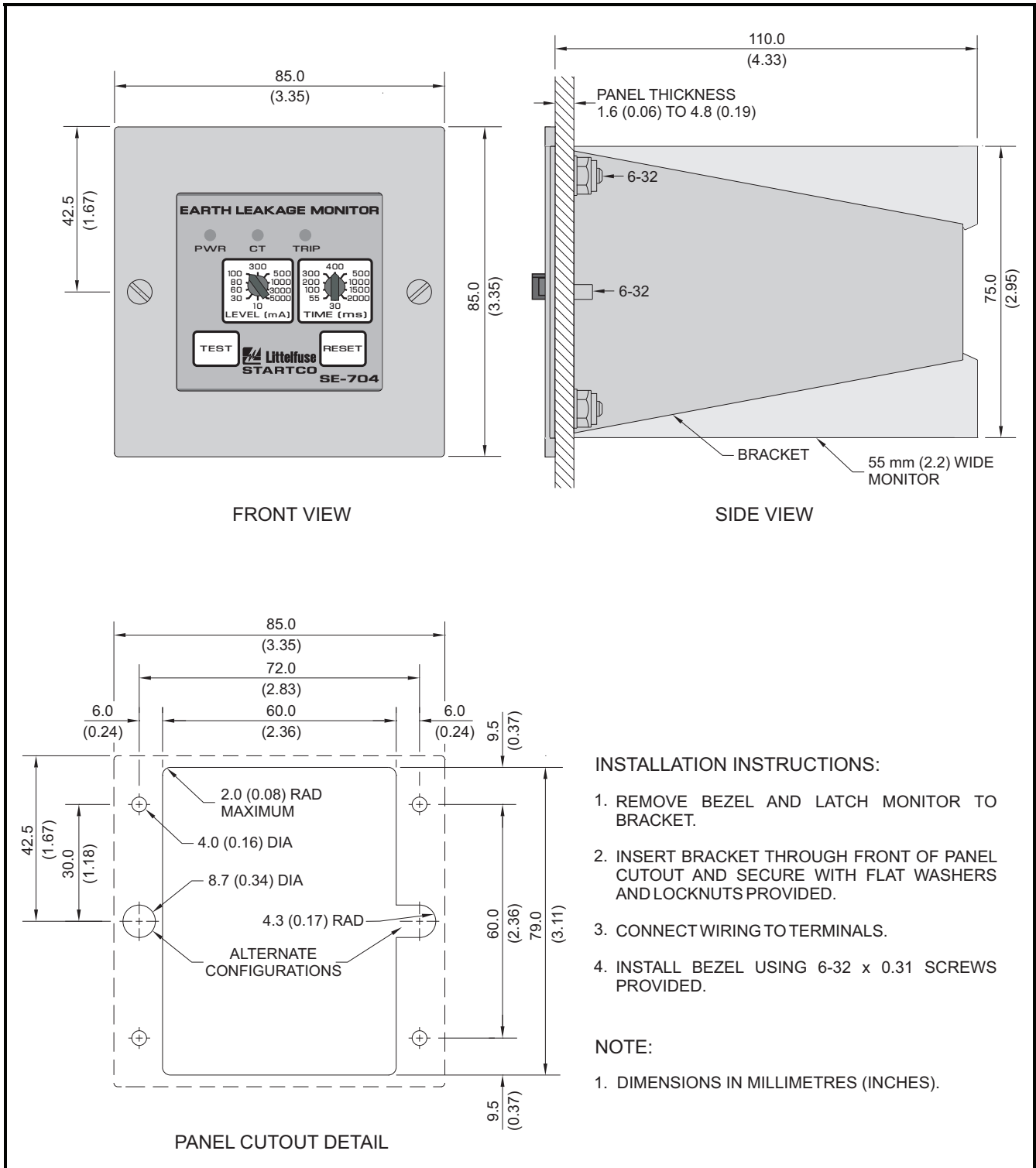

FIGURE 7. PMA-55 Panel-Mount Adapter.

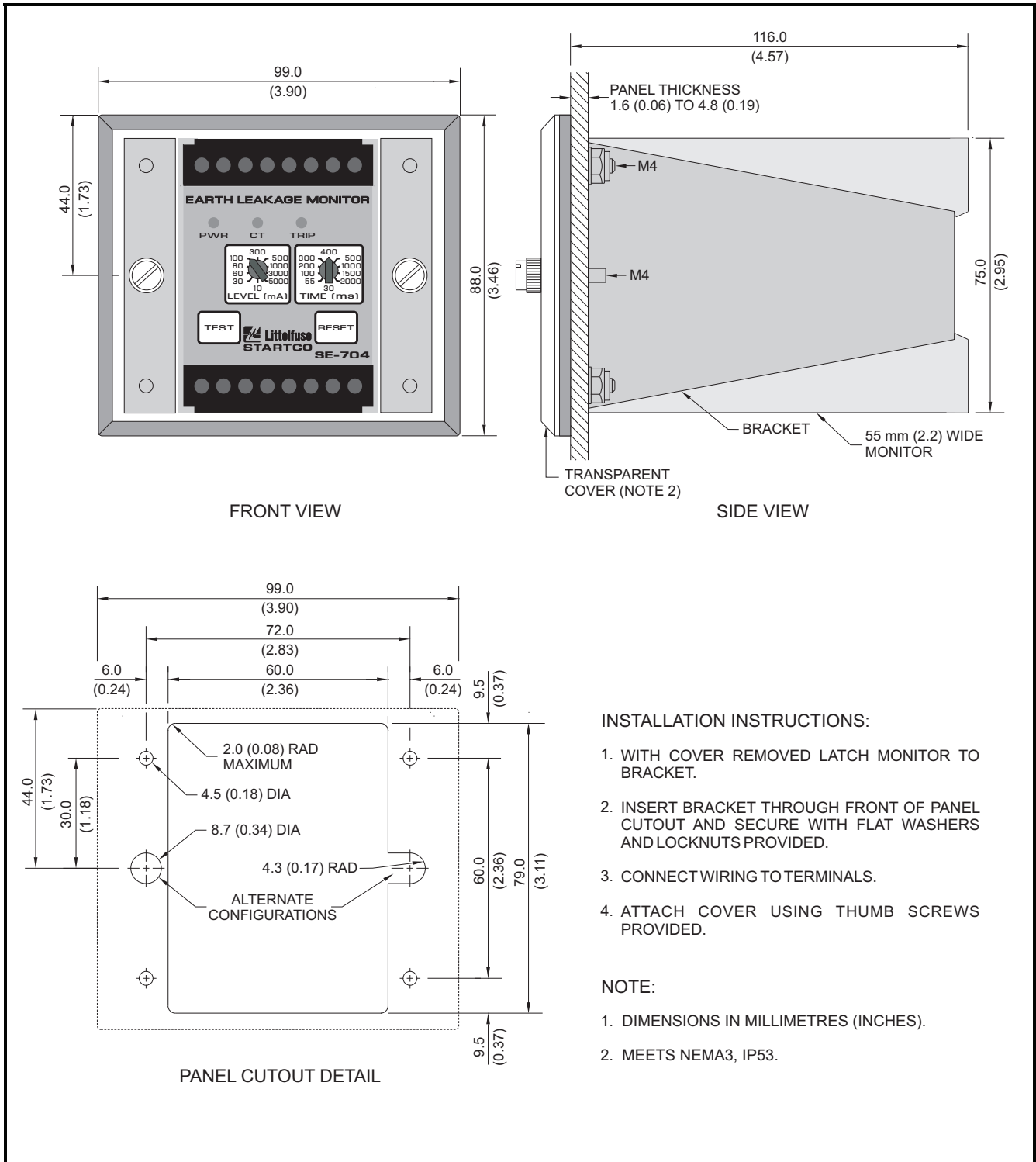

FIGURE 8. PMA-60 Panel-Mount Adapter.

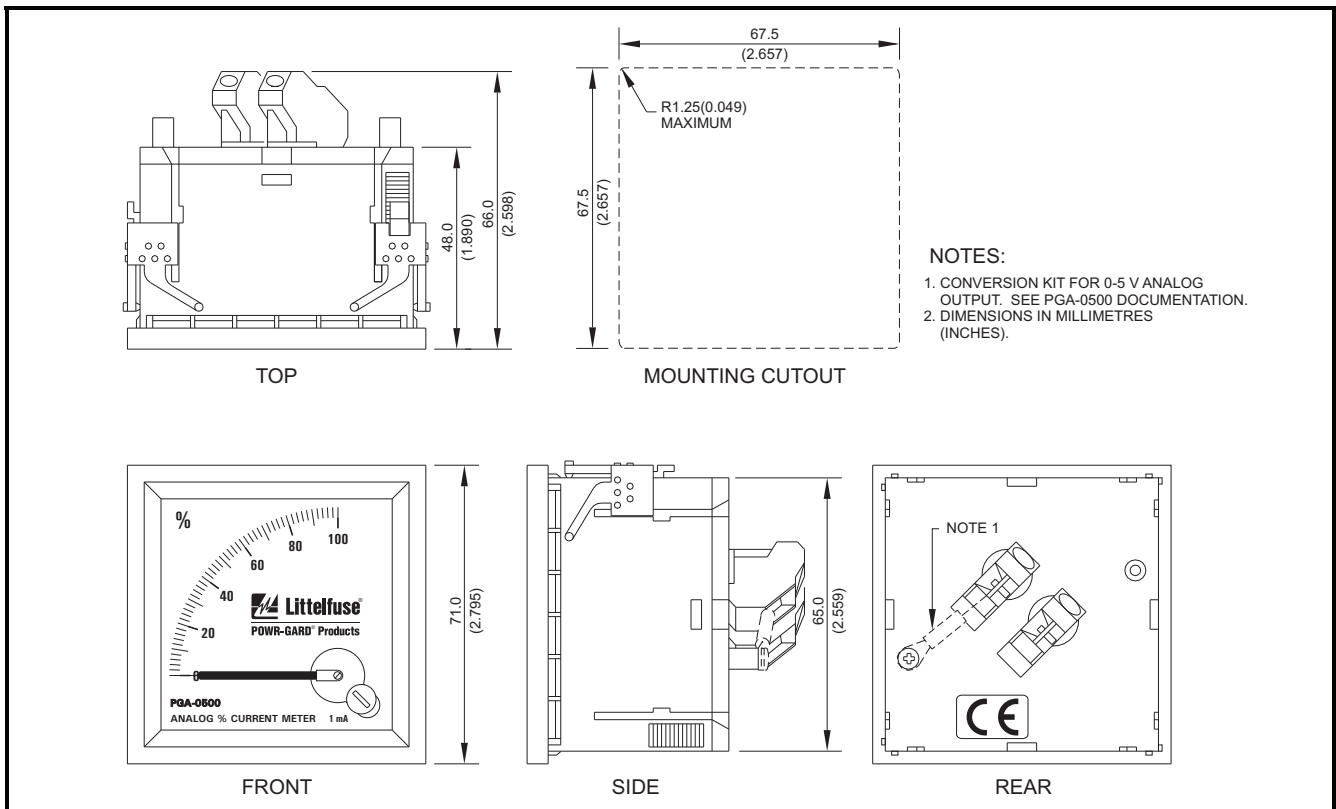

FIGURE 9. PGA-0500 Analog Percent Current Meter.

## 5. TECHNICAL SPECIFICATIONS

### Supply:

0U Option.....	2.5 VA, 120 to 240 Vac, (+20, -55%) 50/60 Hz, 2.0 W, 100 to 240 Vdc, (+20, -25%)
0D Option.....	2.0 W, 12 to 30 Vdc, (+20, -25%)
0T Option.....	2.0 W, 40 to 55 Vdc, (+20, -25%)
03 Option.....	2.5 VA, 24 Vac, (+15%, -40%), 50/60 Hz

Trip-Level Settings.....10, 30, 60, 80, 100, 300,  
500, 1,000, 3,000, and  
5,000 mA

Trip-Time Settings.....30, 55, 100, 200, 300, 400,  
500, 1,000, 1,500, and  
2,000 ms

Accuracies: <sup>(1,2)</sup>

Trip Level: <sup>(3,4)</sup>

1,000 to 5,000 mA .....	+ 2, -10% (60 Hz) + 0, -12% (50 Hz)
60 to 500 mA .....	+ 0, -10%, 10 mA min

30 mA.....	+ 0, -6 mA
10 mA.....	2 mA
Trip Time <sup>(5)</sup> .....	5% of setting, 20 ms min

### Input:

Algorithms <sup>(6)</sup> .....	DFT Digital or Peak
DFT 3 dB Frequency Response .....	32 to 86 Hz (<1,000 mA)
Peak 3 dB Frequency Response .....	20 to 420 Hz (<1,000 mA)
Peak 3 dB Frequency Response .....	20 to 120 Hz (≥1,000 mA)
CT .....	SE-CS30-Series Current Sensor
CT Detection.....	Open-Circuit Detection
Thermal Withstand:	
Continuous.....	25 A Earth-Fault Current
1-Second .....	400 A Earth-Fault Current

### NOTES:

- <sup>(1)</sup> Detection limit (A) = (setting in mA – 5,610)/-1.4.
- <sup>(2)</sup> At 50 or 60 Hz unless otherwise noted.
- <sup>(3)</sup> SE-Cs30-series current sensor included.
- <sup>(4)</sup> Maximum lead resistance of 2 Ω.
- <sup>(5)</sup> Trip Time at 3 x trip-level setting.
- <sup>(6)</sup> Peak algorithm for trip-level setting ≥ 1,000 mA

Analog Output:

Modes..... % of 5 A or % of Trip-Level Setting

Range:

Terminal 3..... 0 to 1 mA  
Terminal 8..... 0 to 5 Vdc

Output Impedance:

Terminal 3..... 4,970 Ω  
Terminal 8..... 220 Ω

Output Relay:

Contact Configuration ..... Isolated N.O. and N.C.  
Operating Mode..... Fail-Safe or Non-Fail-Safe  
CSA/UL Contact Rating.... 8 A General Use, 250 Vac,  
8 A Resistive, 30 Vdc

Supplemental Contact Ratings:

Carry Current ..... 8 A, maximum  
Break:  
30 Vdc..... 240 W Resistive,  
170 W Inductive (L/R=7 ms)  
120 Vdc ..... 24 W Resistive,  
17 W Inductive (L/R=7 ms)  
ac..... 2,000 VA Resistive,  
875 VA Inductive  
(PF = 0.4)  
Subject to maximums of 8 A and  
250 Vac/30 Vdc or 200 mA at 120 Vdc

Operating Mode..... Latching or Autoreset

Reset..... Front-Panel Switch and  
Remote N.O. Contact

Functional Test ..... Front-Panel Switch

Terminals ..... Wire Clamping,  
24 to 12 AWG  
(0.2 to 2.5 mm<sup>2</sup>) conductors

Dimensions:

Height..... 75 mm (3.0")  
Width..... 55 mm (2.2")  
Depth..... 115 mm (4.5")

Shipping Weight..... 0.45 kg (1 lb.)

Environment:

Operating Temperature ..... -40°C to 60°C  
Storage Temperature..... -55°C to 80°C  
Humidity..... 85% Non-Condensing

Surge Withstand..... ANSI/IEEE 37.90.1-1989  
(Oscillatory and Fast  
Transient)

EMC Tests:

Verification tested in accordance with EN 50263:2000  
Electrostatic Discharge ..... IEC 61000-4-2, EN 61000-4-2,  
6 kV Contact Discharge,  
8 kV Air Discharge

Radiated RF ..... IEC 61000-4-3, EN 61000-4-3  
10 V/m, 80-1000 MHz,  
80% AM (1 kHz)  
10 V/m, 900 MHz,  
200 Hz Pulse Modulated

Fast Transient ..... IEC 61000-4-4, EN 61000-4-4  
±2 kV Common Mode,  
±1 kV Differential Mode

Surge Immunity ..... IEC 61000-4-5, EN 61000-4-5  
±2.0 kV Common Mode,  
±1.0 kV Differential Mode

Conducted RF ..... IEC 61000-4-6, EN 61000-4-6  
10Vrms, 0.15-80 MHz,  
80% AM (1 kHz)

Magnetic Field..... IEC 61000-4-8, EN 61000-4-8  
50 Hz, 30 A/m (continuous)  
50 Hz, 300 A/m  
(1 to 3 seconds)

Voltage Interruption ..... IEC 255-22-11, EN 60255-11  
100% for 2, 5, 10, 20, 50,  
100, & 200 ms

MHz Burst ..... IEC 255-22-1, EN 60255-22-1  
1 kV Differential Mode,  
2.5 kV Common Mode

RFI Compliance..... FCC Part 15, Subpart B,  
Class A – Unintentional  
Radiators

Certification ..... CSA, Canada and USA



Australia



CE, European Union



Complies to IEC 61010-1:2001 (2<sup>nd</sup> Edition);  
EN 61010-1:2001 (2<sup>nd</sup> Edition) Safety Requirements  
for Electrical Equipment for Measurement, Control,  
and Laboratory Use – Part 1.

## 6. ORDERING INFORMATION

SE-704-0

- U Universal 120/240-Vac/Vdc Supply
- D 12/24-Vdc Supply
- T 48-Vdc Supply
- 3 24-Vac Supply

SE-CS30-26 .....Current Sensor,  
26.0 mm (1.02") Window

SE-CS30-70 .....Current Sensor c/w Flux Conditioner,  
69.8 mm (2.75") Window

SE-CS30-4 .....Current Sensor c/w Flux Conditioner,  
95.0 mm (3.74") Window

SE-CS30-5 .....Current Sensor c/w Flux Conditioner,  
130.0 mm (5.12") Window

SE-CS30-8 .....Current Sensor c/w Flux Conditioner,  
200.0 mm (7.87") Window

PGA-0500 .....Analog Percent Current Meter

PMA-55 .....Panel-Mount Adapter, NEMA 1

PMA-60 .....Panel-Mount Adapter, NEMA 3, IP53

PMA-3 .....Adapter Plate, GEC/MCGG

PMA-6 .....Adapter Plate, FPL-GFRM

PMA-15 .....Adapter Plate, MGFR

Consult factory for custom mounting adapters.

## 7. WARRANTY

The SE-704 Earth-Leakage Monitor is warranted to be free from defects in material and workmanship for a period of five years from the date of purchase.

Littelfuse Startco will (at Littelfuse Startco's option) repair, replace, or refund the original purchase price of an SE-704 that is determined by Littelfuse Startco to be defective if it is returned to the factory, freight prepaid, within the warranty period. This warranty does not apply to repairs required as a result of misuse, negligence, an accident, improper installation, tampering, or insufficient care. Littelfuse Startco does not warrant products repaired or modified by non-Littelfuse Startco personnel.

