

SE-325 MANUAL

NEUTRAL-GROUNDING-RESISTOR MONITOR

JANUARY 25, 2012

REVISION 11

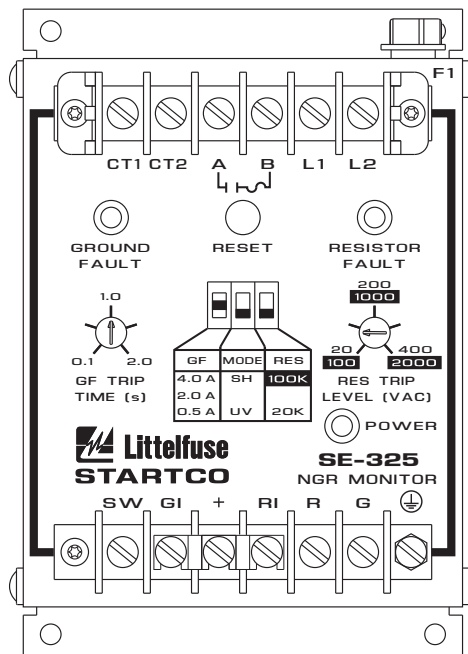

Copyright © 2012 by Littelfuse Startco

All rights reserved.

This page intentionally left blank.

TABLE OF CONTENTS

	PAGE
1. General	1
1.1 Modern Resistance-Grounded Systems	1
1.2 SE-325 NGR Monitoring.....	1
2. Operation	1
2.1 Settings	1
2.1.1 GF Trip Time.....	1
2.1.2 GF	1
2.1.3 Mode	2
2.1.4 RES	2
2.1.5 RES Trip Level.....	2
2.2 Indication and Reset	2
2.3 Fusing	2
3. Installation	3
3.1 SE-325	3
3.2 Ground-Fault CT	5
3.3 Sensing Resistor	6
3.4 Isolated-Ground Connection.....	15
3.5 Overhead Lines	15
3.6 Remote Operation	15
3.7 Ground-Fault Testing.....	15
4. Technical Specifications	15
4.1 SE-325	15
4.2 Sensing Resistors.....	16
4.3 Current Transformer.....	16
5. Ordering Information	17
6. Warranty	17
7. Test Procedures	18
7.1 Ground-Fault Performance Test	18
7.2 Resistor-Fault Tests.....	19
7.2.1 Open Test	19
7.2.2 Voltage Test	19
7.3 Sensing-Resistor Test.....	19

LIST OF FIGURES

FIGURE		PAGE
1	Typical Application	3
2	SE-325 Outline and Mounting Details.....	4
3	Current Transformers.....	5
4	ER-600VC Sensing Resistor	6
5	SE-MRE-600 Moisture-Resistant Enclosure.....	7
6	SE-MRE-600 with installed ER-600VC.....	8
7	ER-5KV Sensing Resistor	9
8	ER-5WP Sensing Resistor	10
9	ER-15KV Sensing Resistor	11
10	ER-25KV Sensing Resistor	12
11	RK-302 Remote Indication and Reset	13
12	RK-325 Remote Indication-and-Reset Assembly	13
13	RK-325I Remote Indication Assembly.....	14
14	RK-13 Relay Interface Module	14
15	Ground-Fault-Test Circuits.....	18

LIST OF TABLES

TABLE		PAGE
1	Settings For Typical Systems	2
2	Ground-Fault-Test Record.....	18

DISCLAIMER

Specifications are subject to change without notice. Littelfuse Startco is not liable for contingent or consequential damages, or for expenses sustained as a result of incorrect application, incorrect adjustment, or a malfunction.

This page intentionally left blank.

1. GENERAL

1.1 MODERN RESISTANCE-GROUNDED SYSTEMS

A high-resistance-grounded system uses a neutral-grounding resistor (NGR) with a low let-through current to limit ground-fault current. This is an improvement over low-resistance- or solidly grounded systems because, in those systems, a ground-fault flash hazard exists and a ground fault can result in substantial point-of-fault damage. High-resistance grounding eliminates these problems and modern ground-fault protection operates reliably at these levels. Furthermore, the probability of an arc-flash incident is significantly reduced in a high-resistance-grounded system.

NGR selection depends on system charging current and whether the system is an alarm-only or a tripping system. Alarm-only systems are usually restricted to system voltages up to 5 kV with NGR let-through currents of 5 A or less. Occasionally, alarm-only systems up to 15 kV and up to 10 A are used; however, they are not common because a ground fault on such a system tends to escalate to a phase-to-phase fault before the ground fault can be located and cleared.

System charging current is the capacitive current that flows to ground when a bolted ground fault occurs. This current can be calculated or measured. For small systems, the magnitude of charging current can be conservatively estimated as ½ A per 1,000 kVA on low-voltage systems and 1 A per 1,000 kVA on medium-voltage systems.

In an alarm-only system or in a tripping system without selective coordination, choose an NGR with a let-through current larger than the system charging current and set the pick-up current of ground-fault devices at or below 50% of the NGR let-through current.

In a tripping system with selective coordination, use ground-fault devices with a definite-time characteristic to achieve time coordination. Use the same pick-up current for all ground-fault devices—this value must be larger than the charging current of the largest feeder. Select an NGR with a let-through current between five and ten times the pick-up current of the ground-fault devices.

Do not use a grounding transformer with a low-voltage resistor:

- The combined cost of a transformer and a low-voltage resistor is more than the cost of a resistor rated for line-to-neutral voltage.
- A transformer saturated by a ground fault through a rectifier can make ground-fault protection inoperative.
- Transformer inrush current up to twelve times rated current can cause a ground-fault voltage larger than expected.
- A parallel transformer winding makes it difficult to monitor NGR continuity.
- A transformer can provide the inductance necessary to cause ferroresonance if the NGR opens.

Following these guidelines will reduce the flash hazard, reduce point-of-fault damage, achieve reliable ground-fault protection, and ensure a stable system not subject to ferroresonance.

1.2 SE-325 NGR MONITORING

The SE-325 is a neutral-grounding-resistor monitor for resistance-grounded systems up to 25 kVac. It measures current in a transformer or generator neutral, neutral-to-ground voltage, and continuity of the neutral-grounding resistor. The SE-325 coordinates these three measurements to detect a failed NGR or a ground fault and provides one output contact for shunt or undervoltage operation in a main-breaker trip circuit. Trips are latched and indicated by LED's.

Ground-fault current is sensed by a CT200 window-type current transformer. Either CT input can be grounded to meet electrical codes. A trip level of 0.5, 2.0, or 4.0 A is switch selectable for use with a 5-, 15-, or 25-A grounding resistor. Trip time is adjustable from 0.1 to 2.0 seconds.

Neutral-to-ground voltage and continuity of the neutral-grounding resistor are continuously measured through an ER-series external sensing resistor connected to the neutral. A resistor fault will be detected if ground-fault current is not detected and neutral-to-ground voltage exceeds the trip-level setting, or if NGR resistance exceeds the trip resistance. A resistor-fault hold-off circuit prevents nuisance trips in alarm-only systems.

For additional information on neutral-grounding-resistor monitoring, see “Monitoring Neutral-Grounding Resistors – An Update” at www.startco.ca.

2. OPERATION

2.1 SETTINGS

2.1.1 GF TRIP TIME

Ground-fault trip time is adjustable from 0.1 to 2.0 seconds. Time-coordinated ground-fault protection requires this setting to be longer than the trip times of downstream ground-fault devices.

For the extended ground-fault trip-time option (Option T), trip time is adjustable from 0.1 to 5.0 seconds.

2.1.2 GF

The ground-fault-circuit trip level is 0.5, 2.0, or 4.0 A when current is sensed with a CT200 current transformer. Since the ground-fault-circuit trip level should not be greater than 20% of the grounding resistor let-through current, these levels are appropriate for use with 5-, 15-, or 25-A grounding resistors. See Table 1. For other applications, the trip level of the ground-fault circuit is 0.25, 1.0, or 2.0% of the primary rating of the 5-A-secondary current transformer.

2.1.3 MODE

In the shunt-trip mode (SH), the output relay energizes and its contact closes if a resistor-fault or ground-fault trip occurs. The shunt-trip mode is not fail-safe because shunt-trip devices do not operate if supply voltage fails.

In the undervoltage mode (UV), the output relay energizes and its contact closes if the resistor-fault and ground-fault circuits are not tripped. The undervoltage mode is referred to as fail-safe because undervoltage devices release if supply voltage fails.

2.1.4 RES

This switch setting must correspond to the resistance of the external sensing resistor. For the ER-600VC and ER-5KV, select 20K. For the ER-15KV and ER-25KV, select 100K.

2.1.5 RES TRIP LEVEL

Neutral-to-ground trip voltage is adjustable from 20 to 400 Vac with a 20-kΩ sensing resistor, and 100 to 2,000 Vac with a 100-kΩ sensing resistor. To prevent false resistor-fault trips, the RES TRIP LEVEL should be set higher than the voltage across the neutral-grounding resistor when neutral-to-ground current is equal to the operating value of the ground-fault circuit. Typical values for 5-, 15-, and 25-A tripping systems are shown in Table 1. For other systems, refer to the NGR Monitor Set-Point Assistant at www.startco.ca.

2.2 INDICATION AND RESET

The blue POWER LED indicates that the internal power supply is on. Red LED's indicate ground-fault and resistor-fault trips. When a trip occurs, the SE-325 remains latched until Reset is pressed or supply voltage is cycled. Terminals are provided for remote indication and reset as shown in Fig. 1.

For the non-latching option (Option N), the SE-325 resets when the fault clears.

2.3 FUSING

The output contact is protected by fuse F1 (4.0 A, time delay).

TABLE 1. SETTINGS FOR TYPICAL SYSTEMS

System Voltage (Volts)	Neutral-Grounding Resistor		Sensing Resistor		Ground-Fault Trip Level (Amperes)	ResTrip Level (Volts)
	Let Through (Amperes)	Resistance (Ohms)	Model	Resistance (Ohms)		
480	5	55	ER-600VC	20,000	0.5	30
600	5	69	ER-600VC	20,000	0.5	40
2,400	5	277	ER-5KV	20,000	0.5	140
4,160	5	480	ER-5KV	20,000	0.5	240
480	15	18	ER-600VC	20,000	2.0	40
600	15	23	ER-600VC	20,000	2.0	50
2,400	15	92	ER-5KV	20,000	2.0	190
4,160	15	160	ER-5KV	20,000	2.0	320
7,200	15	277	ER-15KV	100,000	2.0	600
14,400	15	554	ER-15KV	100,000	2.0	1,100
7,200	25	166	ER-15KV	100,000	4.0	700
14,400	25	332	ER-15KV	100,000	4.0	1,400
25,000	25	577	ER-25KV	100,000	4.0	2,000

3. INSTALLATION

3.1 SE-325

SE-325 outline and mounting details are shown in Fig. 2. Typical connections are shown in Fig. 1. Connect supply voltage to L1 and L2. For a 120-Vac supply, connect supply neutral to L2. For a direct-current supply, connect supply negative to L2. Connect chassis-bonding terminal ⊕ to ground.

Connect contact terminals A and B as required.

Face-plate LED's are driven in series with remote-indication LED's. When remote-indication LED's are not used, terminals GI, +, and RI must be connected for the face-plate LED's to operate. These jumpers are installed at the factory.

Install the upper terminal-block cover to prevent inadvertent contact with line terminals.

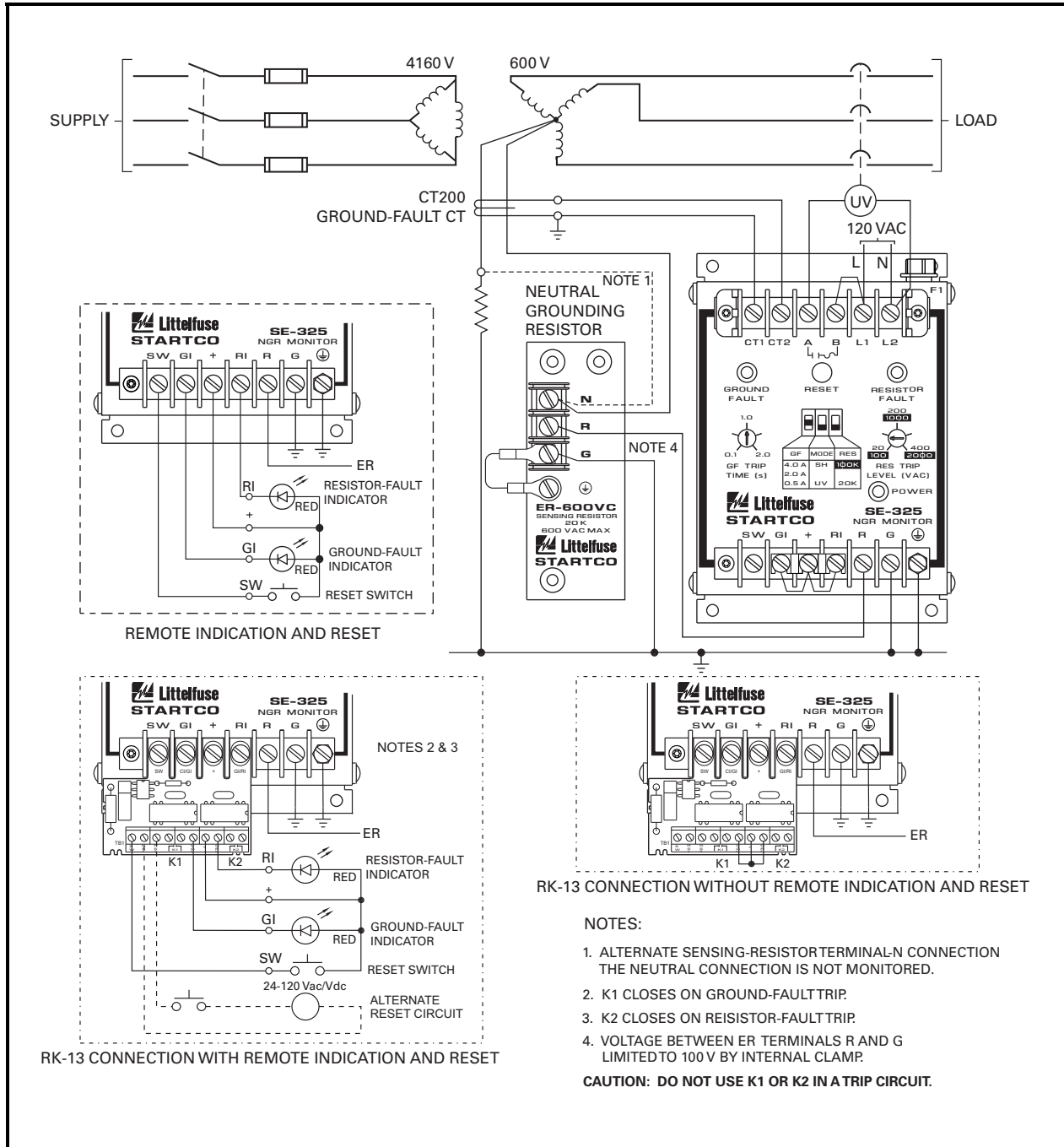

FIGURE 1. Typical Application.

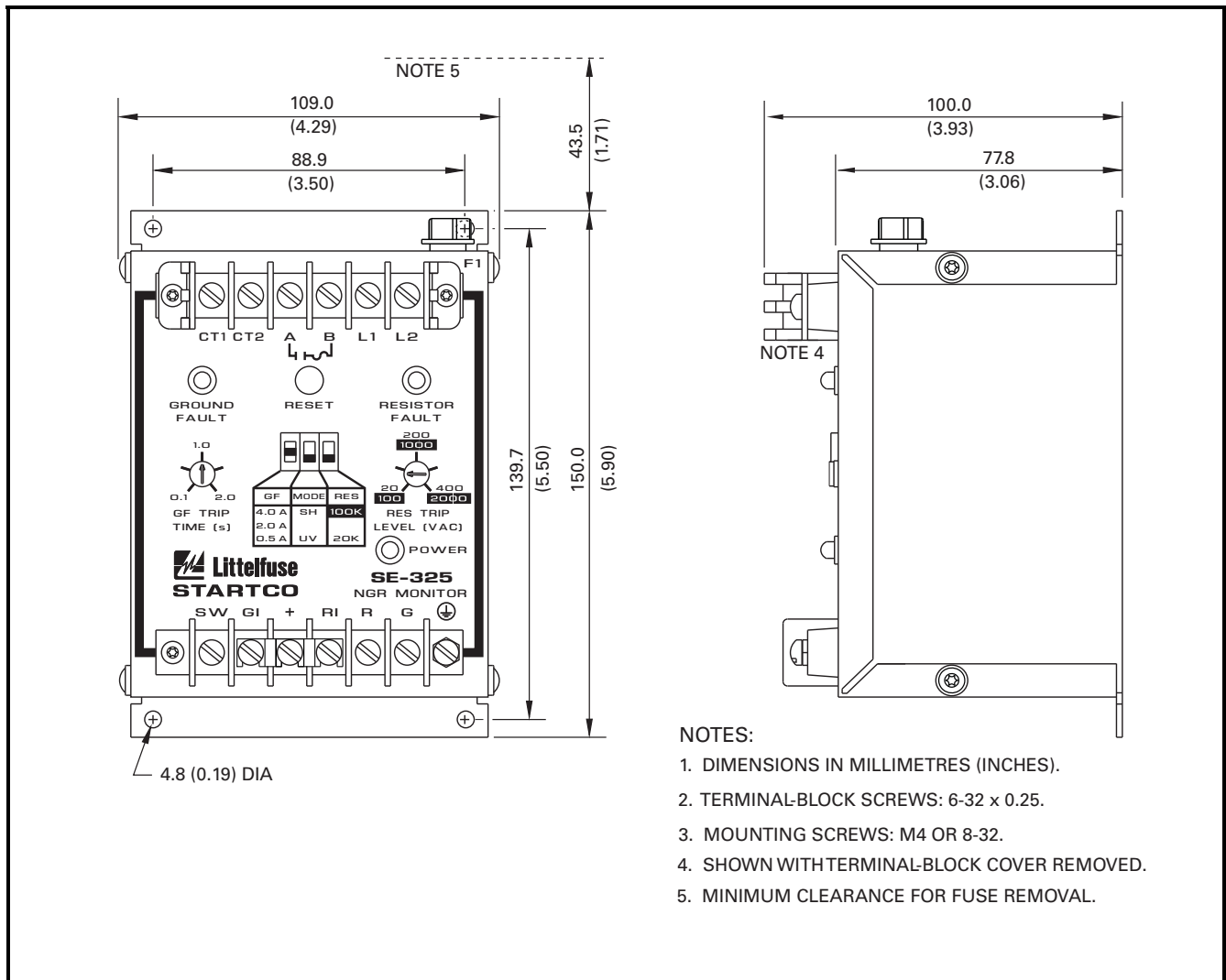

FIGURE 2. SE-325 Outline and Mounting Details.

3.2 GROUND-FAULT CT

Outline and mounting details for CT200 and CT200L current transformers are shown in Fig. 3. Ground-fault-CT connections and the typical ground-fault-CT location are shown in Fig. 1.

Connect the secondary of the ground-fault CT to SE-325 terminals CT1 and CT2. The CT connection to the SE-325 is not polarity sensitive. Ground one side of the CT secondary. For electrically noisy environments or lead lengths in excess of 10 m (30 ft), use shielded, twisted-pair cable.

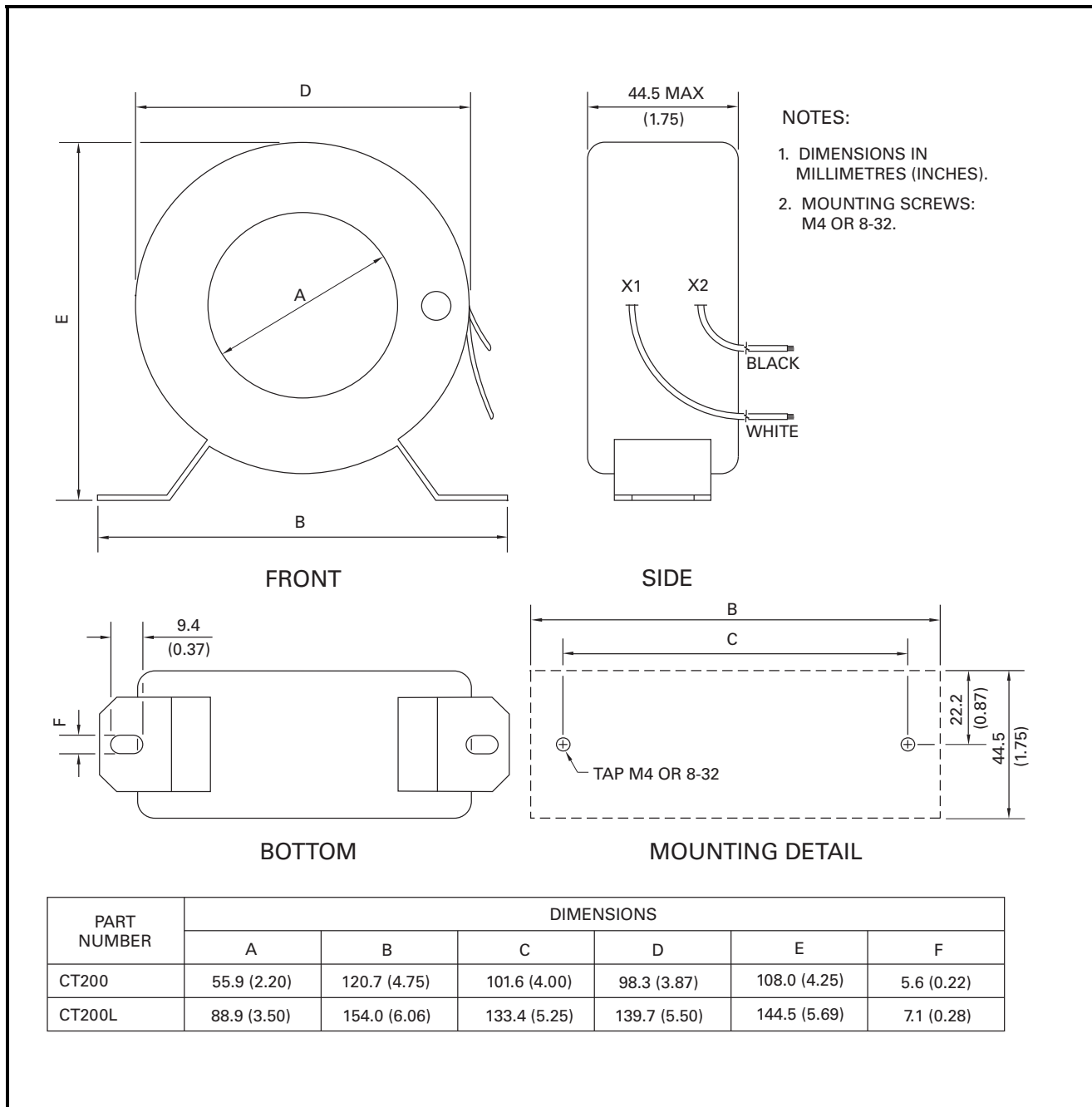

FIGURE 3. Current Transformers.

3.3 SENSING RESISTOR

Outline and mounting details for ER-600VC, ER-5KV, ER-15KV, and ER-25KV sensing resistors are shown in Figs. 4, 5, 6, and 7. Locate the NGR and the sensing resistor near the transformer or generator. When located outdoors, a sensing resistor must be installed in a suitable enclosure. An optional SE-MRE-600 Moisture Resistant Enclosure is available for applications which may expose an ER-600VC to moisture. See Figures 5 and 6. The ER-5WP (shown in Fig. 8) is an ER-5KV with moisture-resistant terminal covers. The ER-15KV and ER-25KV include moisture resistant terminal covers. Use suitable water-tight fittings. Ground sensing-resistor terminal G. Pass the sensing-resistor-to-neutral conductor and the NGR-to-neutral conductor through the ground-fault-CT window as shown in Fig. 1.

Separately connect sensing-resistor terminal N and the NGR to the neutral to include neutral connections in the monitored loop. If a ground fault in the sensing-resistor conductor is unlikely, a minimal loss of protection will result if it does not pass through the ground-fault-CT window.

CAUTION: Voltage at terminal N rises to line-to-neutral voltage when a ground fault occurs. The same clearances are required for sensing resistors as for NGR's.

NOTE: The neutral-to-sensing-resistor connection is not a neutral conductor as defined in Canadian Electrical Code Section 10-1108 and National Electrical Code Section 250.36(B). It is not required to be 8 AWG or larger. Since current through this conductor is always less than 150 mA, a 14 AWG conductor insulated to the system voltage is sufficient.

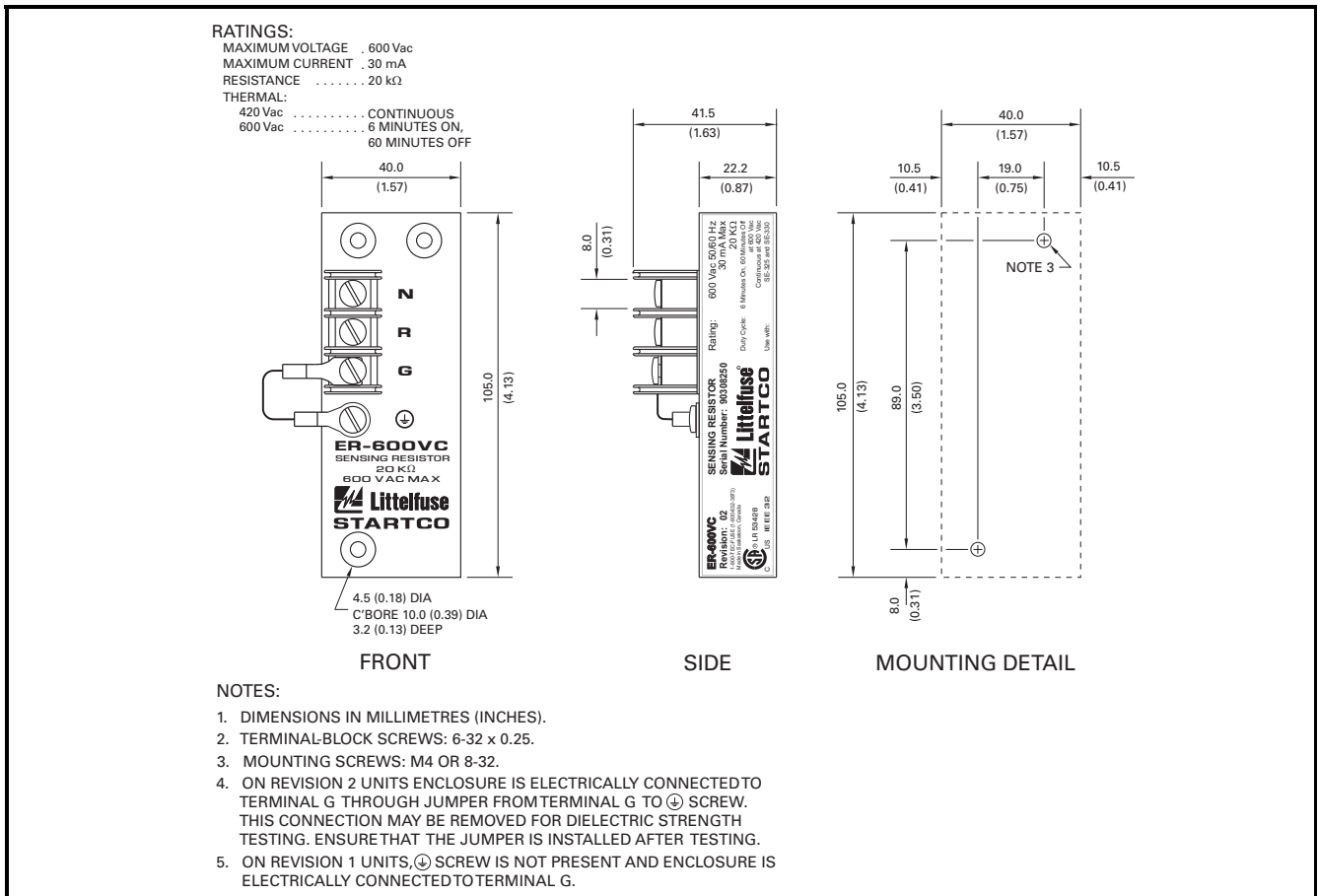
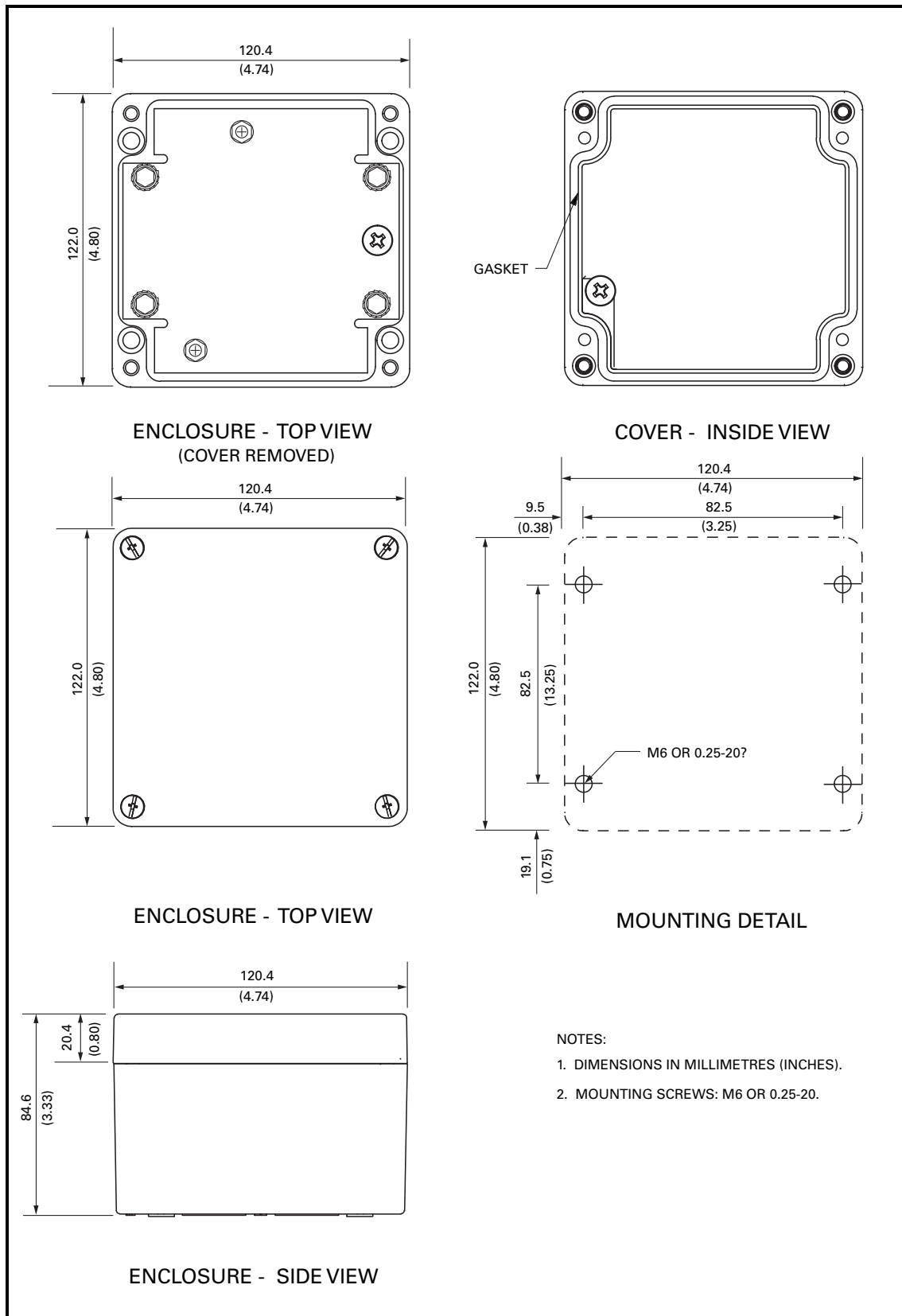

FIGURE 4. ER-600VC Sensing Resistor.



- NOTES:
1. DIMENSIONS IN MILLIMETRES (INCHES).
 2. MOUNTING SCREWS: M6 OR 0.25-20.

FIGURE 5. SE-MRE-600 Moisture-Resistant Enclosure.

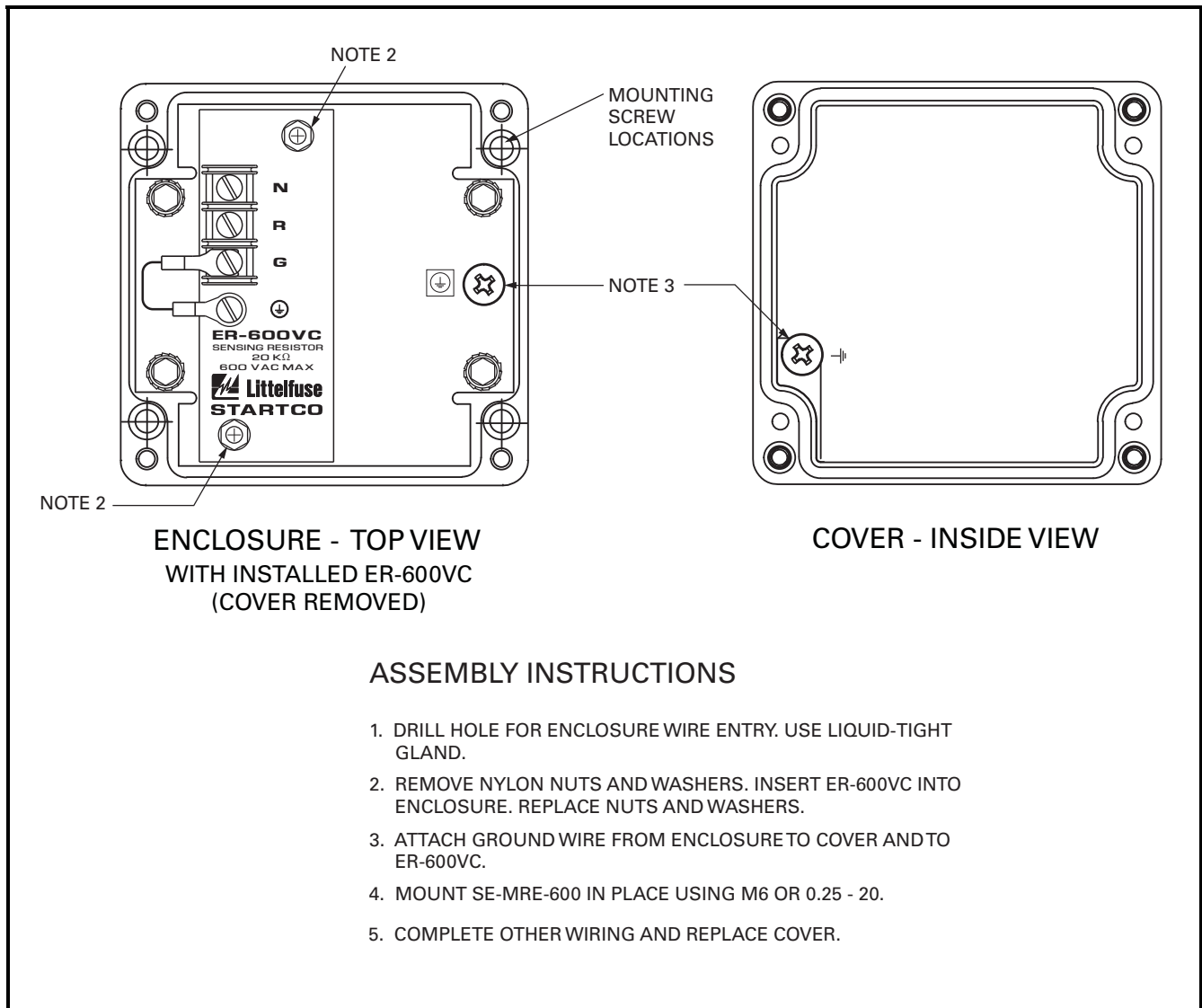
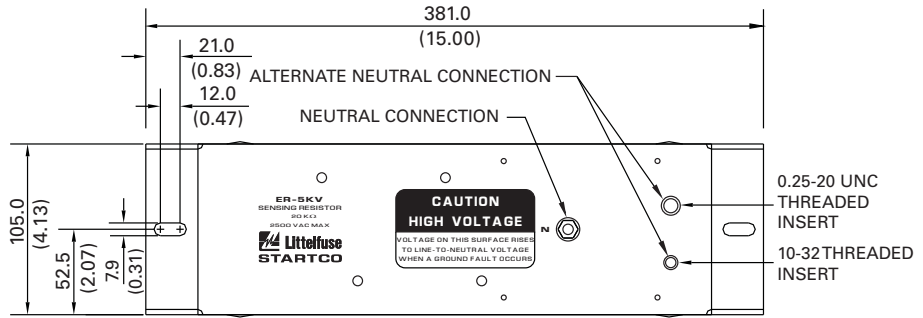
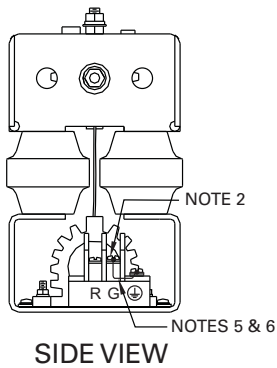

FIGURE 6. SE-MRE-600 with installed ER-600VC.

RATINGS:
 MAXIMUM VOLTAGE . 2,500 Vac
 MAXIMUM CURRENT. 125 mA
 RESISTANCE 20 kΩ
 THERMAL CONTINUOUS



TOP VIEW



FRONT VIEW

NOTES:

1. DIMENSIONS IN MILLIMETRES (INCHES).
2. TERMINAL-BLOCK SCREWS: 6-32 x 0.25.
3. MOUNTING SCREWS: M6 OR 0.25-20.
4. THIS DEVICE CAN DISSIPATE 300 WATTS. TO MINIMIZE SURFACE TEMPERATURES FOR SYSTEMS ALLOWED TO OPERATE CONTINUOUSLY WITH A GROUND FAULT, MOUNT VERTICALLY WITH R & G TERMINALS DOWN.
5. ON REVISION 2 UNITS BASE IS ELECTRICALLY CONNECTED TO TERMINAL G THROUGH JUMPER FROM TERMINAL G TO ⊕ SCREW. THIS CONNECTION MAY BE REMOVED FOR DIELECTRIC STRENGTH TESTING. ENSURE THAT THE JUMPER IS INSTALLED AFTER TESTING.
6. ON REV 0 & 1 UNITS ⊕ SCREW IS NOT PRESENT AND BASE IS ELECTRICALLY CONNECTED TO TERMINAL G.

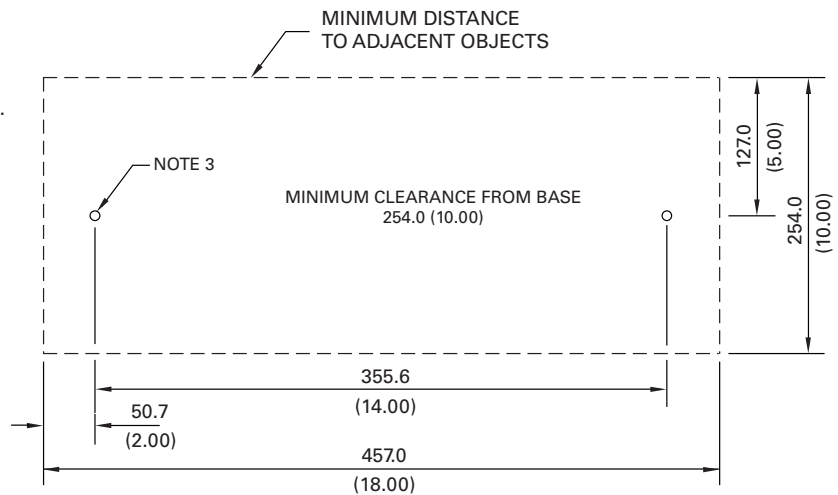

MOUNTING DETAIL

FIGURE 7. ER-5KV Sensing Resistor.

RATINGS:
 MAXIMUM VOLTAGE . . . 2,500 Vac
 MAXIMUM CURRENT. 125 mA
 RESISTANCE 20 kΩ
 THERMAL CONTINUOUS

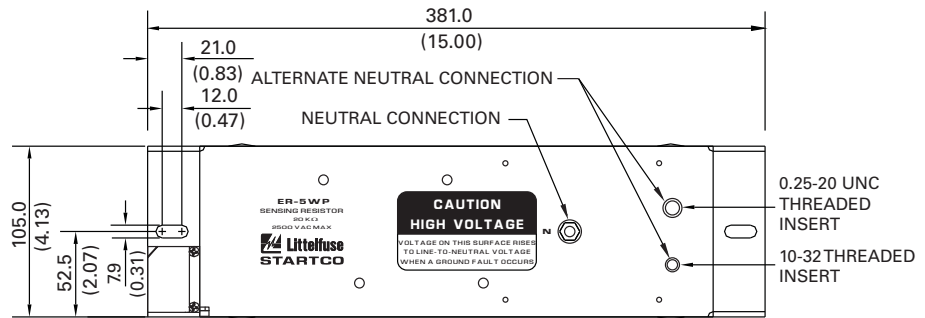

TOP VIEW

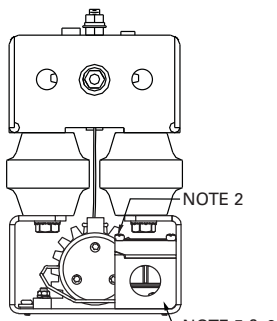

SIDE VIEW

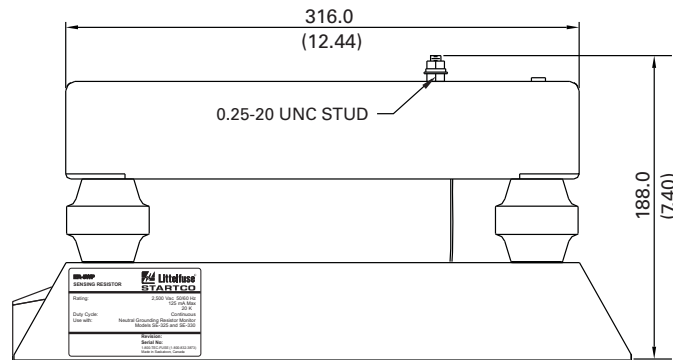

FRONT VIEW

NOTES:

1. DIMENSIONS IN MILLIMETRES (INCHES).
2. TERMINAL-BLOCK SCREWS: 6-32 x 0.25.
3. MOUNTING SCREWS: M6 OR 0.25-20.
4. THIS DEVICE CAN DISSIPATE 300 WATTS. TO MINIMIZE SURFACE TEMPERATURES FOR SYSTEMS ALLOWED TO OPERATE CONTINUOUSLY WITH A GROUND FAULT, MOUNT VERTICALLY WITH R & G TERMINALS DOWN.
5. BASE IS ELECTRICALLY CONNECTED TO TERMINAL G THROUGH JUMPER FROM TERMINAL G TO ⊕ SCREW. THIS CONNECTION MAY BE REMOVED FOR DIELECTRIC STRENGTH TESTING. ENSURE THAT THE JUMPER IS INSTALLED AFTER TESTING.
6. USE 1/2 NPT LIQUID-TIGHT GLAND FOR CABLE ENTRY. REMOVE GASKETED TERMINAL-BOX COVER FOR TERMINAL ACCESS.

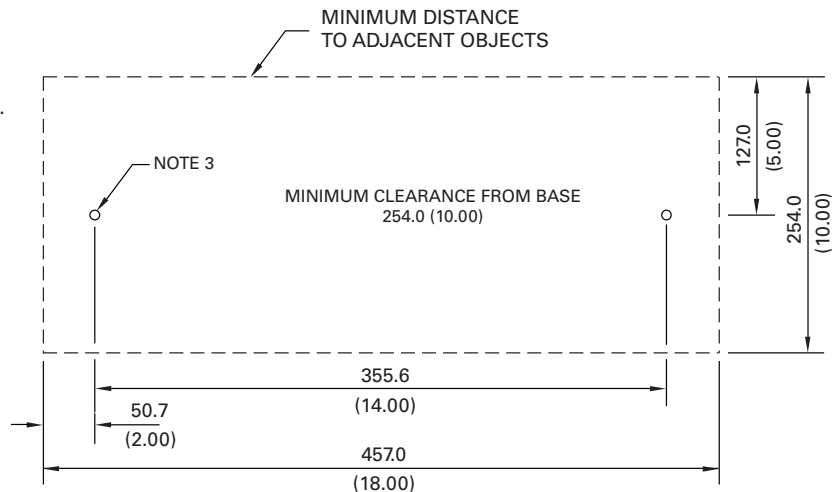

MOUNTING DETAIL

FIGURE 8. ER-5WP Sensing Resistor

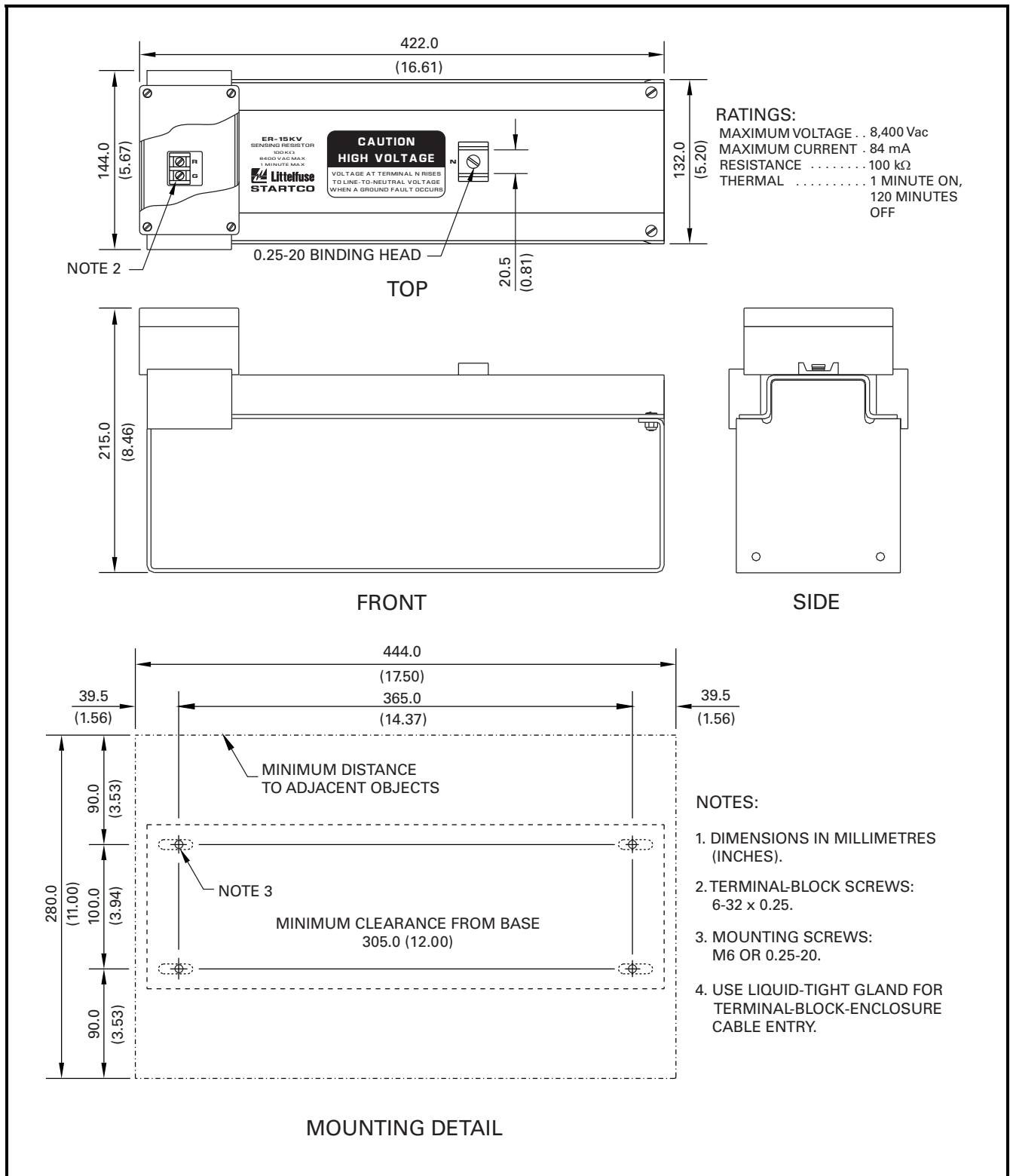

FIGURE 9. ER-15KV Sensing Resistor.

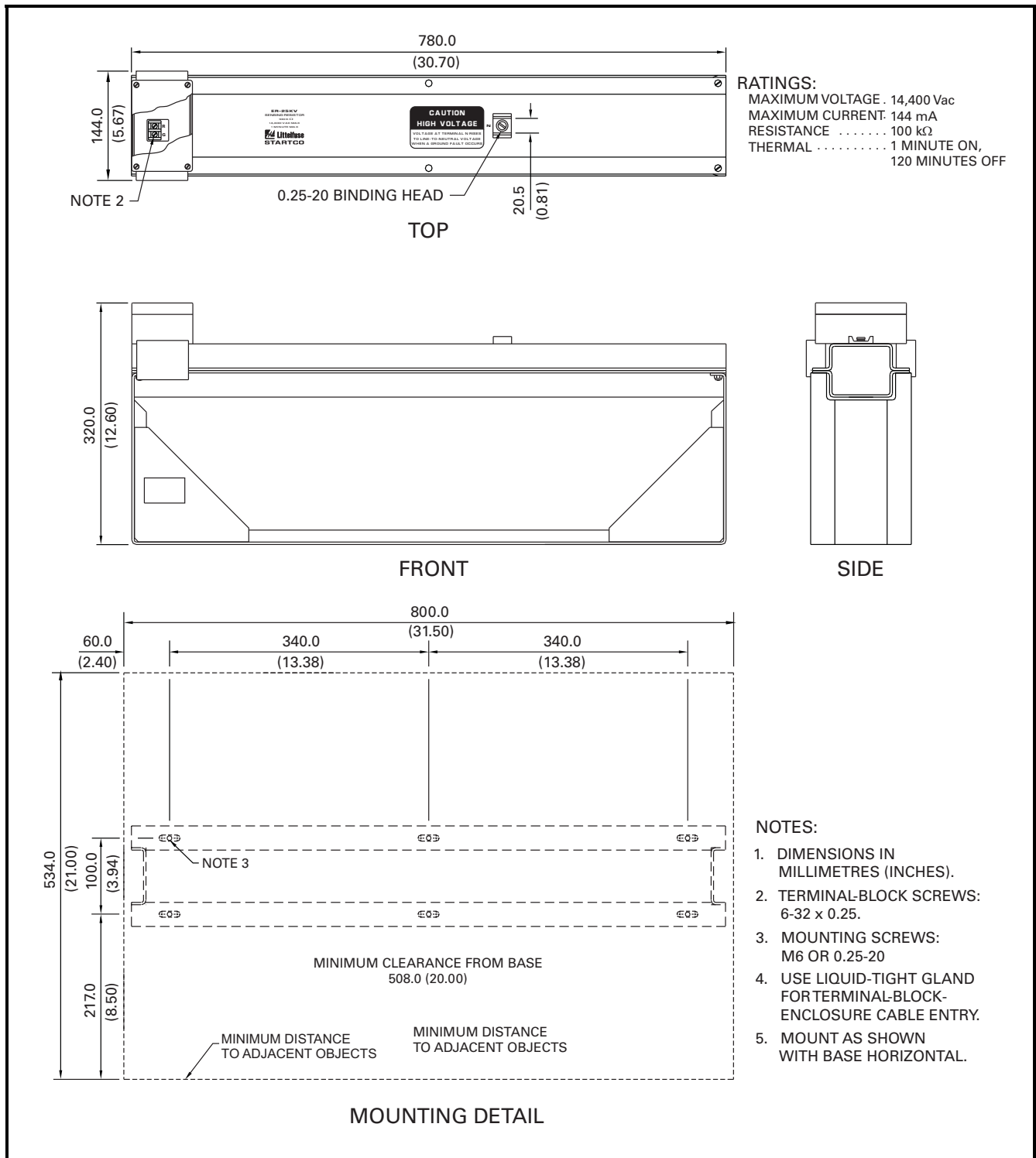

FIGURE 10. ER-25KV Sensing Resistor.

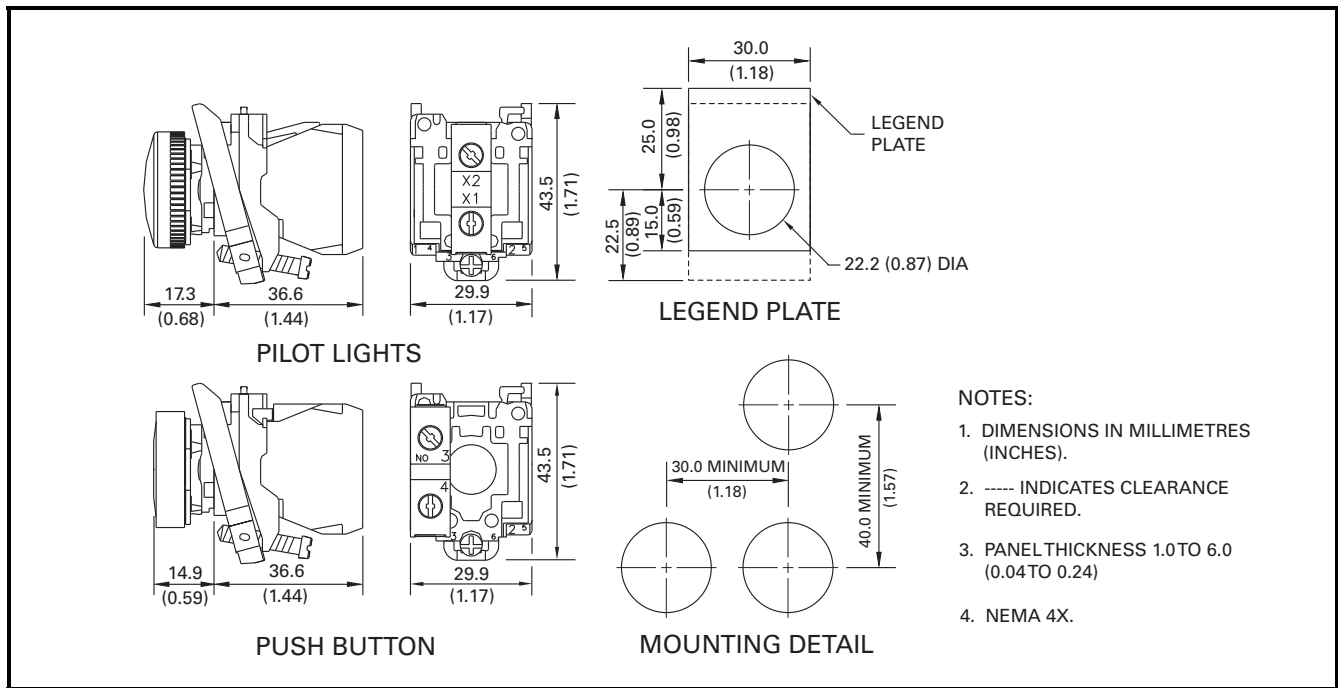

FIGURE 11. RK-302 Remote Indication and Reset

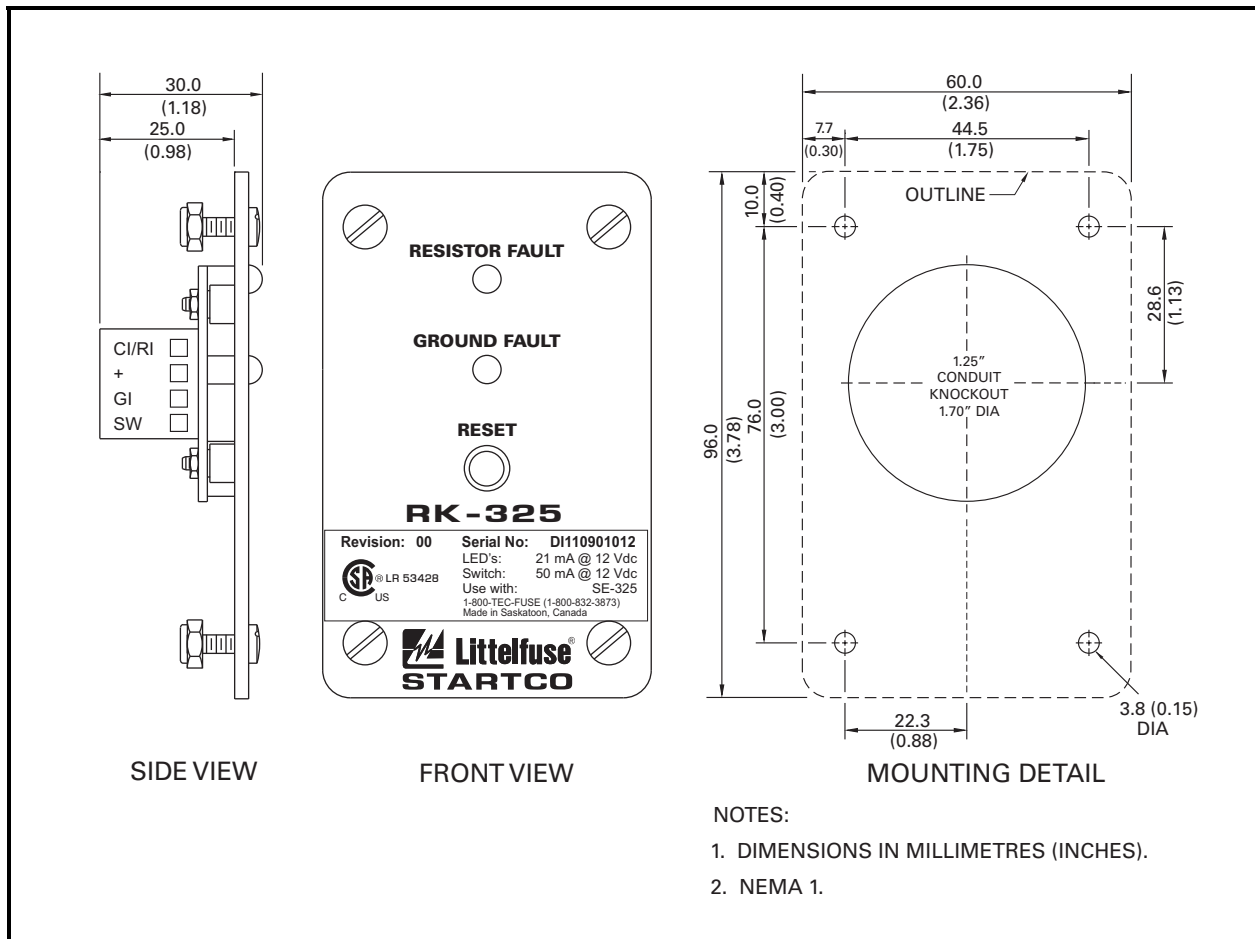

FIGURE 12. RK-325 Remote Indication-and-Reset Assembly.

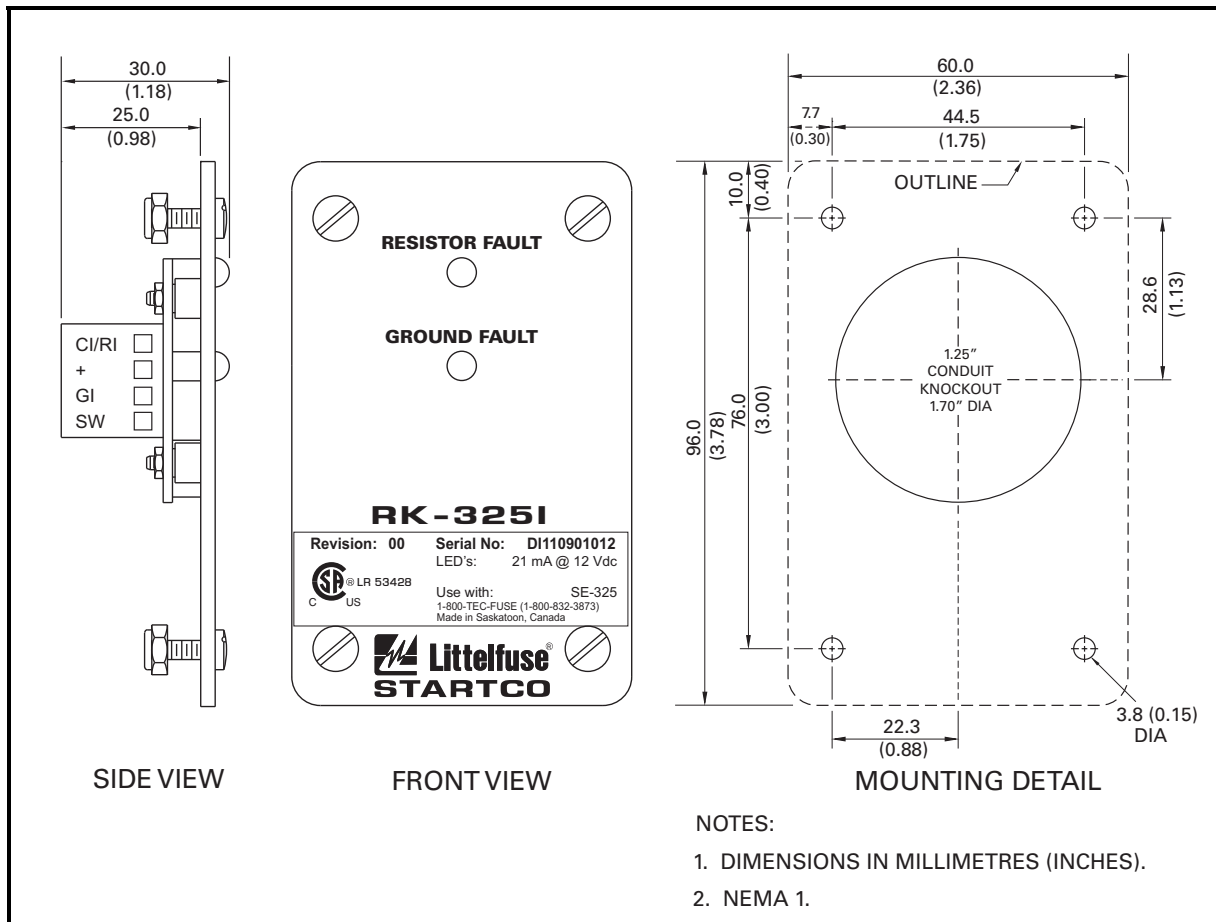

FIGURE 13. RK-325I Remote Indication Assembly.

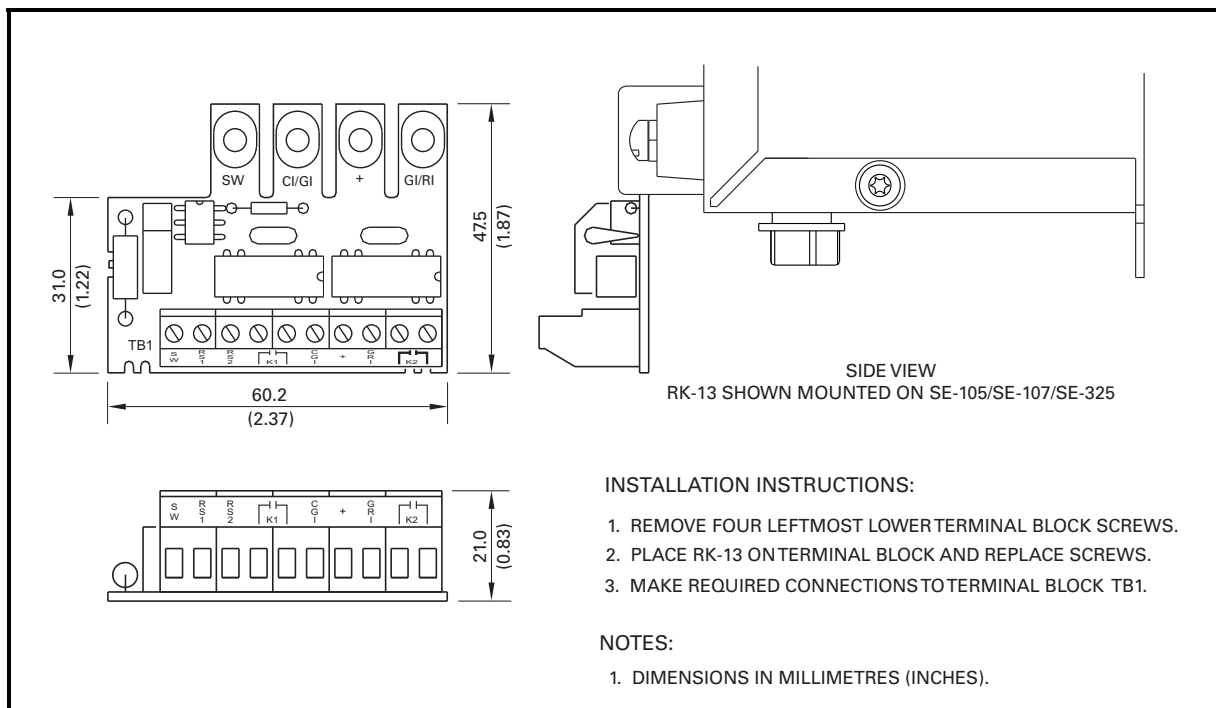

FIGURE 14. RK-13 Relay Interface Module.

3.4 ISOLATED-GROUND CONNECTION

The SE-325 is intended for use in installations where the NGR is connected to local ground. Some installations require the NGR to be isolated from local ground. See Technical Note RG-1 “NGR Monitoring with Isolated Ground Beds” at www.startco.ca.

3.5 OVERHEAD LINES

In overhead-line applications, atmospheric conditions can cause false resistor-fault trips. The “S” option or an SE-330 NGR Monitor is recommended for these applications.

3.6 REMOTE OPERATION

Terminals SW, GI, +, and RI are provided for remote LED indication and remote reset as shown in Fig. 1. Remote LED's are driven in series with the front-panel LED's.

Remove factory-installed jumpers from terminals GI, +, and RI, and connect a remote kit as shown in Fig. 1. Optional remote kits are shown in Figs. 8, 9, and 10. Standard LED indicator lamps are not compatible with the SE-325.

For general-purpose applications, use the RK-325 Remote Indication-and-Reset Assembly or the RK-325I Remote Indication Assembly. Connect terminals SW, GI, +, and RI to remote-kit terminals SW, GI, +, and CI/RI.

For 22-mm-component RK-302 applications, connect terminal X2 of the red ground-fault indicator to GI, terminal X2 of the red resistor-fault indicator to RI, and connect indicator X1 terminals to +. For remote reset, connect the normally open push-button switch across terminals + and SW.

If indication is required from a separate voltage source, or if separate ground-fault and resistor-fault contacts are required, use an RK-13 Relay Interface Module. The RK-13 mounts on the SE-325 lower terminal block and it is compatible with the RK-302, RK-325 and RK-325I. See Figs. 1 and 11. Contact K1 closes when the Ground-Fault LED is on and contact K2 closes when the Resistor-Fault LED is on.

3.7 GROUND-FAULT TESTING

Use CT-primary current injection to test the ground-fault circuit. Fig. 12 shows test circuits using the SE-400 Ground-Fault-Relay Test Unit and the SE-100T Ground-Fault-Relay Tester. The SE-400 has a programmable output of 0.5 to 9.9 A for a duration of 0.1 to 9.9 seconds. The SE-100T has LO and HI outputs for 5- and 15-A resistance-grounded systems.

A test-record form is provided in Section 7 of this manual. Record the test results and test dates on this form to meet the requirements of the National Electrical Code (NEC). Retain the form so that the test data can be made available to the authority having jurisdiction.

4. TECHNICAL SPECIFICATIONS

4.1 SE-325

Supply:

ac	10 VA, 120 or 240 Vac (+10, -50%), 50/60 Hz,
ac/dc	5 W, 120 Vdc (+40, -8%), or 5 VA, 120 Vac (+10, -29%), 47 to 440 Hz,

NOTE: Voltage between supply terminals (L1, L2) and ground terminal (G) must not exceed 300 Vac continuous or 1,250 Vac under transient conditions.

Dimensions:

Height.....	150 mm (5.9")
Width.....	109 mm (4.3")
Depth.....	100 mm (4.0")

Shipping Weight..... 1 kg (2.2 lb)

Environment:

Operating Temperature	-40 to 60°C
Storage Temperature	-55 to 80°C
Humidity	85% Non-Condensing

Ground-Fault Circuit:

CT Ratio.....	200:5
CT Input Burden.....	0.02 Ω
Trip Level ⁽¹⁾	0.5, 2.0, or 4.0 A
Frequency Response ⁽³⁾	25 to 110 Hz
Trip Time	0.1 to 2.0 s, 0.1 to 5.0 s with Option T
Thermal Withstand ⁽¹⁾	200 A Continuous, 2,500 A for 2 s
Trip-Level Accuracy	+10, -20%
CT Lead Resistance Limit ⁽²⁾	
0.5 A Trip Level.....	2 Ω
2 A Trip Level.....	5 Ω
4 A Trip Level.....	5 Ω
Trip-Time Accuracy	10%
Operating Mode.....	Latching, Non-latching with Option N

- (1) Currents referred to primary of CT200 for prospective ground-fault currents less than 4,000 A.
- (2) Typical maximum CT lead resistance to meet specified trip level accuracy.
- (3) Prior to hardware revision 11, standard unit freq. rep. was 25 to 400 Hz and option H was 25 to 110 Hz.

Resistor-Fault Circuit:
Neutral-To-Ground
Trip Voltage (V_N) 20 to 2,000 Vac Adjustable
NGR Trip Resistance, $V_N = 0$
ER-600VC or ER-5KV 2 k Ω
ER-15KV or ER-25KV 6 k Ω ,
50 k Ω with Option S
Neutral-To-Ground
DC-Voltage Rejection:
ER-600VC or ER-5KV .. 1.2 V
ER-15KV or ER-25KV .. 0.7 V, 4 V with Option S
Trip-Resistance Accuracy +5, -2% of Sensing
Resistor Resistance
Trip Time 5 \pm 0.5 s,
20 \pm 3 s with Option S
Operating Mode Latching,
Non-latching with
Option N

Output Relay:
CSA/UL Contact Rating 1 mA to 4 A Resistive,
240 Vac or 28 Vdc
Supplemental Contact Ratings:
Make/carry 0.2 s 10 A
Carry continuous 4 A
Break:
dc 20 W resistive,
10 W inductive
(L/R = 0.04 s)
ac 960 VA resistive,
700 VA inductive
(PF = 0.4)
Subject to maximums of 4 A and 240 V (ac or dc)
Contact Configuration N.O. (Form A)
Fuse Rating (F1) 4.0 A, 250 Vac,
Time Delay
Fuse Part Number Bussman MSL-4 or
Littelfuse 313.004
Operating Mode UV (Fail-Safe) or
SH (Non-Fail-Safe)

Remote Indication:
+ 12 Vdc
GI/RI Current Sink,
560 Ω Internal

Optional RK-13 Module:
Contact Ratings 100 mA, 120 Vac
Contact Configuration N.O. (Form A)
Reset Input 24 to 120 V (ac or dc),
Isolated

PWB Conformal Coating MIL-1-46058 qualified,
UL QMJU2 recognized

4.2 SENSING RESISTORS

ER-600VC:
Maximum Voltage 600 Vac
Maximum Current 30 mA
Resistance 20 k Ω
Thermal:
420 Vac Continuous
600 Vac 6 minutes on,
60 minutes off
Shipping Weight 300 g (0.7 lb)

ER-5KV:
Maximum Voltage 2,500 Vac
Maximum Current 125 mA
Resistance 20 k Ω
Thermal Continuous
Shipping Weight 5.0 kg (11 lb)

ER-15KV:
Maximum Voltage 8,400 Vac
Maximum Current 84 mA
Resistance 100 k Ω
Thermal 1 minute on,
120 minutes off
Shipping Weight 5.0 kg (11 lb)

ER-25KV:
Maximum Voltage 14,400 Vac
Maximum Current 144 mA
Resistance 100 k Ω
Thermal 1 minute on,
120 minutes off
Shipping Weight 20 kg (44 lb)

4.3 CURRENT TRANSFORMER

CT200:
Current Ratio 200:5 A
Insulation 600-V Class
Window Diameter 56 mm (2.2")
Shipping Weight 1 kg (2.2 lb)
Certification CSA, Canada and USA



UL Listed



Australia



Commonwealth of Pennsylvania
SE-325 BOTE 1767-99
SE-325P BOTE 1797-00\

5. ORDERING INFORMATION

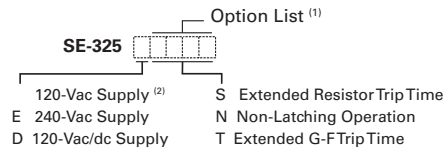

(1) List options required in order shown above.
(2) Standard, leave blank.

SE-325P Approved by
The Commonwealth of Pennsylvania
for 4,800-Ω NGR.
Requires 20-kΩ sensing resistor.

Sensing Resistors:

ER-600VC.....	For system voltages up to 1 kVac
SE-MRE-600	Optional ER-600VC moisture- resistant enclosure
ER-5KV	For system voltages up to 5 kVac
ER-5WP	For system voltages up to 5 kVac
ER-15KV	For system voltages up to 15 kVac
ER-25KV	For system voltages up to 25 kVac

Ground-Fault CT:

CT200.....	56 mm (2.2") Window
------------	---------------------

Remote Indication and Reset:

RK-302.....	Includes two LED pilot lights, a reset push button, and legend plates
RK-325	Indication-and-Reset Assembly
RK-325I	Indication Assembly
RK-13	Relay Interface Module

6. WARRANTY

The SE-325 Neutral-Grounding-Resistor Monitor is warranted to be free from defects in material and workmanship for a period of five years from the date of purchase.

Littelfuse Startco will (at Littelfuse Startco's option) repair, replace, or refund the original purchase price of an SE-325 that is determined by Littelfuse Startco to be defective if it is returned to the Startco factory, freight prepaid, within the warranty period. This warranty does not apply to repairs required as a result of misuse, negligence, an accident, improper installation, tampering, or insufficient care. Littelfuse Startco does not warrant products repaired or modified by non-Littelfuse Startco personnel.

Littelfuse Startco is not liable for contingent or consequential damages; for expenses sustained as a result of incorrect application, incorrect adjustment, or a malfunction; or for expenses resulting from the use of, or inability to use, the product.

7.2 RESISTOR-FAULT TESTS

Perform tests with system de-energized and supply voltage applied to the SE-325.

7.2.1 OPEN TEST

Test Equipment: 20-k Ω and 100-k Ω , 1/4-watt, 1% resistors (included with SE-325).

Procedure:

- Remove connections to SE-325 R and G terminals.
- Connect the 20-k Ω resistor to R and G terminals.
- Set the RES switch to 20K.
- Press RESET.
- The RESISTOR-FAULT LED should be off.
- Remove the test resistor and wait 5 seconds (20 seconds with Option S).
PASS: The SE-325 should trip on RESISTOR FAULT.
- Connect the 100-k Ω resistor to R and G terminals.
- Set the RES switch to 100K.
- Press RESET.
- The RESISTOR-FAULT LED should be off.
- Remove the test resistor and wait 5 seconds (20 seconds with Option S).
PASS: The SE-325 should trip on RESISTOR FAULT.

To test the connected wiring, sensing resistor, and NGR:

- Reconnect SE-325 R and G connections.
- Set the RES switch to match sensing resistor.
- Press RESET.
PASS: The RESISTOR FAULT LED should be off.

7.2.2 VOLTAGE TEST

Test Equipment: 0 to 120 Vac voltage source and multimeter.

NOTE: Also use an isolation transformer if the test-voltage source does not provide dc continuity for the SE-325 resistance-measurement circuit.

NOTE: Applying the test voltage to the R and G terminals will damage the SE-325 and the ER sensing resistor. The RES TRIP LEVEL is the trip voltage at terminal N, not terminal R.

Procedure:

- Check the ER sensing resistor connection to the SE-325.
- Disconnect the wire from sensing resistor terminal N. A resistor-fault trip will occur.
- Set the voltage source to 0 V.
- Connect the voltage source between sensing resistor N and G terminals.
- Set the RES TRIP LEVEL (VAC) to 20.
- Press RESET.
- The RESISTOR-FAULT LED should be off.
- Increase the test voltage to 25 Vac for 20-k Ω sensors or

120 Vac for 100-k Ω sensors and wait 5 seconds (20 seconds with Option S).

PASS: The SE-325 should trip on RESISTOR FAULT.

7.3 SENSING-RESISTOR TEST

Test Equipment: Multimeter.

Procedure:

- Disconnect the sensing resistor.
- Measure the resistance between sensing-resistor terminals R and N.
PASS: Resistance should be between 19.6 and 20.4 k Ω for 20-k Ω sensing resistors. Resistance should be between 98 and 102 k Ω for 100-k Ω sensing resistors.
- Measure the resistance between sensing-resistor terminals R and G in both directions.
PASS: Resistance should be greater than 10 M Ω in both directions.