

# SE-105 MANUAL

## GROUND-FAULT GROUND-CHECK MONITOR

OCTOBER 25, 2011

REVISION 11

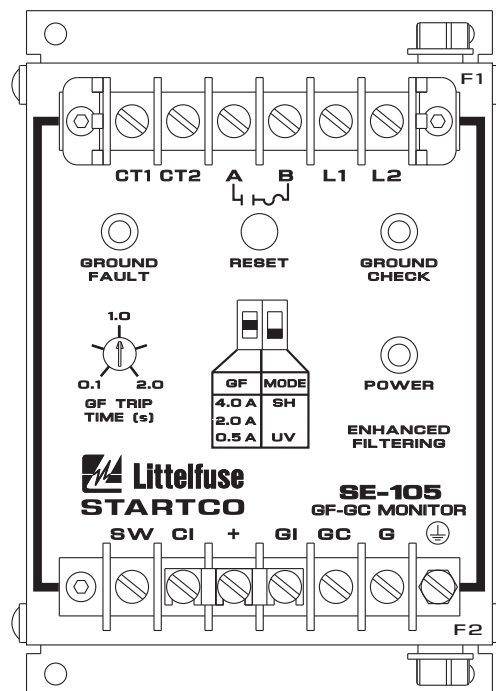

Copyright © 2011 by Littelfuse Startco

All rights reserved.

## TABLE OF CONTENTS

	PAGE
Table of Contents .....	i
List of Figures .....	i
List of Tables.....	i
<b>1. General .....</b>	<b>1</b>
<b>2. Operation.....</b>	<b>1</b>
2.1 Settings .....	1
2.1.1 GF Trip Time .....	1
2.1.2 GF .....	1
2.1.3 Mode.....	1
2.2 Indication and Reset .....	1
2.3 Fusing.....	1
<b>3. Installation.....</b>	<b>1</b>
3.1 SE-105.....	1
3.2 Ground-Fault CT .....	3
3.3 Ground-Check Termination.....	4
3.4 Remote Operation.....	5
3.5 Parallel-Path Isolation.....	5
3.6 Ground-Fault Testing .....	5
<b>4. Compatibility .....</b>	<b>5</b>
<b>5. Technical Specifications .....</b>	<b>11</b>
<b>6. Ordering Information .....</b>	<b>12</b>
<b>7. Warranty .....</b>	<b>12</b>
<b>8. Ground-Fault Performance Test.....</b>	<b>13</b>

## LIST OF FIGURES

FIGURE	PAGE
1 Typical Application .....	2
2 SE-105 Outline and Mounting Details.....	3
3 Current Transformers.....	4
4 Zener-Diode Termination Devices.....	5
5 SE-TA6 Termination Assembly.....	6
6 SE-TA6ASF-WL Small-Format Termination Assembly with Wire Leads .....	6
7 RK-102 Remote Indication and Reset .....	7
8 RK-105 Remote Indication-and-Reset Assembly ....	7
9 RK-105I Remote Indication Assembly .....	8
10 RK-13 Relay Interface Module.....	8
11 PPI-600V Parallel-Path Isolator.....	9
12 PPI-600V Typical Installation .....	10
13 Ground-Fault-Test Circuits .....	13

## LIST OF TABLES

TABLE	PAGE
1 Terminal Designations .....	4
2 Ground-Fault-Test Record .....	14

## DISCLAIMER

Specifications are subject to change without notice. Littelfuse Startco is not liable for contingent or consequential damages, or for expenses sustained as a result of incorrect application, incorrect adjustment, or a malfunction.

## 1. GENERAL

The SE-105 is a combination ground-fault and ground-check monitor for resistance-grounded systems in non-hazardous applications. The ground-fault circuit is latching and the ground-check circuit is typically non-latching. One output contact is provided for contactor control, or for shunt or undervoltage operation in a breaker trip circuit.

Ground-fault current is sensed by a CT200-series window-type current transformer. A trip level of 0.5, 2.0, or 4.0 A is switch selectable for use with a 5-, 15-, or 25-A grounding resistor. Enhanced filtering eliminates false ground-fault trips from adjustable-speed-drive harmonic distortion. Trip time is adjustable from 0.1 to 2.0 seconds.

The fail-safe ground-check circuit is validated by an end-of-line termination with a 5.6-volt Zener characteristic. The Zener characteristic clamps induced voltage and allows induced current to flow in the ground-check loop. Consequently, induced-ac-withstand capability, noise immunity, and open/short detection are independent of current in the phase conductors. Enhanced filtering prevents false ground-check validation due to an active chopper condition. See [www.startco.ca](http://www.startco.ca) for Technical Note GC-1.

**CAUTION:** The SE-105 is not a lock-out device. Follow lock-out procedures for maintenance.

## 2. OPERATION

### 2.1 SETTINGS

#### 2.1.1 GF TRIP TIME

Ground-fault trip time is adjustable from 0.1 to 2.0 seconds. Time-coordinated ground-fault protection requires this setting to be longer than the trip time of downstream ground-fault devices.

#### 2.1.2 GF

The ground-fault-circuit trip level is 0.5, 2.0, or 4.0 A when current is sensed with a CT200-series current transformer. Since the ground-fault-circuit trip level should not be greater than 20% of the grounding resistor let-through current, these levels are appropriate for use with 5-, 15-, or 25-A grounding resistors. For other applications, the trip level of the ground-fault circuit is 0.25, 1.0, or 2.0% of the primary rating of the 5-A-secondary current transformer.

#### 2.1.3 MODE

In the shunt-trip mode (SH), the output relay energizes and its contact closes if the ground-check loop becomes invalid or if a ground-fault trip occurs. The shunt-trip mode is not fail-safe and is not recommended because:

- Shunt-trip devices do not operate if supply voltage fails.
- Shunt-trip ground-check circuits allow open cable couplers to be energized for a short interval after supply voltage is applied.

In the undervoltage mode (UV), the output relay is energized and its contact is closed when the ground-check loop is valid and the ground-fault circuit is not tripped. The undervoltage mode is referred to as fail-safe and is recommended because:

- Undervoltage devices release if supply voltage fails.
- Undervoltage ground-check circuits do not allow cable couplers to be energized until the ground-check loop is verified.

For fail-safe-only applications, use an SE-107 GF-GC Monitor.

## 2.2 INDICATION AND RESET

The blue POWER LED indicates that the internal power supply is on. The red GROUND FAULT LED indicates a ground-fault trip and the green GROUND CHECK LED indicates a valid ground-check loop. When a ground-fault trip occurs, the SE-105 remains latched until the reset switch is pressed or the supply voltage is cycled. The ground-check circuit is non-latching and does not require a reset. Terminals are provided for remote indication and reset as shown in Fig. 1.

For latching ground-check Option L, the GROUND CHECK LED is red and it indicates a latched ground-check trip.

## 2.3 FUSING

The output contact is protected by fuse F1 (4.0 A, time delay). The ground-check circuit is protected by fuse F2 (0.5 A, time delay).

## 3. INSTALLATION

### 3.1 SE-105

SE-105 outline and mounting details are shown in Fig. 2. Typical connections are shown in Fig. 1. Connect supply voltage to L1 and L2. For a 120-Vac supply, connect supply neutral to L2. For direct-current supply Option D, connect supply negative to L2. Connect chassis-bonding terminal  $\oplus$  to ground.

Connect contact terminals A and B as required.

Face-plate LED's are driven in series with remote-indication LED's. When a remote kit is not used, terminals CI, +, and GI must be connected for the face-plate LED's to operate. These jumpers are installed at the factory.

Connect terminal GC to the outgoing ground-check conductor and connect terminal G to ground. To meet electrical code requirements, do not jumper chassis-bonding terminal  $\oplus$  to terminal G.

Install the upper terminal-block cover to prevent inadvertent contact with line terminals.



**3.2 GROUND-FAULT CT**

Outline and mounting details for CT200 and CT200L current transformers are shown in Fig. 3. Pass the phase conductors through the CT window as shown in Fig. 1.

Do not pass the ground or ground-check conductors through the CT. In applications that require shields or drain wires to pass through the CT, return them through the CT before connecting them to ground.

Connect the secondary of the ground-fault CT to SE-105 terminals CT1 and CT2. The CT connection to the SE-105 is not polarity sensitive. Ground one side of the CT secondary.

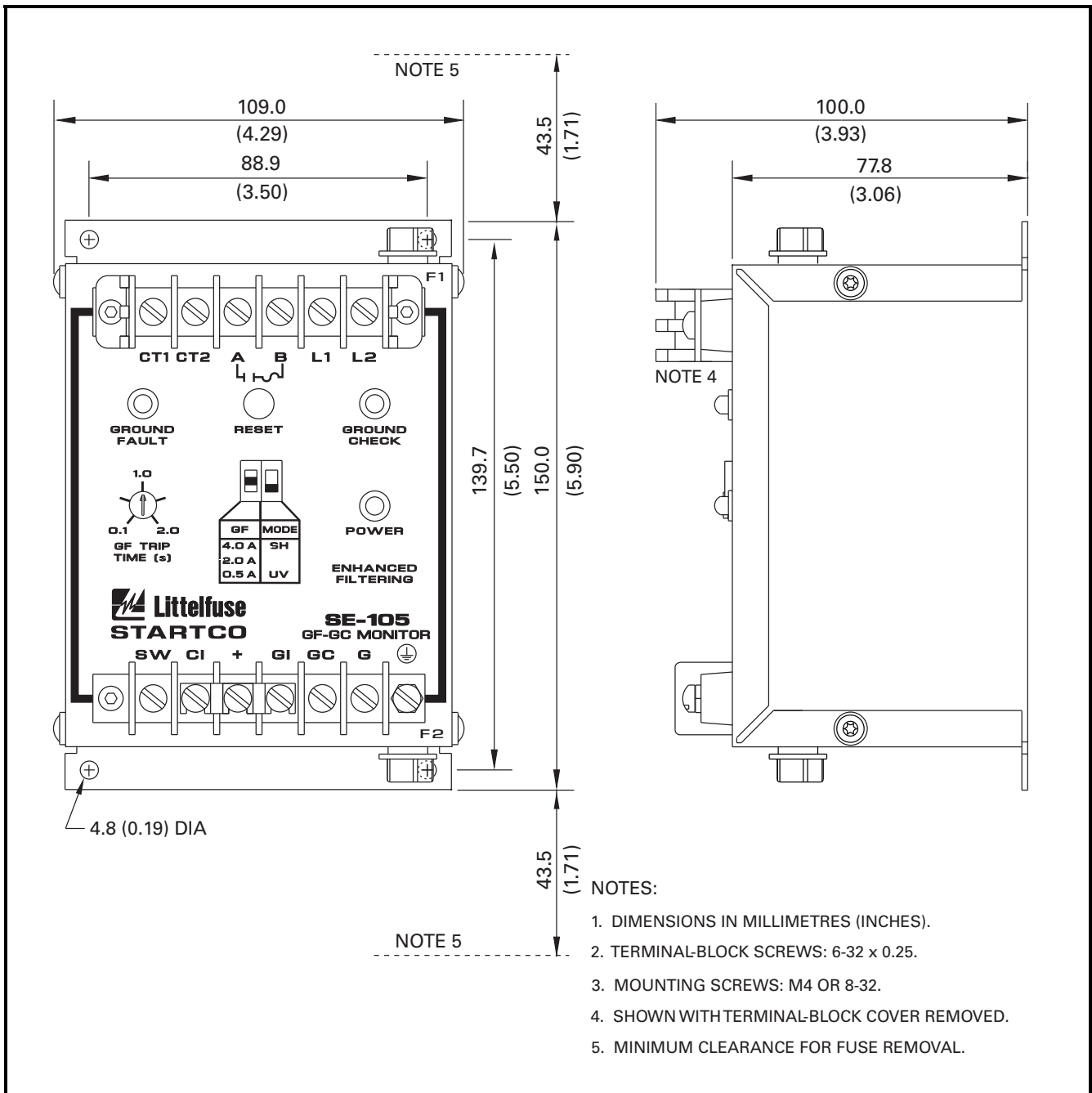

FIGURE 2. SE-105 Outline and Mounting Details.

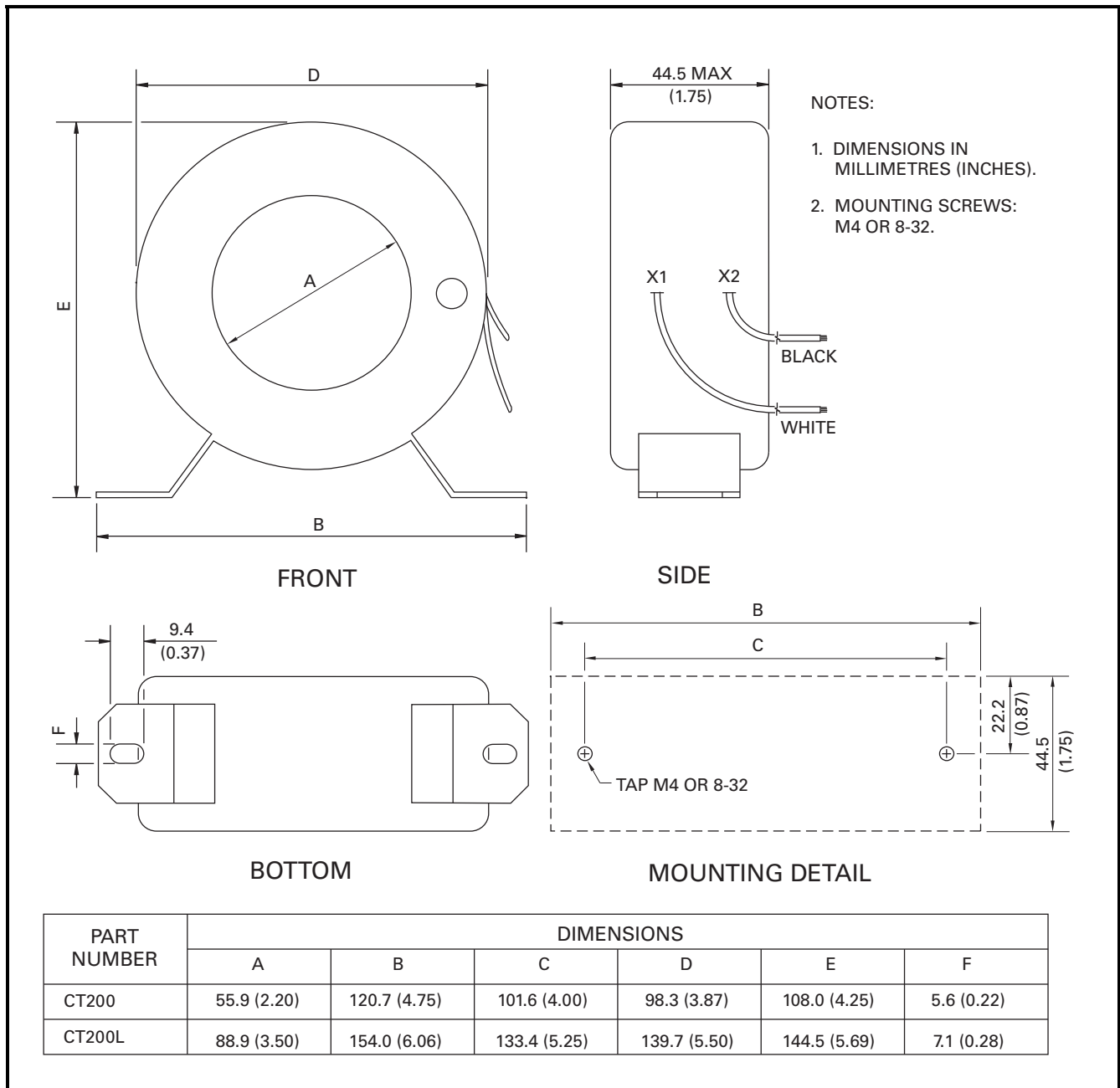

FIGURE 3. Current Transformers.

**3.3 GROUND-CHECK TERMINATION**

Install the ground-check termination at the load to complete the ground-check loop as shown in Fig. 1. Termination outlines and mounting details are shown in Figs. 4, 5 and 6. Use only a Littelfuse Startco termination device; others may not meet performance requirements. Connect terminal G of the termination to the equipment frame so that the ground-conductor-to-equipment-frame connection is included in the monitored ground-check

loop. Connect terminal GC of the termination to the incoming ground-check conductor.

If ground-check interlocks are used, low-level (bifurcated, precious-metal, or sealed-reed) contacts are recommended.

If used as a ground-fault monitor only, install the termination at the SE-105.

**3.4 REMOTE OPERATION**

Terminals SW, CI, +, and GI are provided for remote LED indication and remote reset as shown in Fig. 1. Remote LED's are driven in series with the front-panel LED's.

Remove factory-installed jumpers from terminals CI, +, and GI, and connect a remote kit as shown in Fig. 1. Optional remote kits are shown in Figs. 7, 8, and 9. Standard LED indicator lamps are not compatible with the SE-105.

For general-purpose applications, use the RK-105 Remote Indication-and-Reset Assembly or the RK-105I Remote Indication Assembly. Connect terminals SW, CI, +, and GI to remote-kit terminals SW, CI/RI, +, and GI.

For 22-mm-component RK-102 applications, connect terminal X2 of the green ground-check indicator to CI, terminal X2 of the red ground-fault indicator to GI, and connect indicator X1 terminals to +. For remote reset, connect the normally open push-button switch across terminals + and SW.

If indication is required from a separate voltage source, or if separate ground-fault and ground-check contacts are required, use an RK-13 Relay Interface Module. The RK-13 mounts on the SE-105 lower terminal block and is compatible with the RK-102, RK-105 and RK-105I. See Figs. 1 and 10. Contact K1 closes when the GC LED is on and contact K2 closes when the GF LED is on.

**3.5 PARALLEL-PATH ISOLATION**

A PPI-600V can be used for parallel-path rejection. A PPI-600V will also eliminate intermachine arcing and prevent stray ac and dc currents from flowing in the monitored ground wire. See Figs. 11 and 12. See Technical Note GC-10 "Parallel Path Isolator" at [www.startco.ca](http://www.startco.ca), or contact Littelfuse Startco for application details.

**3.6 GROUND-FAULT TESTING**

Use CT-primary current injection to test the ground-fault circuit. Fig. 13 shows test circuits using the SE-400 Ground-Fault-Relay Test Unit and the SE-100T Ground-Fault-Relay Tester. The SE-400 has a programmable output of 0.5 to 9.9 A for a duration of 0.1 to 9.9 seconds. The SE-100T has LO and HI outputs for 5- and 15-A resistance-grounded systems.

A test-record form is provided in Section 8 of this manual. Record the test results and test dates on this form to meet the requirements of the National Electrical Code (NEC). Retain the form so that the test data can be made available to the authority having jurisdiction.

**4. COMPATIBILITY**

The SE-105 is a direct replacement for the SEL-100, SEL-100TD, SE-101, SE-101S, SE-102, SE-102S, SE-102M, SE-103, and SE-103S. Terminal designations have been changed as shown in Table 1.

Terminals CT1 and CT2 are transformer isolated so that the CT secondary can be grounded. Units with old designations do not allow the secondary of the ground-fault CT to be grounded when the ground-check circuit is used.

TABLE 1. TERMINAL DESIGNATIONS

OLD DESIGNATION	SE-105 DESIGNATION
CT	CT1
CT	CT2
(RELAY)	A
(RELAY)	B
L	L1
N	L2
SW	SW
PL	CI
+	+
GL	GI
P	GC
G	G

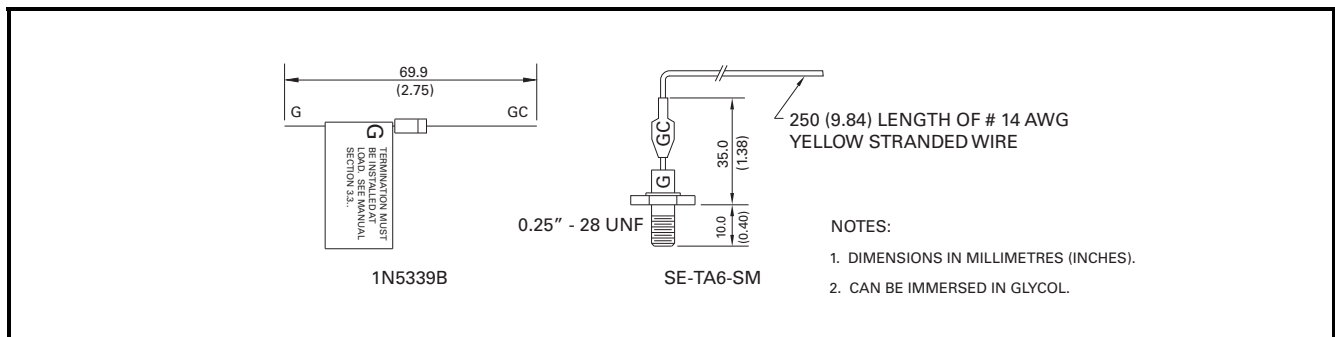

FIGURE 4. Zener-Diode Termination Devices.

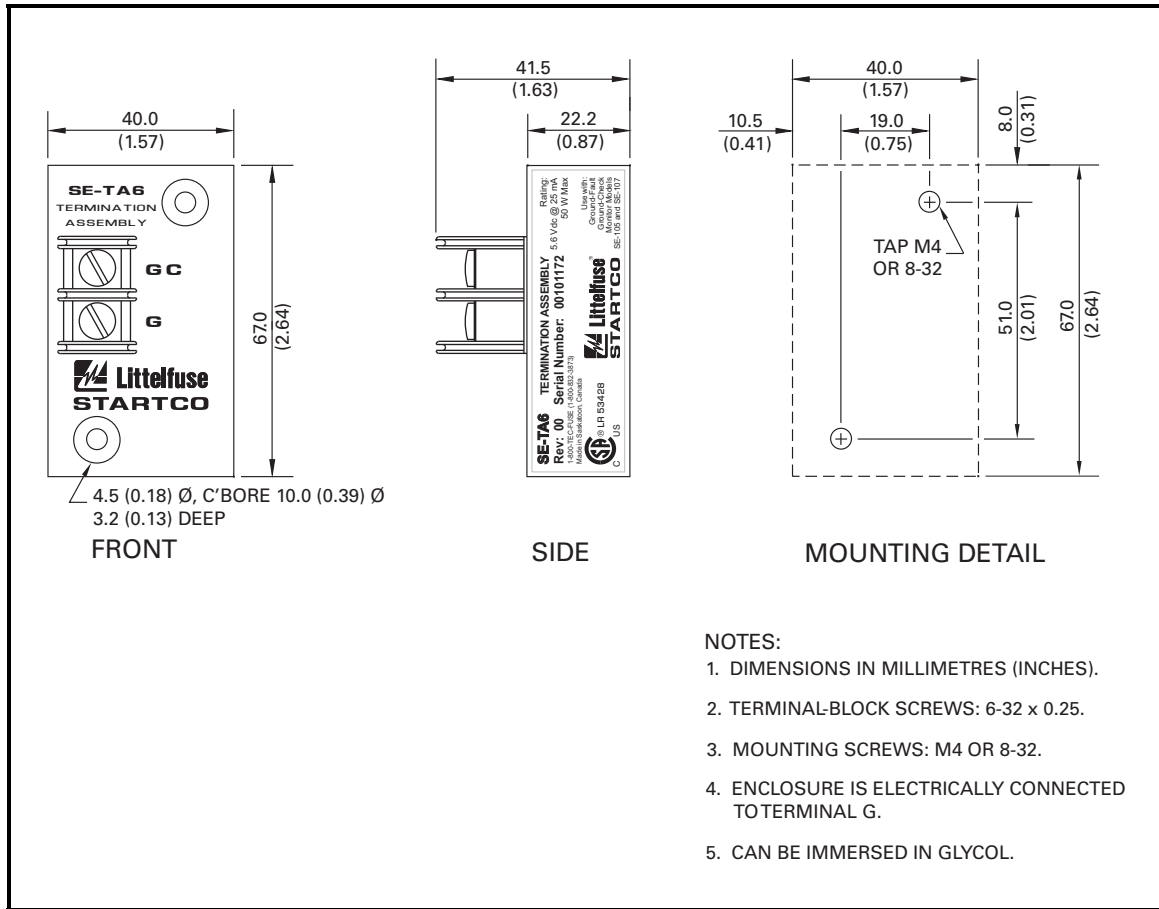

FIGURE 5. SE-TA6 Termination Assembly.

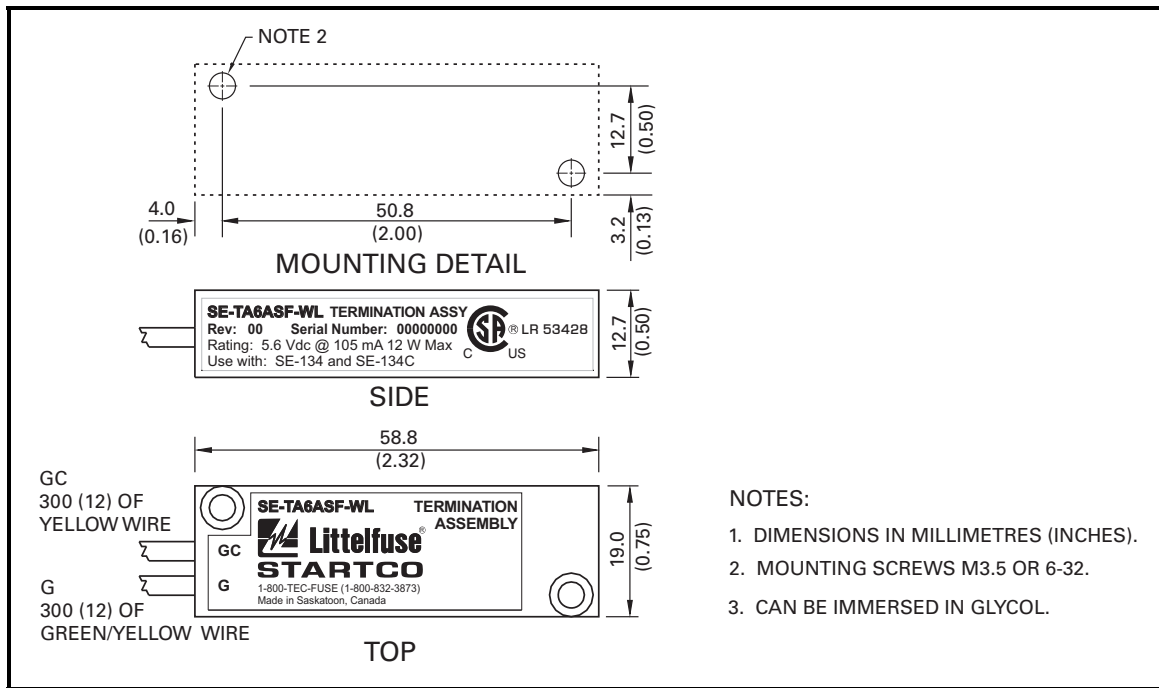

FIGURE 6. SE-TA6SF-WL Small-Format Termination Assembly with Wire Leads.

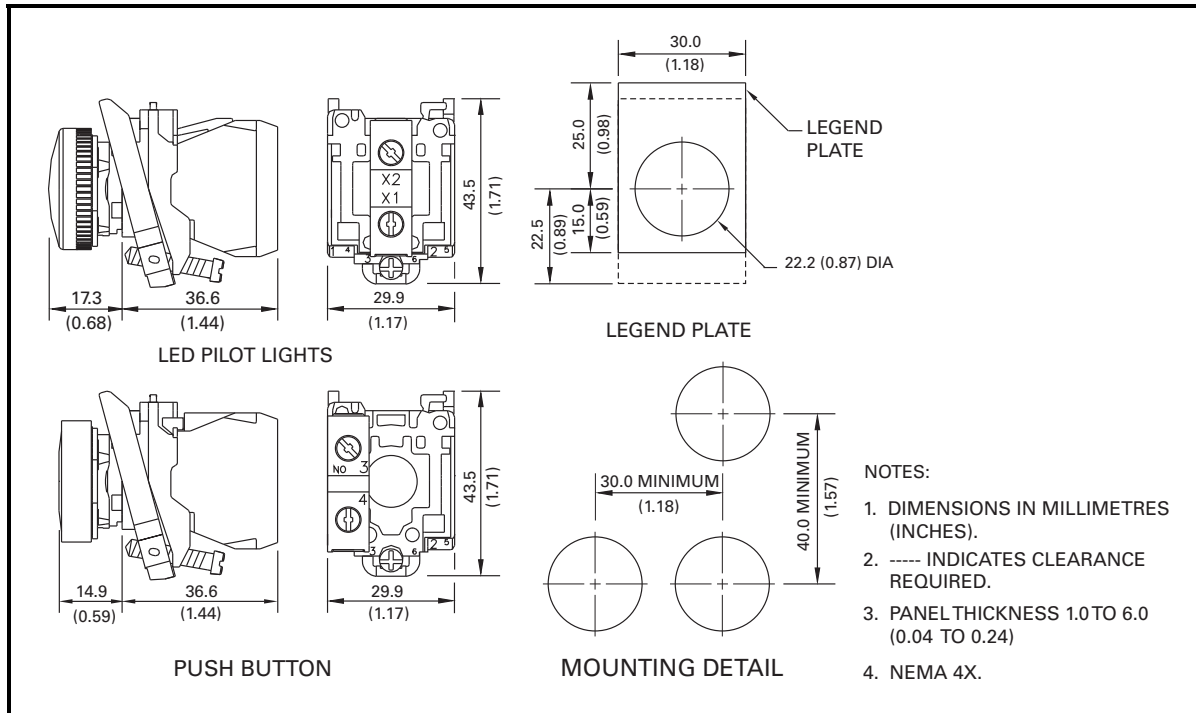

FIGURE 7. RK-102 Remote Indication and Reset.

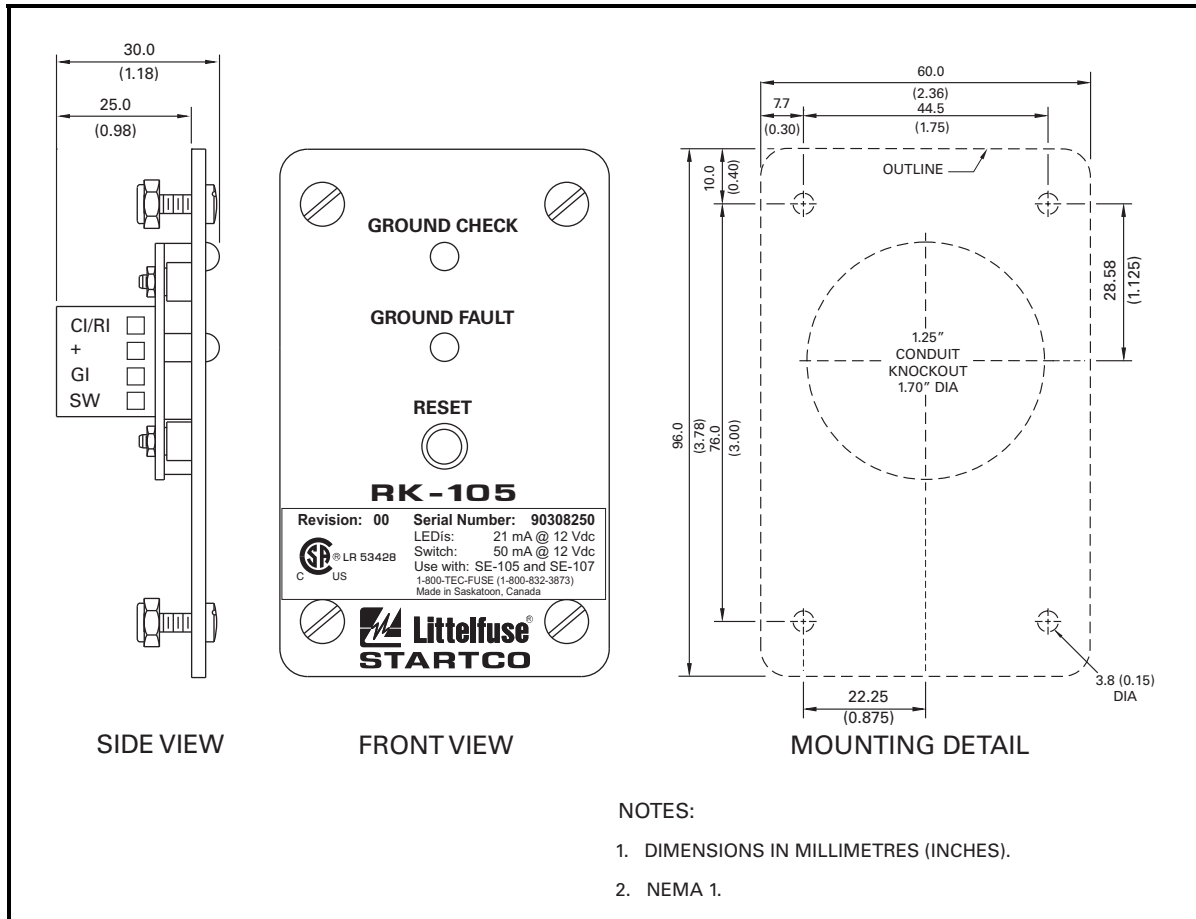

FIGURE 8. RK-105 Remote Indication-and-Reset Assembly.

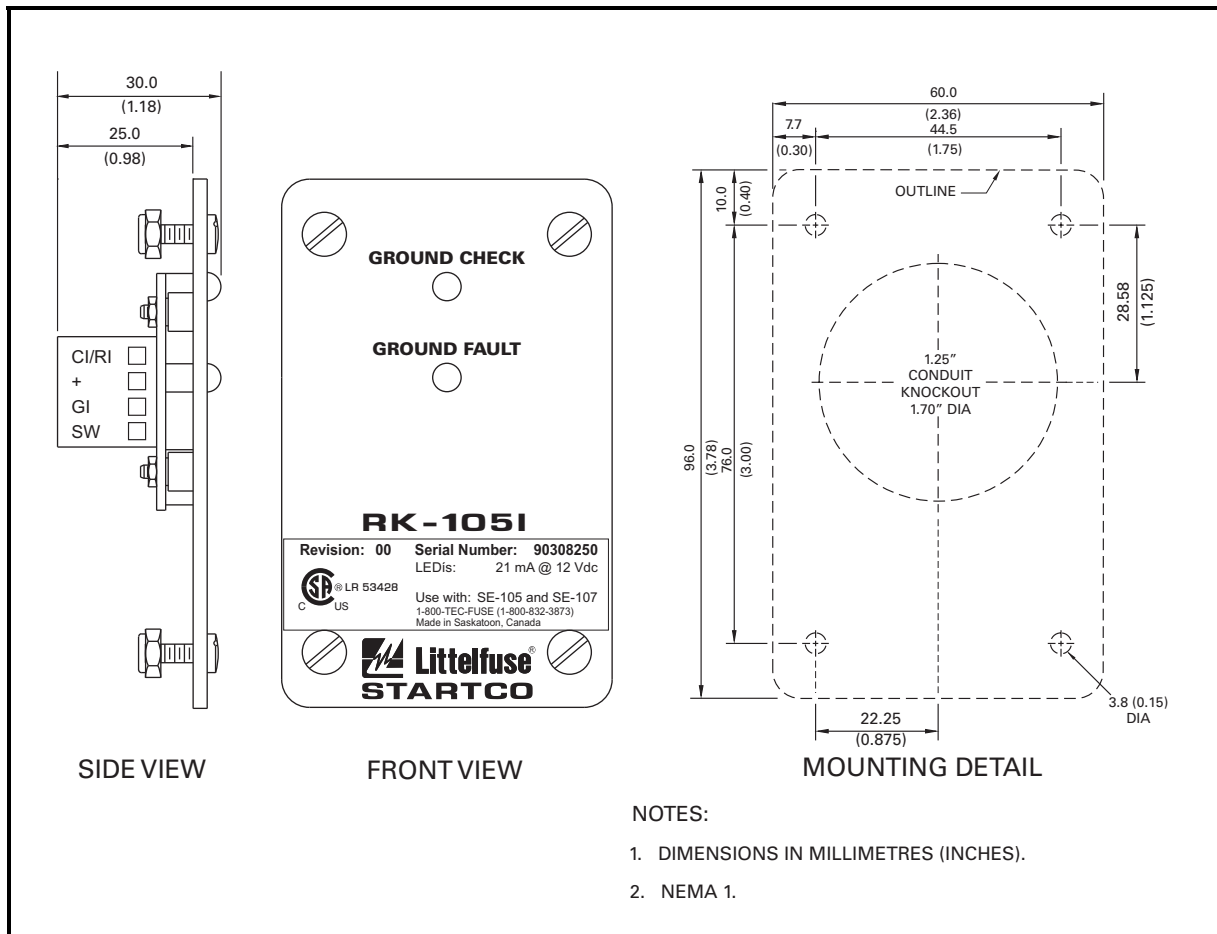

FIGURE 9. RK-105I Remote Indication Assembly.

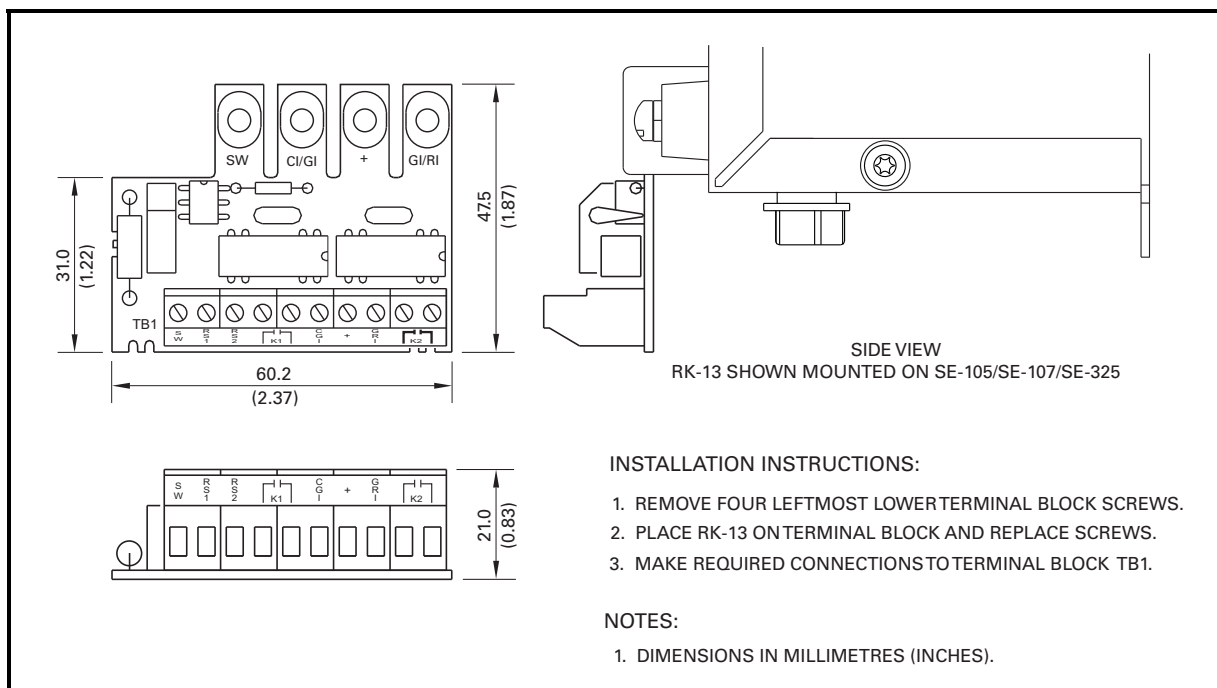

FIGURE 10. RK-13 Relay Interface Module.

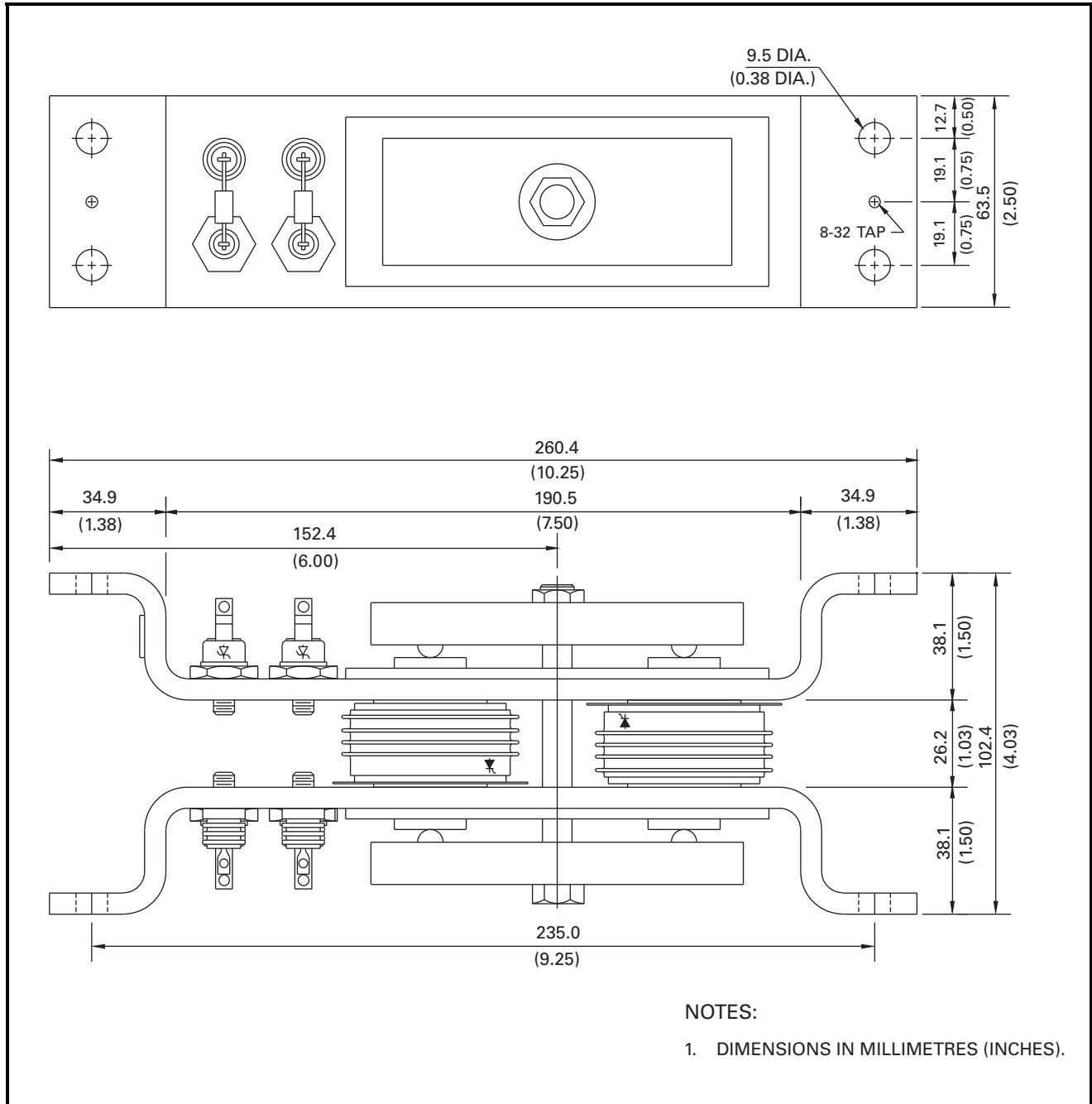

FIGURE 11. PPI-600V Parallel-Path Isolator.

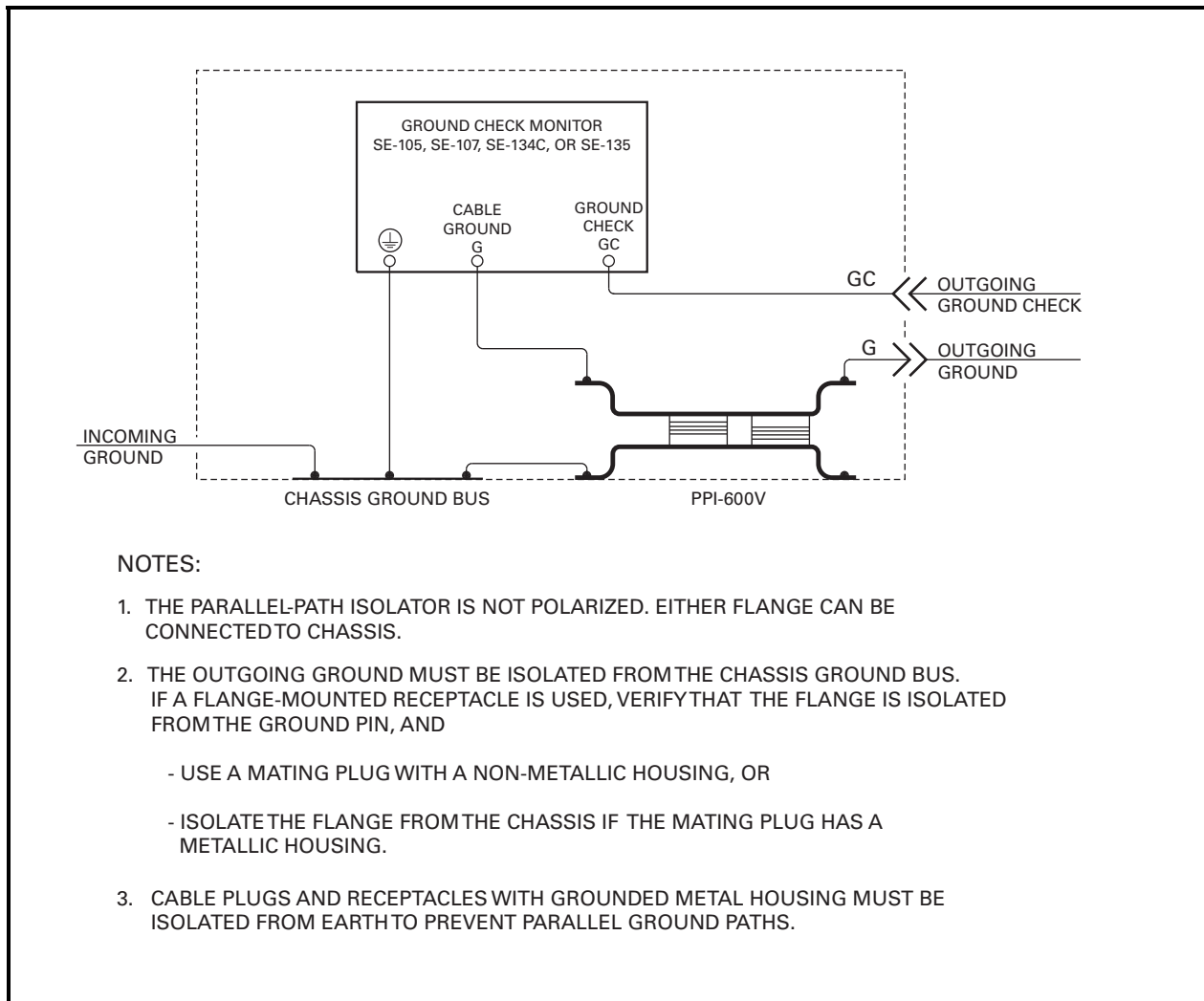

FIGURE 12. PPI-600V Typical Installation.

**5. TECHNICAL SPECIFICATIONS**

Supply:

ac ..... 10 VA, 120 or 240 Vac  
(+10, -45%), 50/60 Hz  
ac/dc ..... 5W, 120 Vdc (+40, -8%),  
5 VA, 120 Vac  
(+10, -29%), 47 to 440 Hz,

NOTE: Voltage between supply terminals (L1, L2) and ground terminal (G) must not exceed 300 Vac continuous or 1,250 Vac under transient conditions.

Dimensions:

Height ..... 150 mm (5.9")  
Width ..... 109 mm (4.3")  
Depth ..... 100 mm (4.0")

Shipping Weight ..... 1 kg (2.2 lb)

Environment:

Operating Temperature ..... -40 to 60°C  
Storage Temperature ..... -55 to 80°C  
Humidity ..... 85% Non-Condensing

Ground-Fault Circuit:

CT Ratio ..... 200:5  
CT Input Burden ..... 0.02 Ω  
Trip Level <sup>(1)</sup> ..... 0.5, 2.0, or 4.0 A  
Frequency Response ..... 25 to 110 Hz  
Trip Time ..... 0.1 to 2.0 s  
Thermal Withstand <sup>(1)</sup> ..... 200 A Continuous,  
2,500 A for 2 s  
Trip-Level Accuracy ..... +10, -20%  
CT Lead Resistance Limit <sup>(2)</sup>  
0.5 A Trip Level ..... 2 Ω  
2 A Trip Level ..... 5 Ω  
4 A Trip Level ..... 5 Ω  
Trip-Time Accuracy ..... 10%  
Operating Mode ..... Latching

<sup>(1)</sup> Currents referred to primary of CT200 for prospective ground-fault currents less than 4,000 A.  
<sup>(2)</sup> Typical maximum CT lead resistance to meet specified trip-level accuracy.

Ground-Check Circuit:

Open-Circuit Voltage ..... 12 Vdc  
Output Impedance ..... 240 Ω  
Nominal Loop Current ..... 25 mA  
Induced-ac Withstand ..... 25 Vac Continuous,  
120 Vac for 3 s  
Fuse Rating (F2) ..... 0.5 A, 250 Vac,  
Time Delay  
Fuse Part Number ..... Littelfuse 313.500 or  
Bussman MDA-1/2,  
MDL-1/2

Pull-in Filter ..... Chopper Rejection  
Pull-in Time ..... 1.5 s  
Trip Time ..... 0.2 s (GC open),  
0.5 s (GC to G short)  
Trip-Time Accuracy ..... +10, -30%  
GC-Loop Trip Resistance .. 40 ± 10 Ω  
Operating Mode ..... Non-Latching,  
Latching with Option L

Output Relay:

CSA/UL Contact Ratings... 1 mA to 4 A Resistive,  
240 Vac or 28 Vdc

Supplemental Contact Ratings:

Make/carry 0.2 s ..... 10 A  
Carry continuous ..... 4 A

Break:

dc ..... 20 W Resistive,  
10 W Inductive  
(L/R=0.04 s)

ac ..... 960 VA Resistive,  
700 VA Inductive  
(PF=0.4)

Subject to maximums of 4 A and 240 V (ac or dc)

Contact Configuration ..... N.O. (Form A)

Fuse Rating (F1) ..... 4.0 A, 250 Vac,  
Time Delay

Fuse Part Number ..... Littelfuse 313.004 or  
Bussman MSL-4

Operating Mode ..... UV (Undervoltage/Fail-  
Safe) or SH (Shunt  
Trip/Non-Fail-Safe)

Remote Indication:

+ ..... 12 Vdc  
GI/CI ..... Current Sink,  
560 Ω Internal

Optional RK-13 Module:

Contact Ratings ..... 100 mA, 120 Vac  
Contact Configuration ..... N.O. (Form A)  
Reset Input ..... 24 to 120 V (ac or dc),  
Isolated

PWB Conformal Coating ..... MIL-1-46058 qualified,  
UL QMJU2 recognized

Certification ..... CSA, Canada and USA



Australia



**6. ORDERING INFORMATION**

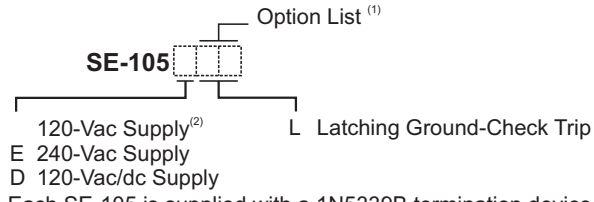

Each SE-105 is supplied with a 1N5339B termination device.  
 (1) List options required in order shown above.  
 (2) Standard, leave blank.

**Ground-Fault CT's:**

- CT200 .....56 mm (2.2") Window
- CT200L .....89 mm (3.5") Window

**Ground-Check Termination:**

- 1N5339B .....5-W Axial Lead Termination Device
- SE-TA6 .....50-W Termination Assembly
- SE-TA6-SM .....50-W Stud-Mount Termination Assembly
- SE-TA6ASF-WL .....12-W Small-Format Termination Assembly with Wire Leads

**Remote Indication and Reset:**

- RK-102.....Includes two LED pilot lights, a reset push button, and legend plates
- RK-105.....Indication-and-Reset Assembly
- RK-105I .....Indication Assembly
- RK-13.....Relay Interface Module

**Parallel-Path Isolator:**

- PPI-600V.....For system voltages up to 600 Vac

**7. WARRANTY**

The SE-105 Ground-Fault Ground-Check Monitor is warranted to be free from defects in material and workmanship for a period of five years from the date of purchase.

Littelfuse Startco will (at Littelfuse Startco's option) repair, replace, or refund the original purchase price of an SE-105 that is determined by Littelfuse Startco to be defective if it is returned to the factory, freight prepaid, within the warranty period. This warranty does not apply to repairs required as a result of misuse, negligence, an accident, improper installation, tampering, or insufficient care. Littelfuse Startco does not warrant products repaired or modified by non-Littelfuse Startco personnel.

Littelfuse Startco is not liable for contingent or consequential damages; for expenses sustained as a result of incorrect application, incorrect adjustment, or a malfunction; or for expenses resulting from the use of, or inability to use, the product.

## 8. GROUND-FAULT PERFORMANCE TEST

To meet the requirements of the National Electrical Code (NEC), as applicable, the overall ground-fault-protection system requires a performance test when first installed. A written record of the performance test is to be retained by those in charge of the electrical installation in order to make it available to the authority having jurisdiction. A test record form is provided for recording the date and the final results of the performance tests. The following ground-fault system tests are to be conducted by qualified personnel:

- a) Evaluate the interconnected system in accordance with the overall equipment manufacturer's detailed instructions.
- b) Verify proper location of the ground-fault current transformer. Ensure the cable or bus passes through the ground-fault current transformer window, and that the grounding conductors or shields are not encompassed by the ground-fault current transformer in such a way as to cause ground-fault current to be missed. These checks can be done visually with knowledge of the circuit involved. The connection of the current-transformer secondary to the SE-105 is not polarity sensitive.
- c) Verify that the system is correctly grounded and that alternate ground paths do not exist that bypass the current transformer. High-voltage testers and resistance bridges can be used to determine the existence of alternate ground paths.
- d) Verify proper reaction of the circuit-interrupting device in response to a simulated or controlled ground-fault current. To simulate ground-fault current, use CT-primary current injection. Fig. 13a shows a test circuit using an SE-400 Ground-Fault-Relay Test Unit. The SE-400 has a programmable output of 0.5 to 9.9 A for a duration of 0.1 to 9.9 seconds. Set the test current to 0.6, 2.3, or 4.6 A for SE-105 units set at 0.5, 2.0, or 4.0 A respectively. Fig. 13b shows a test circuit using an SE-100T Ground-Fault-Relay Tester. The SE-100T provides a test current of 0.65 or 2.75 A for testing 0.5- and 2.0-A trip levels. Inject the test current through the current-transformer window for at least 2.5 seconds. Verify that the circuit under test has reacted properly. Correct any problems and re-test until the proper reaction is verified.
- e) Record the date and the results of the test on the attached test-record form.

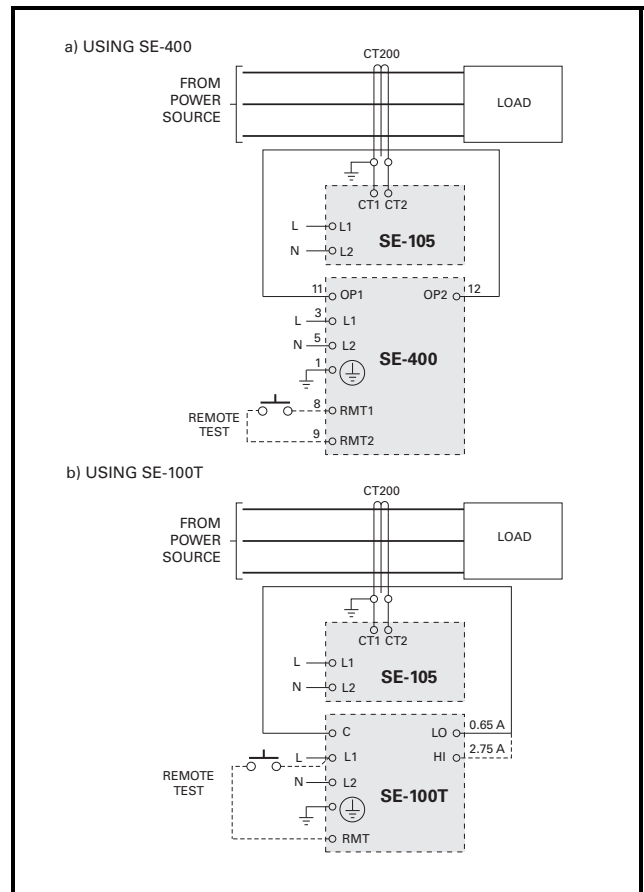

FIGURE 13. Ground-Fault-Test Circuits

