

SE-330, SE-330HV SERIES

Neutral-Grounding-Resistor Monitor



GROUND-FAULT PROTECTION RELAYS

Simplified Circuit Diagram

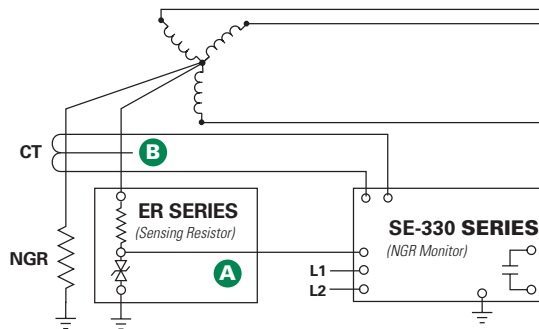

Ordering Information

CATALOG/SYSTEM NUMBER	COMMUNICATIONS	VOLTAGE
SE-330-00-00	RS-232	80-265 Vac/Vdc
SE-330-01-00	RS-232 & DeviceNet™	80-265 Vac/Vdc
SE-330-02-00	RS-232 & Profibus®	80-265 Vac/Vdc
SE-330-03-00	RS-232 & Ethernet	80-265 Vac/Vdc

NOTE: For 36-72 Vdc Control Power use part numbers SE-330-20-00, SE-330-21-00, SE-330-22-00 or SE-330-23-00 respectively. For applications over 35 kV, use SE-330HV. For Australian applications, see the SE-330AU on pg. 18.

ACCESSORIES	REQUIREMENT	PAGE
ER Series Sensing Resistor	Required	54
Current Transformer	Required	49
SE-IP65CVR-G	Optional	53
RK-332	Optional	53

Description

The SE-330 is an advanced ground-fault and grounding-resistor monitoring relay. It measures neutral current, neutral-to-ground voltage, and neutral-to-ground resistance. It provides continuous monitoring of the neutral-to-ground path to verify that the neutral-grounding resistor (NGR) is intact. This is of utmost importance—an open NGR renders current-sensing ground-fault protection inoperative and could result in a false belief that the system is functioning properly. The SE-330 can be used with low- and medium-voltage transformers and generators with low- or high-resistance grounding used in processing, manufacturing, chemical, pulp and paper, petroleum, and water-treatment facilities. For high-voltage applications, use the SE-330HV. For applications that require conformance to Australian standard AS/NZS 2081.3:2002, see the SE-330AU.

Resistor Monitoring

The SE-330 combines the measured values of resistance, current, and voltage to continuously determine that the NGR is intact. It is able to detect a resistor failure with or without a ground fault present. Sensing resistors are matched to the system voltage and are used to monitor NGRs on systems up to 72 kV.





Ground-Fault Monitoring

The SE-330 uses an application-appropriate current transformer to reliably detect ground-fault currents as small as 100 mA. DFT filtering ensures that false trips due to harmonic noise from adjustable-speed drives do not occur. Should the resistor open and a ground fault subsequently occur, the SE-330 will detect the fault through voltage measurement, while other current-only sensing relays would be ineffective.

Pulsing Ground-Fault Location

The SE-330 is capable of controlling a pulsing contactor, which is used to switch the NGR resistance in a pulsing-compatible NGR package. The resulting ground-fault current is distinguishable from charging currents and noise and will only appear upstream of the ground fault, making fault location fast and easy, even without isolating feeders or interrupting loads.

Accessories

- A**  **ER Series Sensing Resistor**
Required interface between the power system and the SE-330/SE-330HV. Eliminates hazardous voltage levels at the relay.
- B**  **EFCT Series Ground-Fault Current Transformer**
Sensitive ground-fault current detection (5 A primary).
-  **SE-CS30 Series Ground-Fault Current Transformer**
Sensitive ground-fault current detection (30 A primary).
-  **Other Current Transformer**
For low-resistance NGRs choose a CT primary approximately equal to the NGR rating.

Features & Benefits

FEATURES	IEEE #	BENEFITS
Continuous NGR Monitoring	3	Detects resistor failure within seconds, reduces transient-overvoltage risk, removes risk of ground-fault-detection failure
Ground-Fault Detection	50G/N, 51G/N, 59N	Main or backup protection to detect a ground fault anywhere on the monitored system
Adjustable Pickup (2-100%)		Select greatest sensitivity without false operation
Adjustable Time Delay (0.1-10 s)		Adjustable trip delay allows quick protection and system coordination
Universal CT Compatibility		Allows the use of a CT that gives required ground-fault settings
Output Contacts		Two Form C (Ground Fault and Resistor Fault), Two Form A (Trip/Pulse, Healthy)
Analog Output (4-20 mA)		Allows for connecting an optional PGA-0500 meter or control system
Pulsing Output		Control the operation of a pulsing ground-fault-location circuit
Data Logging		On-board 10-event recorder helps with system diagnostics
Harmonic Filtering (DFT)		Eliminate false trips due to harmonic noise from ASDs
Local Communications		RS-232 port to view measured values, log to a PC and check event records
Network Communications		Remotely view measured values and event records, reset trips, and cause a remote trip
Software		PC-interface software (SE-MON330) is included
Selectable Contact Operating Mode		Selectable fail-safe or non-fail-safe operating modes allows connection to shunt or undervoltage breaker coil or alarm circuit
Selectable Reset Mode		Selectable latching or auto-reset operation
Calibrate Push Button		Ensures resistor-failure sensitivity is correct
Unit-Healthy Output		Verifies SE-330 is operating correctly
Conformal Coating		Internal circuits are conformally coated to protect against corrosion and moisture

Typical Values

SYSTEM VOLTAGE (VOLTS)	NEUTRAL-GROUNDING RESISTOR		SENSING RESISTOR		GROUND-FAULT PICKUP LEVEL (AMPERES)	V _N PICKUP LEVEL (VOLTS)
	CURRENT (AMPERES)	RESISTANCE (OHMS)	MODEL	RESISTANCE (SWITCH S5 SETTING)		
480	5	55	ER-600VC	20 kΩ	2.5	170
600	5	69	ER-600VC	20 kΩ	2.5	200
2,400	5	277	ER-5KV	20 kΩ	2.5	800
4,160	5	480	ER-5KV	20 kΩ	3	1,700
7,200	10	416	ER-15KV	100 kΩ	2	170 x 5 = 850
14,400	15	554	ER-15KV	100 kΩ	3	340 x 5 = 1,700

DISCLAIMER: The above table is for illustrative purposes only. Actual values may differ based on a variety of individual system considerations, such as capacitive charging current and coordination study results.

Wiring Diagram

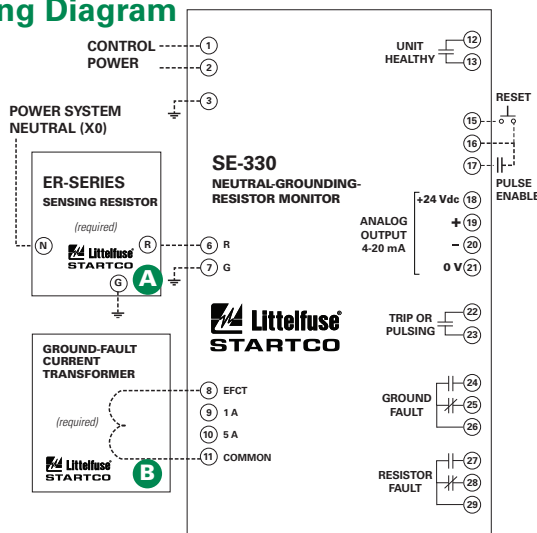

Specifications

IEEE Device Numbers

Ground fault (50G/N, 51G/N, 59N),
Checking Relay (3), Lockout Relay (86)

Input Voltage Dimensions

See ordering information
H 213 mm (8.4"); **W** 98 mm (3.9"); **D** 132 mm (5.2")

GF Trip-Level Settings

2-100% of CT-Primary Rating

GF Trip-Time Settings

0.1-10 s

V_n Trip-Level Settings

20-2,000 Vac (≤5 kV systems)
100-10,000 Vac (>5 kV systems)

Contact Operating Mode

Selectable fail-safe or non-fail-safe (K1)

Harmonic Filtering

Standard feature

Reset Button

Standard feature

Output Contacts

Two Form A and Two Form C

Pulsing Circuit

1.0-3.0 s in 0.2 s increments

Approvals

CSA certified to US and Canadian standards, CE

Communications

RS-232; DeviceNet™, Profibus®, Ethernet

Analog Output

4-20 mA, self or loop powered

Conformally Coated

Standard feature

Warranty

5 years

Mounting

Panel and Surface